



Prices effective as of  
March 6, 2005

# Industrial Products for Metalworking





3M aims to help you improve your profitability and build a competitive edge.

Among 3M's strong portfolio of industrial products, there are many which play an important role in metalworking. You may already be using some of them. We know, from experience, the issues you face and the type of practical problems you have to overcome.

This catalog contains our most popular standard stock\* products for metalworking. Many additional products are also available.

Combine this with 3M's leadership in many of the technologies you use and you have a resource of tremendous potential value — a business partner with the knowledge, the industry experience, and the commitment to help you make real improvements.

From incoming raw materials to the packaging of finished items, we can help you reduce costs and increase productivity.

It all adds up to a formidable business development resource — and it's all yours for the taking.

■ ***For advice or technical help call:***

**1-866-279-1288 ext. 8005**

**Fax: 1-877-369-2923**

# Table of Contents

## ■ Discs

3M™ Fibre Discs	4–6
3M™ Green Corps™ Flexible Grinding Wheels	7
3M™ Green Corps™ Depressed Center Wheels	7
3M™ Flap Discs	8
3M™ Roloc™ Discs	9–13
Scotch-Brite™ Roloc™ Discs	12
Scotch-Brite™ Roloc™ Bristle Discs	12
Scotch-Brite™ High Strength Discs	14
Scotch-Brite™ Surface Conditioning Discs	14–16
3M™ Stikit™ Discs	17–18
3M™ PSA Discs	17, 19

## ■ Belts

3M™ Portable Tool Belts	20
3M™ Backstand and Bench-Top Belts	21–23
Scotch-Brite™ Surface Conditioning Belts	24

## ■ Wheels

Scotch-Brite™ Unitized Wheels	25
Scotch-Brite™ Convolute Wheels	26
3M™ Flap Wheels	27
3M™ Green Corps™ Cut-Off Wheels	28

## ■ Specialty Products

Bench Area Products	29–31
Scotch-Brite™ Radial Bristle Brushes	29
Scotch-Brite™ Stars	29
Scotch-Brite™ Flap Brushes	30
Scotch-Brite™ Combi Wheel	30
Scotch-Brite™ Clean & Strip Discs	31
3M™ Cartridge Rolls	32–33
3M™ Evenrun Bands	34–35

## ■ Hand Sanding

3M™ Utility Cloth Sheets & Rolls	36
3M™ Paper Sheets	37
Scotch-Brite™ Hand Pads	38
Scotch-Brite™ Rolls	39

## ■ 3M™ Intro Kits

3M™ Intro Kits	40–41
----------------	-------

## ■ Adhesives & Tapes

Adhesive Selection Guide	45
Aerosol Adhesives	45
Scotch-Grip™ Adhesives	46
Structural Adhesives	47
3M™ EPX™ Applicators & Accessories	48
3M™ VHB™ Tapes	49
3M™ Protective Tapes	50–51
Masking Products	52–54
Box Sealing Tapes & Dispensers	55
Duct Tapes	55

## ■ Safety Products

3M™ Particulate Respirators	56–57
3M™ Full and Half Facepiece Respirators	58–59, 61
Filters and Retainers	60–61
3M™ Speedglas™ Welding Products	62
Hearing Protection	63–64
Sorbents	64
Eye Protection	65

## ■ Welding Products

Welding Products	66
------------------	----

## ■ Mattings

3M™ Mattings	67
--------------	----

## ■ Cleaners/Maintenance

Cleaners	68
Concrete Repair	68

## ■ Charts

Machine/Product Chart	42–43
Grade Comparison Chart	44

UPC Index	69–72
-----------	-------

# 3M™ Discs

Discs  
Fibre

	MILD STEEL	STAINLESS STEEL
<b>GOOD</b>	281C	501C
<b>BETTER</b>	501C	785C
<b>BEST</b>	988C	985C

LEGEND: ■ MILD STEEL ■ STAINLESS STEEL



159044

## 3M™ Fibre Discs

### 281C ■

(Aluminum Oxide – Fibre)

General purpose disc for weld removal, grinding and blending.

Dia x Ctr Hole	Grade	UPC	Min./Case	List Price
4½" x 7/8" Max RPM 13,300	24	051144-85959-7	25/100	0.98
	36	051144-85960-3	25/100	0.96
	50	051144-85961-0	25/100	0.90
	60	051144-85962-7	25/100	0.86
	80	051144-85963-4	25/100	0.80
5" x 7/8" Max RPM 12,000	24	051144-85966-5	25/100	0.98
	36	051144-85967-2	25/100	0.96
	50	051144-85968-9	25/100	0.90
	60	051144-85969-6	25/100	0.86
	80	051144-85970-2	25/100	0.80
7" x 7/8" Max RPM 8,600	24	051144-85973-3	25/100	1.34
	36	051144-85974-0	25/100	1.31
	50	051144-85975-7	25/100	1.22
	60	051144-85976-4	25/100	1.16
	80	051144-85977-1	25/100	1.09

### 501C ■ ■

(Alumina Zirconia – Fibre)

Versatile disc for use on a wide variety of metals.

Dia x Ctr Hole	Grade	UPC	Min./Case	List Price
4½" x 7/8" Max RPM 13,300	24	051111-50409-3	25/100	1.53
	36	051111-50413-0	25/100	1.51
	50	051111-50414-7	25/100	1.40
	60	051111-50415-4	25/100	1.34
	80	051111-50416-1	25/100	1.25
5" x 7/8" Max RPM 12,000	24	051111-50410-9	25/100	1.53
	36	051111-50412-3	25/100	1.51
	50	051111-50420-8	25/100	1.40
	60	051111-50421-5	25/100	1.34
	80	051111-50422-2	25/100	1.25
7" x 7/8" Max RPM 8,600	24	051111-50411-6	25/100	2.10
	36	051111-50426-0	25/100	2.05
	50	051111-50425-3	25/100	1.91
	60	051111-50427-7	25/100	1.82
	80	051111-50428-4	25/100	1.71
	100	051111-50429-1	25/100	1.71
120	051111-50430-7	25/100	1.71	

### 988C ■

(3M™ Cubitron™ Abrasive Grain – Fibre)

3M's best premium disc for long-lasting performance for mild steel grinding.

Dia x Ctr Hole	Grade	UPC	Min./Case	List Price
5" x 7/8" Max RPM 12,000	24	051111-55746-4	25/100	2.67
	36	051111-55743-3	25/100	2.62
	50	051111-55742-6	25/100	2.44
	60	051111-55741-9	25/100	2.33
	80	051111-55740-2	25/100	2.19
	P100	051111-55752-5	25/100	2.19
7" x 7/8" Max RPM 8,600	P120	051111-55751-8	25/100	2.19
	24	051111-55694-2	25/100	3.08
	36	051111-55965-9	25/100	3.02
	40	051111-55966-6	25/100	2.83
	50	051111-55967-3	25/100	2.83
	60	051111-55739-6	25/100	2.68
	80	051111-55968-0	25/100	2.52
	P100	051111-55969-7	25/100	2.52
	P120	051111-55970-3	25/100	2.52



51773

## 3M™ Fibre Discs (cont.)

### 785C

(3M™ Cubitron™ Abrasive Grain – Fibre)

785C is an excellent starting point for stainless steel. It includes a grinding aid for cooler running.

Dia x Ctr Hole	Grade	UPC	Min./Case	List Price
<b>4 1/2" x 7/8"</b> Max RPM 13,300	36	051144-80660-7	25/100	2.39
	50	051144-80661-4	25/100	2.23
	60	051144-80662-1	25/100	2.12
	80	051144-80663-8	25/100	1.97
	P120	051144-80665-2	25/100	1.97
<b>5" x 7/8"</b> Max RPM 12,000	24	051144-13931-6	25/100	2.15
	36	051144-13930-9	25/100	2.12
	50	051144-13928-6	25/100	1.97
	60	051144-56563-6	25/100	1.88
	80	051144-13926-2	25/100	1.75
<b>7" x 7/8"</b> Max RPM 8,600	P100	051144-80654-6	25/100	1.97
	P120	051144-80655-3	25/100	1.97
	24	051144-13937-8	25/100	2.44
	36	051144-13936-1	25/100	2.39
	50	051144-13934-7	25/100	2.22
	60	051144-13933-0	25/100	2.12
	80	051144-13932-3	25/100	1.99
	P100	051144-80656-0	25/100	2.25
	P120	051144-80657-7	25/100	2.25



179577

### 985C

(3M™ Cubitron™ Abrasive Grain – Fibre)

3M's most aggressive mineral makes 985C the best choice for a long-lasting, premium disc for stainless steel.

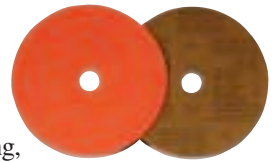

157186

Dia x Ctr Hole	Grade	UPC	Min./Case	List Price
<b>5" x 7/8"</b> Max RPM 12,000	36	051111-55767-9	25/100	2.69
	50	051111-55780-8	25/100	2.51
	60	051111-55776-1	25/100	2.40
	80	051111-55779-2	25/100	2.26
<b>7" x 7/8"</b> Max RPM 8,600	24	051111-55971-0	25/100	2.91
	36	051111-55972-7	25/100	2.85
	50	051111-55973-4	25/100	2.67
	60	051111-55974-1	25/100	2.53
	80	051111-55975-8	25/100	2.38



## Accessories — 3M™ Fibre Discs

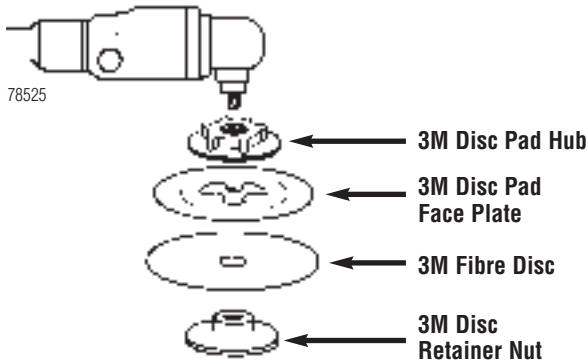

### Disc Pad Hub

Plastic hubs with  $\frac{3}{8}$ "-11 metal insert.  
Use with 3M™ disc pad face plates.



Dia	UPC	Min./Case	List Price
<b>2½"</b> Use with all size face plates	051144-45205-7	1/10	15.78
<b>4½"</b> Use with 7" face plates only	051144-45190-6	1/10	15.78
<b>2½"</b> Use with all size face plates, tool shaft length ½" or less	051144-88743-9	1/10	15.78

### Disc Pad Face Plates

Backup plates for fibre discs.  
3M™ disc pad face plates are color coded by density.



- Ribbed plates result in cooler running discs
- Use harder face plates for heavier stock removal applications

Dia	Hardness	UPC	Min./Case	List Price
<b>4½"</b> Smooth Max RPM 13,300	Medium – Gray	051144-13325-3	1/25	11.87
	Hard – Black	051144-14270-5	1/25	11.87
<b>5"</b> Ribbed Max RPM 12,000	Medium – Gray	051144-81734-4	1/25	15.14
	Hard – Black	051144-81733-7	1/25	15.14
	Extra Hard – Red	051144-81732-0	1/25	15.14
<b>7"</b> Ribbed Max RPM 8,600	Medium – Gray	051144-80516-7	1/25	20.82
	Hard – Black	051144-80515-0	1/25	20.82
	Extra Hard – Red	051144-80514-3	1/25	20.82

### Disc Retainer Nuts

For use with all 3M™ disc pad face plates, disc pads, and 3M™ disc pad hubs. Nuts have  $\frac{3}{8}$ "-11 threaded arbor hole in three depths to accommodate grinder shaft lengths.



Depth	UPC	Min./Case	List Price
$\frac{3}{8}$ "	051144-05622-4	1	3.28
$\frac{1}{2}$ "	051144-05621-7	1	3.28
$\frac{5}{8}$ "	051144-05620-0	1	3.28
$\frac{5}{16}$ "	051111-51047-6	1/10	6.75

### Disc Holder Adapter No. 9

These adapters will convert a grinder with M10-1.25, M10-1.5, or  $\frac{3}{8}$ "-24 external threaded shaft to a  $\frac{3}{8}$ "-11 external threaded shaft.



Thread Size	UPC	Min./Case	List Price
M10-1.25 INT	048011-22971-3	10	8.33
M10-1.50 INT	048011-22972-0	10	8.84
$\frac{3}{8}$ "-24 INT	048011-22970-6	10	8.84

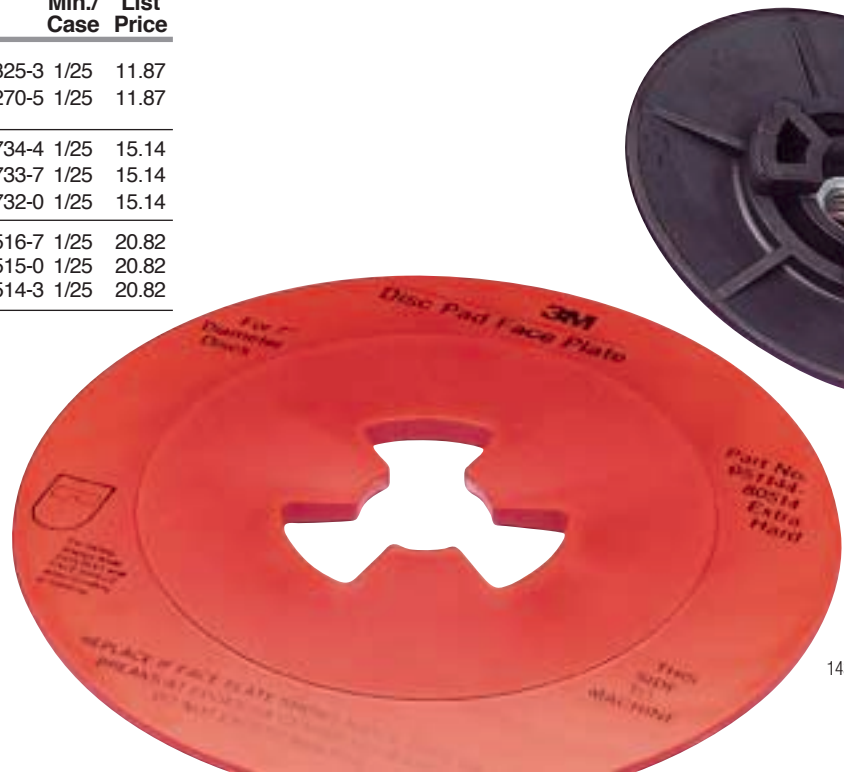

## Flexible Grinding Wheels

### 3M™ Green Corps™ Flexible Grinding Wheel

Bonded abrasive wheel designed for right angle tools. 3M™ Cubitron™ abrasive grain provides a fast cut and a smooth finish on a variety of workpieces, eliminating several process steps. Do not use on tools without guards.

Applications include:

- Weld grinding and blending
- Descaling
- Weld spatter removal



159110

Dia x Thk x AH	Grade	UPC	Min./Case	List Price
4½" x ⅛" x ⅞"	36	051111-50440-6	20/200	4.26
	46	051111-50442-0	20/200	4.26
	60	051111-50443-7	20/200	4.26
	80	051111-50444-4	20/200	4.26
7" x ⅛" x ⅞"	36	051111-50445-1	20/100	7.07
	46	051111-50446-8	20/100	7.07
	60	051111-50447-5	20/100	7.07
	80	051111-50448-2	20/100	7.07

### 3M™ Green Corps™ Flexible Grinding Wheel (Quick Change)

Threaded for easy disc changes. No additional backup pad required. Do not use on tools without guards.

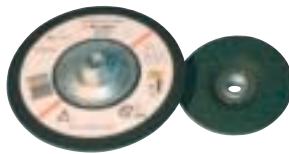

148177

Dia x Thk x AH	Grade	UPC	Min./Case	List Price
4½" x ⅛" x ⅝"-11	36	051111-51164-0	10/100	4.81
	46	051111-51161-9	10/100	4.81
	60	051111-51160-2	10/100	4.81
7" x ⅛" x ⅝"-11	36	051111-51163-3	10/40	7.74
	46	051111-51162-6	10/40	7.74
	60	051111-51159-6	10/40	7.74

## Accessories

### Flexible Grinding Wheel Backup Pad

Backup pad is required for safe operation of Flexible Grinding Wheels with ⅝" center hole.



159101

Dia x AH	UPC	Min./Case	List Price
3⅝" x ⅞"	051111-51046-9	5/100	1.50
4⅝" x ⅞"	051111-51045-2	5/100	2.10

## Depressed Center Wheel

### 3M™ Green Corps™ Depressed Center Wheel

(Type 27—Quick Change)  
(3M™ Cubitron™ Abrasive Grain)  
Bonded abrasive wheel provides a high rate of stock removal and long life.

Do not use on tools without guards.

Applications include:

- Weld grinding on mild steel, cast iron and stainless steel
- Flash, gate and riser removal

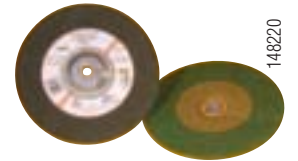

148820

Dia x Thk x AH	Grade	UPC	Min./Case	List Price
4½" x ¼" x ⅞"	24	051111-55991-8	10/60	5.27
	36	051111-55992-5	10/60	5.27
4½" x ¼" x ⅝"-11	24	051111-55960-4	10/60	5.81
	36	051111-55961-1	10/60	5.81
7" x ¼" x ⅞"	24	051111-55989-5	10/20	8.62
	36	051111-55990-1	10/20	8.62
7" x ¼" x ⅝"-11	24	051111-55958-1	10/20	9.30
	36	051111-55959-8	10/20	9.30

## Accessories

### Flap Disc/Grinding Wheel Adapter Nut

Adapter nut used for securing 4½" diameter flap discs or 4½" and 7" flexible grinding wheels to right angle tool with a ⅝"-11 threaded shaft.



156149

Thread Size	UPC	Min./Case	List Price
⅝"-11	051144-88765-1	1 Pair/5 Pair	18.52/Pair

162933

# 3M™ Flap Discs

## 563D

**Best Choice: Mild Steel**

(Alumina Zirconia – Type 29)  
Fast cutting disc with exceptionally long life. Works great on a wide variety of metals.



51702

Dia x Ctr Hole	Grade	UPC	Qty./Case	List Price
4 1/2" x 7/8" Max RPM 13,300	P36	051111-50467-3	10	6.00
	P40	051111-50468-0	10	6.00
	P60	051111-50469-7	10	6.00
	P80	051111-50470-3	10	6.00
	P120	051111-50471-0	10	6.00
7" x 7/8" Max RPM 8,600	P36	051111-50472-7	5	11.53
	P40	051111-50473-4	5	11.53
	P60	051111-50474-1	5	11.53
	P80	051111-50475-8	5	11.53

## 563D Quick Change

**Best Choice: Mild Steel**

(Alumina Zirconia – Type 29)  
• Mild steel applications.  
Threaded for easy disc changes.



159103

Dia x Ctr Hole	Grade	UPC	Qty./Case	List Price
4 1/2" x 5/8"-11 Max RPM 13,300	P36	051111-50769-8	10	8.27
	P40	051111-50770-4	10	8.27
	P60	051111-50771-1	10	8.27
	P80	051111-50772-8	10	8.27
7" x 5/8"-11 Max RPM 8,600	P36	051111-50774-2	5	14.36
	P40	051111-50775-9	5	14.36
	P60	051111-50776-6	5	14.36
	P80	051111-50777-3	5	14.36

May use Disc Holder Adapter No. 9 on Page 6.

## 747D

**Best Choice: Stainless Steel**

(Ceramic Aluminum Oxide – Type 27)  
Premium ceramic mineral provides exceptional cut and life on the hardest metals.



84696

Dia x Ctr Hole	Grade	UPC	Qty./Case	List Price
4 1/2" x 7/8" Max RPM 13,300	36	051111-49613-8	10	6.00
	50	051111-49614-5	10	6.00
	60	051111-49615-2	10	6.00
	80	051111-49616-9	10	6.00
	P120	051111-49617-6	10	6.00
7" x 7/8" Max RPM 8,600	36	051111-49608-4	5	11.53
	50	051111-49609-1	5	11.53
	60	051111-49610-7	5	11.53
	80	051111-49611-4	5	11.53



51700

## Accessories

### Flap Disc/Grinding Wheel Adapter Nut

Adapter nut used for securing 4 1/2" diameter flap discs or 4 1/2" and 7" flexible grinding wheels to right-angle tool with a 5/8"-11 threaded shaft.



158149

Thread Size	UPC	Min./Case	List Price
5/8"-11	051144-88765-1	1 Pair/5 Pair	18.52/Pair

### Flap Disc Holder

Backup plate for 7" diameter type 27 flap discs.



158318

Dia x Thread Size	UPC	Qty./Case	List Price
4" x 5/8"-11	051144-88769-9	1	60.04



# 3M™ Roloc™ Discs

Provide a fast, efficient method for grinding, blending, leveling and finishing on all types of metal. They lock securely in place with just a half twist...another half twist and they're off. Each disc is color coded by grade. (This does not include Roloc™ TSM products.)



## 3M™ Roloc™ Disc Button Color/Grade Chart

24/Black	80/Yellow	180/Brown
36/Brown	100/Blue	240/Green
50/Green	120/White	
60/Orange	150/Black	

## 3M™ Roloc™ Disc Selection Chart





	MILD STEEL		STAINLESS STEEL	
	Roloc Cloth	Roloc Fibre	Roloc Cloth	Roloc Fibre
<b>BETTER</b>	361F	501C	777F	785C
<b>BEST</b>	963G	983C/988C	977F	985C

LEGEND:   MILD STEEL   STAINLESS STEEL

## 3M™ Roloc™ Disc 361F

(Aluminum Oxide – YF wt. Cloth)

General purpose grinding, blending and finishing on all metals.

Dia	Grade	UPC	Min./Case	List Price	
<b>Roloc TR (Plastic Button)</b>  78458					
1"	36	051144-11412-2	50/500	0.33	
	50	051144-11411-5	50/500	0.33	
	Roloc TR	60	051144-11417-7	50/500	0.32
	Max RPM	80	051144-11416-0	50/500	0.32
	30,000	P100	051144-11415-3	50/500	0.32
		P120	051144-11414-6	50/500	0.32
1½"	36	051144-22396-1	50/500	0.41	
	50	051144-11137-4	50/500	0.40	
	Roloc TR	60	051144-22397-8	50/500	0.38
	Max RPM	80	051144-22407-4	50/500	0.38
	30,000	P100	051144-22408-1	50/500	0.38
		P120	051144-22409-8	50/500	0.38
2"	24	051144-11000-1	50/200	0.68	
	36	051144-22398-5	50/200	0.64	
	50	051144-22399-2	50/200	0.61	
	60	051144-22400-5	50/200	0.57	
	Roloc TR	80	051144-22401-2	50/200	0.56
	Max RPM	P100	051144-22402-9	50/200	0.56
	25,000	P120	051144-22403-6	50/200	0.56
		P150	051144-14559-1	50/200	0.56
		P180	051144-13873-9	50/200	0.56
		P240	051144-11419-1	50/200	0.56
<b>Roloc TR (Plastic Button)</b>  78458					
3"	24	051144-22392-3	50/200	0.89	
	36	051144-22393-0	50/200	0.83	
	50	051144-22394-7	50/200	0.76	
	60	051144-22395-4	50/200	0.73	
	Roloc TR	80	051144-22404-3	50/200	0.73
	Max RPM	P100	051144-22405-0	50/200	0.70
	20,000	P120	051144-22406-7	50/200	0.70
		P150	051144-82244-7	50/200	0.70
		P240	051144-11418-4	50/200	0.70
		<b>Roloc TSM (Metal Button)</b>  221758			
1½"	36	051111-49932-0	50/500	0.41	
	Roloc TSM	60	051111-49933-7	50/500	0.38
	Max RPM	80	051111-49934-4	50/500	0.38
	30,000	P100	051111-51039-1	50/500	0.38
		36	051111-49936-8	50/200	0.64
2"	60	051111-49937-5	50/200	0.57	
	Roloc TSM	80	051111-49938-2	50/200	0.56
	Max RPM	P100	051111-51034-6	50/200	0.56
	25,000	P120	051111-49939-9	50/200	0.56
		3"	36	051111-51033-9	50/200
Roloc TSM	60		051111-49940-5	50/200	0.73
Max RPM	80		051111-49941-2	50/200	0.73
20,000	P100		051111-49942-9	50/200	0.70
	P120		051111-49943-6	50/200	0.70
<b>Roloc TP (Plastic Button)</b>  78467					
2"	36	051144-76798-4	50/200	0.64	
	50	051144-76802-8	50/200	0.61	
	Roloc TP	60	051144-76806-6	50/200	0.57
	Max RPM	80	051144-76810-3	50/200	0.56
	25,000	P100	051144-77115-8	50/200	0.56
		P120	051144-76778-6	50/200	0.56
3"	36	051144-76799-1	50/200	0.83	
	Roloc TP	50	051144-76803-5	50/200	0.76
	Max RPM	60	051144-76807-3	50/200	0.73
	20,000	80	051144-76811-0	50/200	0.73
		P100	051144-77116-5	50/200	0.70
	<b>Roloc TR (Plastic Button)</b>  78458				
4"	36	051144-76429-7	25/100	1.19	
	Max RPM	60	051144-11421-4	25/100	1.08
	12,000	80	051144-11420-7	25/100	1.05

### 3M™ Roloc™ Discs (cont.)

**3M™ Roloc™ Disc 461F**  
(Silicon Carbide – YF wt. Cloth)  
Ideal for grinding glass, titanium,  
and non-ferrous metals.



51704

Dia	Grade	UPC	Min./Case	List Price
<b>Roloc TR (Plastic Button)</b> 78458				
<b>2"</b>	P60	051144-12956-0	50/200	0.72
	Max RPM 25,000	P80	051144-12954-6	50/200
<b>3"</b>	P60	051144-12957-7	50/200	0.91
	Max RPM 20,000	P80	051144-12955-3	50/200

**3M™ Roloc™ Discs 777F**  
(3M™ Cubitron™ Abrasive Grain)  
• Cloth backing  
• Grinding aid



78932

Dia	Grade	UPC	Min./Case	List Price	
<b>Roloc TR (Plastic Button)</b> 78458					
<b>1"</b>	36	051144-76622-2	50/500	0.37	
	50	051144-76623-9	50/500	0.37	
	60	051144-76624-6	50/500	0.35	
	80	051144-76625-3	50/500	0.35	
	P120	051144-80510-5	50/500	0.35	
<b>1 1/2"</b>	36	051144-76626-0	50/500	0.45	
	50	051144-76627-7	50/500	0.44	
	60	051144-76628-4	50/500	0.41	
	80	051144-14660-4	50/500	0.41	
	P120	051144-80511-2	50/500	0.41	
<b>2"</b>	36	051144-76629-1	50/200	0.70	
	50	051144-76630-7	50/200	0.67	
	60	051144-76433-4	50/200	0.62	
	80	051144-14661-1	50/200	0.61	
	P100	051144-80508-2	50/200	0.61	
<b>3"</b>	P120	051144-80512-9	50/200	0.61	
	36	051144-76631-4	50/200	0.91	
	50	051144-76632-1	50/200	0.84	
	60	051144-76633-8	50/200	0.80	
	80	051144-76634-5	50/200	0.80	
<b>Roloc TS (Plastic Button)</b> 78469	P100	051144-80509-9	50/200	0.76	
	P120	051144-80513-6	50/200	0.76	
	<b>2"</b>	36	051144-76742-7	50/200	0.70
		50	051144-76746-5	50/200	0.67
		60	051144-76750-2	50/200	0.62
80		051144-76754-0	50/200	0.61	
<b>3"</b>	36	051144-76743-4	50/200	0.91	
	60	051144-76751-9	50/200	0.80	
	80	051144-76755-7	50/200	0.80	
<b>Roloc TSM (Metal Button)</b> 221758					
<b>2"</b>	36	051111-49949-8	50/200	0.70	
	60	051111-50253-2	50/200	0.62	
	80	051111-50254-9	50/200	0.61	



**3M™ Roloc™ Discs 963G**  
(3M™ Cubitron™ Abrasive Grain)  
• Cloth backing



Dia	Grade	UPC	Min./Case	List Price
<b>Roloc TR (Plastic Button)</b> 78458				
<b>1"</b>	36	051144-11423-8	50/500	0.37
	60	051144-11428-3	50/500	0.35
	80	051144-11427-6	50/500	0.35
	120	051144-11425-2	50/500	0.35
	<b>1 1/2"</b>	36	051144-11450-4	50/500
50		051144-11449-8	50/500	0.44
60		051144-11448-1	50/500	0.41
80		051144-11455-9	50/500	0.41
120		051144-11453-5	50/500	0.41
<b>2"</b>	24	051144-11113-8	50/200	0.75
	36	051144-11112-1	50/200	0.70
	40	051144-76436-5	50/200	0.68
	50	051144-11111-4	50/200	0.67
	60	051144-11110-7	50/200	0.62
	80	051144-11109-1	50/200	0.61
	100	051144-11107-7	50/200	0.61
	120	051144-11106-0	50/200	0.61
<b>3"</b>	24	051144-11108-4	50/200	0.97
	36	051144-11105-3	50/200	0.91
	50	051144-11104-6	50/200	0.84
	60	051144-11103-9	50/200	0.80
	80	051144-11102-2	50/200	0.80
	100	051144-11101-5	50/200	0.76
	120	051144-11100-8	50/200	0.76

**3M™ Roloc™ Discs 977F**  
(3M™ Cubitron™ Abrasive Grain)  
• Grinding aid



Dia	Grade	UPC	Min./Case	List Price
<b>Roloc TR (Plastic Button)</b> 78458				
<b>2"</b>	36	051144-83587-4	50/200	0.80
	60	051144-83588-1	50/200	0.72
	Max RPM 25,000	80	051144-83589-8	50/200
<b>3"</b>	60	051144-83591-1	50/200	0.92
	Max RPM 20,000	80	051144-83592-8	50/200

# 3M™ Roloc™ Fibre Discs



## 3M™ Roloc™ Fibre Disc 501C

(Aluminum Zirconia – Fibre)

- Versatile disc for use on a wide variety of metals.



148181

Dia	Grade	UPC	Min./Case	List Price
<b>Roloc TR (Plastic Button)</b>  78458				
<b>2"</b> Max RPM 25,000	50	051111-50748-3	50/200	0.66
	60	051111-50749-0	50/200	0.63
	80	051111-50750-6	50/200	0.59
<b>3"</b> Max RPM 20,000	36	051111-50743-8	50/200	0.87
	50	051111-50744-5	50/200	0.82
	60	051111-50745-2	50/200	0.78
<b>Roloc TSM (Metal Button)</b>  221758				
<b>2"</b> Max RPM 25,000	36	051111-50755-1	50/200	0.70
	50	051111-50756-8	50/200	0.66
	60	051111-50757-5	50/200	0.63
<b>3"</b> Max RPM 20,000	80	051111-50758-2	50/200	0.59
	36	051111-50751-3	50/200	0.87
	50	051111-50752-0	50/200	0.82
	60	051111-50753-7	50/200	0.78
	80	051111-50754-4	50/200	0.74



95305

## 3M™ Roloc™ Fibre Discs 983C/988C

(3M™ Cubitron™ Abrasive Grain)

- Fast cutting
- Long life

Dia	Grade	UPC	Min./Case	List Price
<b>Roloc TR (Plastic Button)</b>  78458				
<b>2"</b> Max RPM 25,000	36	051144-22352-7	50/200	1.15
	60	051144-22353-4	50/200	1.03
	80	051144-22354-1	50/200	0.97
<b>3"</b> Max RPM 20,000	36	051144-22349-7	50/200	1.43
	50	051144-85890-3	50/200	1.34
	60	051144-22350-3	50/200	1.29
	80	051144-22351-0	50/200	1.22
<b>4"</b> Max RPM 12,000	36	051111-55753-2	25/100	1.49
	50	051111-55754-9	25/100	1.42
	60	051111-55755-6	25/100	1.35
	80	051111-55756-3	25/100	1.28

## 3M™ Roloc™ Fibre Disc 785C

(3M™ Cubitron™ Abrasive Grain – Fibre)

785C is an excellent starting point for stainless steel. It includes a grinding aid for cooler running.



196943

Dia	Grade	UPC	Min./Case	List Price
<b>Roloc TR (Plastic Button)</b>  78458				
<b>3"</b> Max RPM 20,000	36	051144-85883-5	25/100	1.56
	50	051144-85884-2	25/100	1.46
	60	051144-85885-9	25/100	1.41
	80	051144-85886-6	25/100	1.33
<b>4"</b> Max RPM 12,000	36	051144-83690-1	25/100	2.04
	50	051144-83691-8	25/100	1.93
	60	051144-83692-5	25/100	1.85
	80	051144-83693-2	25/100	1.76
	P100	051144-83694-9	25/100	1.76
	P120	051144-83695-6	25/100	1.76



14494

Roloc™ Accessories are on Page 13.

## 3M™ Roloc™ Discs (cont.)

### Scotch-Brite™ Roloc™ Discs

Premium Scotch-Brite™ surface conditioning non-woven web provides a burr-free decorative finish. Removes grind marks, rust and coatings.





159116

A VFN – Blue

A MED – Maroon

A CRS – Brown

Dia	Grade	UPC	Min./Case	List Price	
<b>Roloc TR (Plastic Button)</b>  78458					
1 1/2"	ACRS	048011-08764-1	50/200	0.61	
	Max RPM 30,000	AMED	048011-08765-8	50/200	0.61
		AVFN	048011-08766-5	50/200	0.61
2"	ACRS	048011-05528-2	50/200	0.89	
	Max RPM 25,000	AMED	048011-05527-5	50/200	0.89
		AVFN	048011-05523-7	50/200	0.89
3"	ACRS	048011-05532-9	25/100	1.68	
	Max RPM 18,000	AMED	048011-05531-2	25/100	1.68
		AVFN	048011-05530-5	25/100	1.68
<b>Roloc TSM (Metal Button)</b>  221758					
1 1/2"	ACRS	048011-25775-4	50/200	0.61	
	Max RPM 30,000	AMED	048011-25774-7	50/200	0.61
		AVFN	048011-25773-0	50/200	0.61
2"	ACRS	048011-25765-5	50/200	0.89	
	Max RPM 25,000	AMED	048011-25764-8	50/200	0.89
		AVFN	048011-25770-9	50/200	0.89
3"	ACRS	048011-25767-9	25/100	1.68	
	Max RPM 18,000	AMED	048011-25766-2	25/100	1.68
		AVFN	048011-25780-8	25/100	1.68
<b>Roloc TP (Plastic Button)</b>  78467					
2"	ACRS	048011-13237-2	50/200	0.89	
	Max RPM 25,000	AMED	048011-13238-9	50/200	0.89
		AVFN	048011-13239-6	50/200	0.89
3"	ACRS	048011-13241-9	25/100	1.68	
	Max RPM 18,000	AMED	048011-13242-6	10/100	1.68



58804

### Scotch-Brite™ Bristle Discs

These discs efficiently clean and strip many substances from metal surfaces without damaging the work piece. An operator quickly and easily achieves a quality, consistent finish with light pressure.

Grade: 50 – Green

80 – Yellow

120 – White

Dia	Grade	UPC	Min./Case	List Price
2"	50	048011-18730-3	10/40	6.00
	Roloc TR 80	048011-18732-7	10/40	6.00
	Max RPM 25,000 120	048011-18733-4	10/40	6.00
3"	50	048011-18734-1	10/40	9.25
	Roloc TR 80	048011-18736-5	10/40	9.25
	Max RPM 15,000 120	048011-18737-2	10/40	9.25



159116

Roloc™ Accessories are on Page 13.

# Accessories

## 3M™ Roloc™ TR Disc Pads

Rubber backup pads are available in different diameters and degrees of hardness for various grinding applications. Pads are internally threaded to receive any standard 1/4"-20 thread shaft.

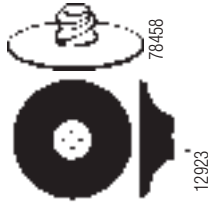

Dia	Hardness	UPC	Qty./Case	List Price
<b>1/4"-20 thread shaft</b>				
1" Roloc TR Max RPM 30,000	Medium	051144-45101-2	5	9.95
	Hard	051144-45100-5	5	11.36
1 1/2" Roloc TR Max RPM 30,000	Medium	051144-45099-2	5	11.36
	Hard	051144-45100-5	5	11.36
2" Roloc TR Max RPM 25,000	Medium	051144-45095-4	5	12.09
	Hard	051144-45096-1	5	12.09
3" Roloc TR Med Max RPM 18,000 Hard Max RPM 20,000	Medium	051144-45092-3	5	14.74
	Hard	051144-45091-6	5	14.74
4" Roloc TR Med Max RPM 12,000	Medium	051144-45179-1	5	16.63
	Hard	051144-45179-1	5	16.63
<b>5/8"-11 thread shaft</b>				
4" Roloc TR Med Max RPM 12,000	Medium	051144-83242-2	5	16.63
	Hard	051144-83489-1	5	16.63

## 3M™ Roloc™ TSM Disc Pads

For use with 3M™ Roloc™ TSM discs and "screw on" abrasive discs.



Dia	Hardness	UPC	Qty./Case	List Price
1 1/2" Roloc TSM Max RPM 30,000	Medium	051144-77729-7	5	11.36
	Hard	051144-77728-0	5	11.36
2" Roloc TSM Max RPM 25,000	Medium	051144-14211-8	5	12.09
	Hard	051144-14212-5	5	12.09
3" Roloc TSM Med Max RPM 18,000 Hard Max RPM 20,000	Medium	051144-14215-6	5	14.74
	Hard	051144-14216-3	5	14.74

## 3M™ Roloc™ TP Disc Pads

For use with 3M™ Roloc™ TP discs and with press on type abrasive discs.

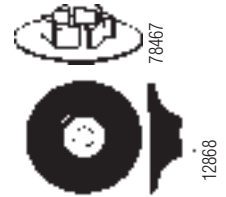

Dia	Hardness	UPC	Qty./Case	List Price
2" Roloc TP Max RPM 25,000	Medium	051144-14197-5	5	12.09
	Hard	051144-14198-2	5	12.09
3" Roloc TP Med Max RPM 18,000 Hard Max RPM 20,000	Medium	051144-14201-9	5	14.74
	Hard	051144-14202-6	5	14.74

## 1/4" Threaded Shaft

Needed with all 3M™ Roloc™ disc pads.

Size	UPC	Min./Case	List Price
1/4" x 1/4" x 20 Thread	051144-45102-9	1/50	2.04

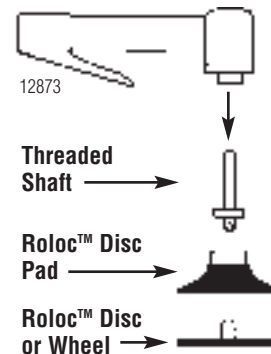

## Optimum Tool Speeds (RPM's) To Maximize 3M™ Roloc™ Coated Abrasive Disc Cut Rates and Life

### Material Type

Disc Size	Stainless	Aluminum	Steel	Titanium
1 1/2"	20,000 RPM	20,000 RPM	30,000 RPM	9,000 RPM
2"	15,000 RPM	15,000 RPM	20,000 RPM	7,000 RPM
3"	10,000 RPM	10,000 RPM	15,000 RPM	4,500 RPM
4"	8,000 RPM	9,000 RPM	9,000 RPM	3,000 RPM

# Scotch-Brite™ Surface Conditioning Discs

## Scotch-Brite™ Clean & Strip Discs

(Silicon Carbide – Extra Coarse)

Tough open web, ideal for weld cleaning and removing paint and coatings. Faster and safer than wire brushes.

Dia x Ctr Hole	Grade	UPC	Qty./Case	List Price
<b>4" x 1/2"</b> Max RPM 6,000	SXCS	048011-00941-4	25	6.60
<b>6" x 1/2"</b> Max RPM 4,000	SXCS	048011-00948-3	15	11.00
<b>8" x 1/2"</b> Max RPM 3,000	SXCS	048011-00957-5	15	17.16

Use with Mandrel 934



51717

## Scotch-Brite™ High Strength Discs

(Aluminum Oxide)

Very conformable discs, ideal for light deburring, cleaning and finishing.

Dia x Ctr Hole	Grade	UPC	Min./Case	List Price
<b>6" x 1/4"</b> Use with Mandrel 933 Max RPM 4,000	A VFN	048011-27748-6	10/40	1.96
	A VFN	048011-00666-6	100	1.96
<b>6" x 1/2"</b> Use with Mandrel 934 Max RPM 4,000	A MED	048011-27745-5	10/40	3.88
	A MED	048011-04188-9	100	3.88
	A VFN	048011-27747-9	10/40	1.96
	A VFN	048011-00665-9	100	1.96
<b>8" x 1/2"</b> Use with Mandrel 934 Max RPM 3,000	A MED	048011-27746-2	10/20	6.06
	A MED	048011-03992-3	50	6.06
	A VFN	048011-27749-3	10/20	3.05
	A VFN	048011-00672-7	50	3.05



51718

## Accessories

### Mandrels

Furnished complete with washers to fit available disc sizes.



**Mandrel No. 933**  
1/4" Shank  
1/4" Shaft Dia.

**Mandrel No. 934**  
1/4" Shank  
1/2" Shaft Dia.

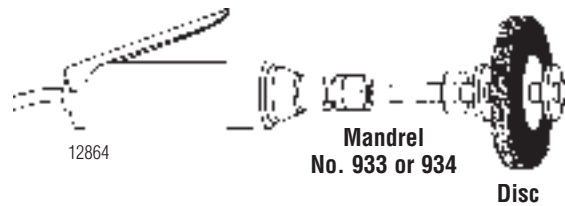

Length x Shank x Washer Dia	Catalog No.	UPC	Qty./Case	List Price
<b>2" x 1/4" x 1"</b>	933	048011-13968-5	5	6.42
<b>3 1/16" x 1/4" x 2 1/2"</b>	934	048011-04021-9	1	23.22

# Scotch-Brite™ Surface Conditioning Discs (cont.)

## Scotch-Brite™ Surface Conditioning Discs (Hook-and-Loop)

(Aluminum Oxide)

Scotch-Brite™ Surface Conditioning discs are best for finishing, cleaning, and light deburring on flat metal surfaces. Attach and remove easily to 3M™ Hook-and-Loop backup pads.

Used with the following hand tools:

- Right angle                             A VFN – Blue
- Random orbital                        A MED – Maroon
- A CRS – Brown

Dia	Grade	UPC	Min./Case	List Price
<b>2"</b> Max RPM 23,000	ACRS	048011-07458-0	50/200	0.81
	A MED	048011-07459-7	50/200	0.71
	AVFN	048011-04276-3	50/200	0.71
<b>3"</b> Max RPM 20,000	ACRS	048011-04120-9	25/100	1.58
	A MED	048011-04124-7	25/100	1.38
	AVFN	048011-04277-0	25/100	1.38
<b>4½"</b> Max RPM 13,000	ACRS	048011-27671-7	10	2.34
	ACRS	048011-14101-5	50	2.34
	A MED	048011-27672-4	10	2.05
	A MED	048011-14100-8	50	2.05
	AVFN	048011-27673-1	10	2.05
<b>5"</b> Max RPM 10,000	AVFN	048011-14099-5	50	2.05
	ACRS	048011-27674-8	10	2.79
	ACRS	048011-00750-2	50	2.79
	A MED	048011-27675-5	10	2.45
	A MED	048011-00643-7	50	2.45
<b>7"</b> Max RPM 6,000	AVFN	048011-27676-2	10	2.45
	AVFN	048011-04303-6	50	2.45
	ACRS	048011-27677-9	10	4.81
	ACRS	048011-00751-9	25	4.81
	A MED	048011-27678-6	10	4.22
	A MED	048011-00645-1	25	4.22
	AVFN	048011-27679-3	10	4.22
	AVFN	048011-04305-0	25	4.22



95299

DISCS  
Scotch-Brite™

## Accessories — Hook-and-Loop



Disc Pad Holder  
No. 905



Disc Pad Holder No.  
917, 915, and 9145

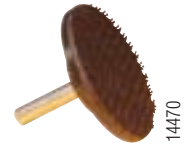

Disc Pad Holder  
No. 922 and 923

### Discs Pad Holders (Hook-and-Loop)

For use with Scotch-Brite™ Surface Conditioning discs.

Dia x Thread	Catalog No.	UPC	Qty./Case	List Price
<b>2"</b> Max RPM 23,000	922	048011-07494-8	10	4.20
<b>3"</b> Max RPM 20,000	923	048011-04132-2	10	4.88
<b>4½" x 5/8"—11 INT</b> Max RPM 13,000	9145	048011-14111-4	1	18.59
<b>5" x 5/8"—11 INT</b> Max RPM 10,000	915	048011-05680-7	1	18.59
<b>5" x 5/16"—24 EXT</b> Max RPM 10,000	905	048011-09448-9	1	19.41
<b>7" x 5/8"—11 INT</b> Max RPM 6,000	917	048011-09450-2	1	20.23



244115

## Scotch-Brite™ Surface Conditioning Discs (cont.)

### Scotch-Brite™ Coating Removal Discs (Hook-and-Loop)

(Silicon Carbide – Extra Coarse)

Made for right-angle tools from aggressive Clean & Strip web. Non-loading design ideal for removing rust and coatings.

Coating Removal Discs are intended to be mounted on hook holders listed below.

Dia	Grade	UPC	Min./Case	List Price
4 1/2"	S XCS	048011-18424-1	4/20	6.72
	S XCS	048011-18482-1	40	6.72
5"	S XCS	048011-18355-8	4/20	8.03
	S XCS	048011-18483-8	40	8.03
7"	S XCS	048011-18358-9	2/10	13.82
	S XCS	048011-18485-2	20	13.82



148166

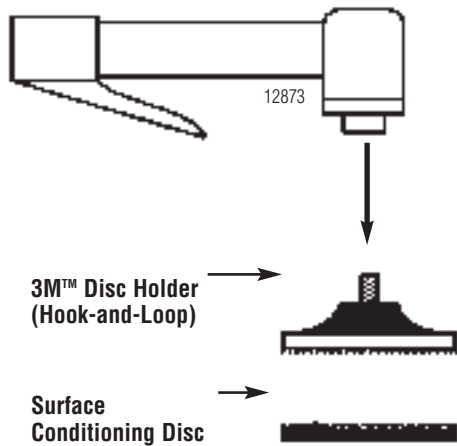

#### Recommended Operating RPMs:

4"	— 5,000 – 8,000 RPMs
4 1/2"	— 4,700 – 7,000 RPMs
5"	— 4,200 – 6,300 RPMs
7"	— 6,000 – 4,500 RPMs

### Accessories – Hook Holders

For use with Scotch-Brite™ Coating Removal Discs.

Dia	Thread	UPC	Min./Case	List Price
5" x 3/4"	5/8"-11 int.	051144-85105-8	1/10	23.28
Max RPM 10,000				
5" x 5/8"	5/8"-11 int.	051144-85096-9	1/10	28.17
Max RPM 10,000				
7" x 1"	5/8"-11 int.	051144-13627-8	1	28.72
Max RPM 6,000				



# 3M™ Stikit™ and PSA Discs Paper-Backing

## 3M™ PSA Disc Roll 316U

(Aluminum Oxide – A wt. Paper)  
Discs for paint, primer, metal, wood and fiberglass.

- Special 3M™ Fre-Cut™ coating resists loading



13270

Dia	Grade	UPC	Discs/ Roll	Min./ Case	List Price
5"	80	051131-01237-0	100	1/6	18.74
	P100	051131-01236-3	100	1/6	16.27
	P120	051131-01235-6	100	1/6	16.27
	P150	051131-01234-9	100	1/6	16.27
	P180	051131-01233-2	100	1/6	16.27
	P220	051131-01232-5	100	1/6	16.27
	P240	051131-01231-8	100	1/6	16.27
	P320	051131-01229-5	100	1/6	16.27

## 3M™ Stikit™ Disc Roll 236U

(Aluminum Oxide – C wt. Paper)  
Discs for paint, primer, wood, metal, plastic and fiberglass.

- Strong paper backing provides durability and increased cut rate
- Open coat minimizes loading
- Invisible 3M™ Fre-Cut™ coating reduces loading



209045

Dia	Grade	UPC	Discs/ Roll	Min./ Case	List Price
5"	P80	051144-86488-1	100	1/4	30.22
	P100	051144-86489-8	100	1/4	27.90
	P120	051144-86490-4	100	1/4	27.90
	P150	051144-86491-1	100	1/4	27.90
	P180	051144-86492-8	100	1/4	27.90
	P220	051144-86493-5	100	1/4	27.90
	P240	051144-86494-2	100	1/4	27.90
	P320	051144-86495-9	100	1/4	27.90
	P400	051144-86496-6	100	1/4	27.90
	P500	051144-86497-3	100	1/4	27.90
6"	P80	051144-86468-3	100	1/4	42.62
	P100	051144-86469-0	100	1/4	39.35
	P120	051144-86470-6	100	1/4	39.35
	P150	051144-86471-3	100	1/4	39.35
	P180	051144-86472-0	100	1/4	39.35
	P220	051144-86473-7	100	1/4	39.35
	P240	051144-86474-4	100	1/4	39.35
	P320	051144-86475-1	100	1/4	39.35
	P400	051144-86476-8	100	1/4	39.35
	P500	051144-86477-5	100	1/4	39.35



121615

## 3M™ Stikit™ Disc Roll 363I

(Aluminum Oxide – F wt. Paper)

- Extra heavy paper backing
- Resin bonded for heat resistance
- Primary markets: metalworking, woodworking



105-480

Dia	Grade	UPC	Discs/ Roll	Qty/ Case	List Price
5" X NH 363I	60	051144-21800-4	100	4	52.61
	80	051144-21799-1	100	4	47.65
	P100	051144-21798-4	100	4	44.04
	P120	051144-21797-7	100	4	44.04
	P150	051144-21796-0	100	4	44.04
	P180	051144-21795-3	100	4	44.04
6" X NH 363I	60	051144-21794-6	100	4	72.03
	80	051144-21793-9	100	4	64.81
	P100	051144-21792-2	100	4	59.85
	P120	051144-21791-5	100	4	59.85
	P150	051144-21790-8	100	4	59.85
	P180	051144-21789-2	100	4	59.85

## 3M™ Stikit™ Disc Roll 763U

(3M™ Cubitron™ – F wt. Paper)

- Extra heavy paper backing
- Primary markets: metalworking, woodworking

Dia	Grade	UPC	Discs/ Roll	Qty/ Case	List Price
5" X NH 763U	60	051144-80942-4	100	4	76.41
	80	051144-80943-1	100	4	69.20
	P100	051144-80944-8	100	4	63.95
	P120	051144-80945-5	100	4	63.95
6" X NH 763U	60	051144-80946-2	100	4	104.61
	80	051144-80947-9	100	4	94.11

# 3M™ Stikit™ and PSA Discs Cloth-Backing

## 3M™ Stikit™ Disc 300D

- (Aluminum Oxide – J wt. Cloth – Open Coat)  
Excellent for all types of wood and metal sanding.
- Cloth backing provides excellent durability
  - Open coat resists loading
  - Individual discs with liners

Dia	Grade	UPC	Min./Case	List Price
5" 300D	80	051111-50450-5	50/250	0.39
	P100	051111-50451-2	50/250	0.38
	P120	051111-50452-9	50/250	0.38
	P150	051111-50453-6	50/250	0.38
	P180	051111-50454-3	50/250	0.38
6" 300D	P220	051111-50455-0	50/250	0.38
	80	051111-50459-8	50/250	0.57
	P100	051111-50460-4	50/250	0.54
	P120	051111-50461-1	50/250	0.54
	P150	051111-50462-8	50/250	0.54
6" 300D	P180	051111-50463-5	50/250	0.54
	P220	051111-50464-2	50/250	0.54



## 3M™ Stikit™ Disc Roll 241D

- (Aluminum Oxide – X wt. Cloth)
- Durable cloth backing
  - Resin bonded for heat resistance
  - Primary market: metalworking

Dia	Grade	UPC	Discs/ Roll	Qty./ Case	List Price
5" X NH 241D	P50	051144-21752-6	100	4	70.21
	P60	051144-21751-9	100	4	66.22
	P80	051144-21750-2	100	4	61.35
	P100	051144-21749-6	100	4	58.25
	P120	051144-21748-9	100	4	58.25
	P150	051144-21747-2	100	4	58.25
6" X NH 241D	P180	051144-21746-5	100	4	58.25
	P60	051144-21762-5	100	4	92.48
	P80	051144-21761-8	100	4	86.14

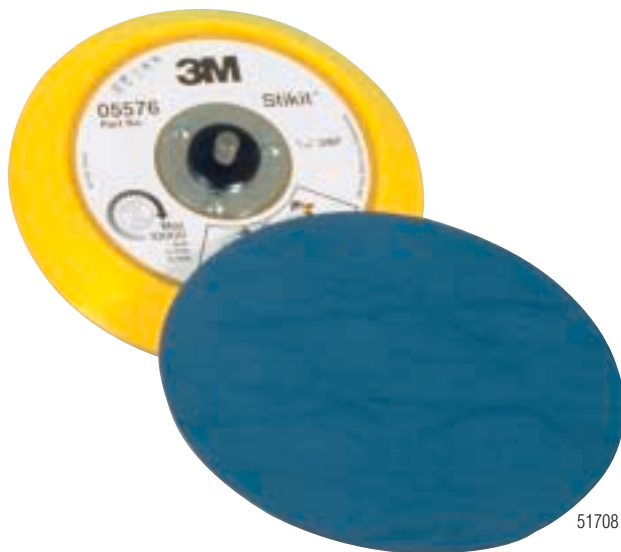

## 3M™ Stikit™ Disc Pads

Lightweight pads have vinyl face for excellent disc adhesion with quick, easy disc removal. For use with Stikit™ Discs and PSA Disc Roll 316U.

Dia x Thickness x Thread Size	UPC	Min./Case	List Price
5" x 3/4" x 5/16"–24 Max RPM 10,000 Max OPM* 12,000	051144-05575-3	1/10	18.76
6" x 3/4" x 5/16"–24 Max RPM 10,000 Max OPM* 12,000	051144-05576-0	1/10	20.87

\* Orbits per minute

## 3M™ Stikit™ and PSA Discs Cloth-Backing (cont.)

### 3M™ PSA Discs 248D

(Aluminum Oxide – X wt. Cloth)

Heavy-duty cloth-backed discs for more aggressive applications. Provides excellent adhesion while removing easily.

Dia	Grade	UPC	Min./Case	List Price
2"	P36	051144-20913-2	50/200	0.52
	P50	051144-20911-8	50/200	0.47
	P60	051144-20910-1	50/200	0.46
	P80	051144-20909-5	50/200	0.43
	P100	051144-20908-8	50/200	0.41
	P120	051144-20907-1	50/200	0.41
3"	P40	051144-01335-7	50/200	0.56
	P50	051144-01334-0	50/200	0.54
	P60	051144-01333-3	50/200	0.52
	P80	051144-01332-6	50/200	0.50
	P100	051144-01331-9	50/200	0.48
	P120	051144-01330-2	50/200	0.48
5"	P36	051144-20891-3	50/250	0.83
	P40	051144-20890-6	50/250	0.78
	P50	051144-20889-0	50/250	0.74
	P60	051144-20888-3	50/250	0.71
	P80	051144-20887-6	50/250	0.67
	P100	051144-20886-9	50/250	0.65
	P120	051144-20885-2	50/250	0.65
	P150	051144-20884-5	50/250	0.65
	P180	051144-20883-8	50/250	0.65
	P240	051144-20881-4	50/250	0.65
6"	P36	051144-21639-0	50/250	1.23
	P40	051144-21731-1	50/250	1.18
	P50	051144-20879-1	50/250	1.10
	P60	051144-20878-4	50/250	1.04
	P80	051144-20877-7	50/250	0.98
	P100	051144-20876-0	50/250	0.92
8"	P120	051144-21497-6	50/250	0.92
	P36	051144-20874-6	50/250	2.19
	P40	051144-20873-9	50/250	2.09
	P60	051144-20871-5	50/250	1.89
	P80	051144-20870-8	50/250	1.80
	P120	051144-20868-5	50/250	1.71
12"	P36	051144-88906-8	10	5.11
	P40	051144-88905-1	10	4.82
	P50	051144-88904-4	10	4.55
	P60	051144-88903-7	10	4.28
	P80	051144-88902-0	10	4.04
	P100	051144-88901-3	10	3.82
16"	P36	051144-88890-0	10	9.40
	P40	051144-88889-4	10	8.86
	P60	051144-88887-0	10	7.90
	P80	051144-88886-3	10	7.44
18"	P36	051144-88882-5	10	11.92
	P60	051144-88880-1	10	10.01
20"	P36	051144-88878-8	10	14.48
	P40	051144-88877-1	10	13.67
	P50	051144-88876-4	10	12.90
	P60	051144-88875-7	10	12.17
	P80	051144-88874-0	10	11.48
24"	P36	051144-20802-9	10	20.70
	P40	051144-20801-2	10	19.34
	P80	051144-20798-5	10	15.91



159120

### 3M™ PSA Disc 778F

(3M™ Cubitron™ Abrasive Grain-Polyester Cloth)

Heavy-duty polyester cloth backing provides great strength and flexibility. 3M™ Cubitron™ abrasive grain provides long life and fast cut on multiple substrates.

Dia	Grade	UPC	Qty./Case	List Price
12"	36YF	051144-88869-6	10	10.08
	40YF	051144-88873-3	10	9.51
	50YF	051144-88872-6	10	8.97
	60YF	051144-88871-9	10	8.45
	80YF	051144-88870-2	10	7.98

## Accessories

### PSA Disc Holders

Supports 248D PSA disc and can be used with any air or electric grinding tool that accommodates a 1/4" shank.



Dia	UPC	Min./Case	List Price
2" Max RPM 15,000	051144-45070-1	1	19.25
3" Max RPM 10,000	051144-05510-4	1/10	19.46
5" Max RPM 6,000	051144-45068-8	1	29.13

# 3M™ Belts

## Portable Tool Belts

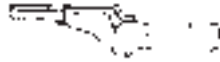

### 3M™ Trizact™ CF Belts

- Macroreplicated structure provides long product life and consistent cut and finish
- Designed specifically for intermediate finishing in the turbine blade and medical implant markets



W x L	Grade	UPC	Qty./Case	List Price
1/2" x 24"	A300	048011-33136-2	20	1.67
	A160	048011-33137-9	20	1.67
	A100	048011-33138-6	20	1.67
	A65	048011-33139-3	20	1.67
	A45	048011-33140-9	20	1.67



242744

### 241D

(Aluminum Oxide – X wt. Cloth)

- Excellent all-around abrasive belt for blending and finishing



14351

W x L	Grade	UPC	Min./Case	List Price
3 1/2" x 15 1/2"	60	051144-26857-3	10/50	2.14
	80	051144-26856-6	10/50	1.94
	120	891040-02663-0	10/50	1.82

### 241E/251E

(Grades 50 and finer are 241E/  
Grades 40 and coarser are 251E)  
(Aluminum Oxide – XE wt. Cloth)

- High strength backing for tougher applications



51721

W x L	Grade	UPC	Min./Case	List Price	
1/4" x 24"	60	051144-26733-0	50/200	1.03	
	241E	80	051144-26732-3	50/200	1.00
1/2" x 12"	60	051144-31170-5	50/200	1.03	
	80	051144-26894-8	50/200	1.00	
	241E	120	051144-26892-4	50/200	0.97
1/2" x 18"	60	051144-72227-3	50/200	1.08	
	80	051144-72228-0	50/200	1.05	
	241E	120	051144-72229-7	50/200	1.02
1/2" x 24"	36	051144-32375-3	50/200	1.78	
	50	051144-26725-5	50/200	1.18	
	60	051144-26723-1	50/200	1.13	
	80	051144-26720-0	50/200	1.10	
	241E/251E	100	051144-26719-4	50/200	1.06
	Aluminum Oxide	120	051144-26717-0	50/200	1.06
		150	051144-26716-3	50/200	1.06
	180	051144-26715-6	50/200	1.06	
3/4" x 18"	60	051144-14756-4	50/200	1.16	
	80	051144-14519-5	50/200	1.13	
	241E/251E	100	051144-77280-3	50/200	1.09
		120	051144-14667-3	50/200	1.09
3/4" x 20 1/2"	80	051144-26780-4	50/200	1.16	
	241E	120	051144-26778-1	50/200	1.12

### 777F

(Premium 3M™ Cubitron™ Abrasive Grain and Aluminum Oxide mineral)

- Can be run wet or dry
- Features built-in grinding runs cool to prevent surface warping and discoloration

W x L	Grade	UPC	Min./Case	List Price
1/4" x 24"	40	051144-84412-8	50/200	2.06
	60	051144-80253-1	50/200	1.89
	80	051144-77642-9	50/200	1.72
	120	051144-82229-4	50/200	1.68
1/2" x 18"	40	051144-84409-8	50/200	2.16
	60	051144-80551-8	50/200	1.99
	80	051144-80232-6	50/200	1.81
1/2" x 24"	120	051144-84304-6	50/200	1.77
	36	051144-77643-6	50/200	2.49
	40	051144-82342-0	50/200	2.26
1/2" x 24"	50	051144-77408-1	50/200	2.16
	60	051144-77065-6	50/200	2.07
	80	051144-77491-3	50/200	1.90
	120	051144-81064-2	50/200	1.85
3/4" x 18"	36	051144-84302-2	50/200	2.55
	60	051144-84404-3	50/200	2.13
	80	051144-77992-5	50/200	1.94
3/4" x 20 1/2"	120	051144-84303-9	50/200	1.90
	60	051144-80486-3	50/200	2.18
	80	051144-80686-7	50/200	2.00
3 1/2" x 15 1/2"	36	051144-77336-7	10/50	8.01
	50	051144-77334-3	10/50	6.94
	60	051144-77476-0	10/50	6.68
	80	051144-77333-6	10/50	6.11
	100	051144-84306-0	10/50	5.96
	120	051144-84307-7	10/50	5.96
	180	051144-85320-5	10/50	5.96

**ATTENTION:** Belts are available in other grades and sizes. If you don't find the specific belt you need, contact your 3M Sales Specialist or 3M Authorized Distributor.

# 3M™ Backstand and Bench-Top Belts

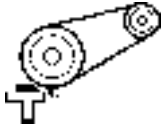

## 241D

(Aluminum Oxide – X wt. Cloth)

- Excellent all around abrasive belt for everyday use



51724

W x L	Grade	UPC	Min./Case	List Price
1" x 42"	P36	051144-26614-2	50/200	1.64
	P50	051144-31823-0	50/200	1.46
	P60	891040-01450-7	25/100	1.35
	P80	891040-01451-4	25/100	1.23
	P100	891040-01452-1	25/100	1.15
	P120	891040-01453-8	25/100	1.15
	P150	051144-26602-9	50/200	1.15
	P180	051144-26601-2	50/200	1.15
	P240	051144-26599-2	50/200	1.15
	P320	051144-26597-8	50/200	1.15
1½" x 60"	P36	051144-26443-8	10/50	2.33
	P40	051144-26441-4	10/50	2.24
	P50	051144-26440-7	10/50	2.07
	P60	051144-26438-4	25/50	1.92
	P80	051144-26436-0	25/50	1.74
2" x 48"	P36	051144-26571-8	10/50	2.42
	P50	051144-26568-8	10/50	2.15
	P60	051144-26564-0	25/50	1.99
	P80	051144-26562-6	25/50	1.81
	P100	051144-26561-9	25/50	1.69
	P120	051144-26560-2	25/50	1.69
2" x 60"	P36	051144-26426-1	10/50	2.76
	P50	051144-26424-7	10/50	2.45
	P60	051144-33640-1	25/50	2.28
	P80	051144-33639-5	25/50	2.06
	P120	051144-33667-8	25/50	1.94
2" x 72"	P36	051144-26320-2	10/50	3.11
	P60	051144-26316-5	25/50	2.56
	P80	051144-33067-6	25/50	2.32
	P120	051144-26312-7	25/50	2.18
	P180	051144-26309-7	25/50	2.18
	P240	051144-81752-8	25/50	2.18
2½" x 60"	P36	051144-26408-7	10/50	3.45
	P50	051144-26404-9	10/50	3.06
	P60	051144-26400-1	25/50	2.84
	P80	051144-26396-7	25/50	2.58
	P120	051144-26388-2	25/50	2.42
6" x 48"	P36	891040-01454-5	10/20	7.25
	P40	891040-01455-2	10/20	6.97
	P50	891040-01456-9	10/20	6.44
	P60	891040-01457-6	10/20	5.97
	P80	891040-10454-3	20	5.42
	P100	891040-10455-0	20	5.08
	P120	891040-10456-7	20	5.08
	P150	051144-26517-6	20	5.08
	P180	051144-26515-2	20	5.08
	P240	051144-26513-8	20	5.08



312049

## 963G

(Premium 3M™ Cubitron™ Abrasive Grain – YN wt. Cloth)

- Water-resistant polyester cloth backing for heavy grinding
- Can be run wet or dry

W x L	Grade	UPC	Min./Case	List Price
2" x 48"	36	051144-14557-7	10/50	6.86
	60	051144-13533-2	25/50	5.29
	80	051144-13714-5	25/50	4.85
2" x 132"	36	051144-74025-3	10/50	13.72
	50	051144-11255-5	10/50	11.20
	80	051144-11253-1	25/50	9.72
3" x 132"	36	051144-74207-3	5/50	20.59
	60	051144-74324-7	25/50	15.88
	80	051144-13715-2	25/50	14.57
4" x 132"	36	051144-74209-7	5/50	27.46
	50	051144-74354-4	5/50	22.41
	80	051144-74325-4	25/50	21.19



51686

**ATTENTION:** Belts are available in other grades and sizes. If you don't find the specific belt you need, contact your 3M Sales Specialist or 3M Authorized Distributor.

## 3M™ Backstand and Bench-Top Belts (cont.)

### 777F

(3M™ Cubitron™ Abrasive Grain Blend – YF wt. Cloth)

- Contains grinding aid which enhances performance on stainless steel and other exotic alloys

W x L	Grade	UPC	Min./Case	List Price
1" x 42"	40	051144-76527-0	50/200	4.13
	60	051144-77512-5	50/200	3.80
	80	051144-14895-0	50/200	3.48
1½" x 60"	60	051144-84416-6	25/50	5.40
	80	051144-76731-1	25/50	4.94
	P120	051144-82022-1	25/50	4.81
2" x 48"	36	051144-76738-0	10/50	6.72
	60	051144-76519-5	25/50	5.60
	80	051144-14896-7	25/50	5.13
2" x 60"	36	051144-77663-4	10/50	7.68
	60	051144-77152-3	25/50	6.40
	80	051144-84296-4	25/50	5.86
	P120	051144-85377-9	25/50	5.71
2" x 72"	36	051144-76531-7	10/50	8.64
	60	051144-80286-9	25/50	7.20
	80	051144-14884-4	25/50	6.59
	P120	051144-81767-2	25/50	6.41
2" x 132"	60	051144-82231-7	25/50	11.20
	80	051144-14534-8	25/50	10.25
	P120	051144-81687-3	25/50	9.98
	P180	051144-84315-2	25/50	9.98
2½" x 60"	36	051144-76532-4	10/50	9.60
	40	051144-77825-6	10/50	8.72
	60	051144-76680-2	25/50	8.00
	80	051144-76686-4	25/50	7.32
3" x 132"	36	051144-76533-1	5/50	20.16
	60	051144-76520-1	25/50	16.80
	80	051144-76514-0	25/50	15.37
	P120	051144-80028-5	25/50	14.98
	P180	051144-85762-3	25/50	14.98
4" x 132"	80	051144-76515-7	25/50	20.50
	P120	051144-81443-5	25/50	19.97
6" x 48"	36	051144-82313-0	10/20	20.16
	50	051144-80176-3	10/20	17.45
	60	051144-76679-6	20	16.80
	80	051144-76733-5	20	15.37
	P120	051144-82153-2	20	14.98



159098

### 977F

(3M™ Cubitron™ Abrasive Grain Blend– YF wt. Cloth)

- Recommended for both wet or dry grinding of stainless steel and high nickel alloys
- Works well in all grinding pressures

W x L	Grade	UPC	Min./Case	List Price
2" x 132"	36	051144-83522-5	10/50	14.56
	50	051144-85015-0	10/50	11.96
	60	051144-85384-7	25/50	11.27
	80	051144-85769-2	25/50	10.25

### 3M™ Trizact™ 237AA

- Ideal for metal finishing applications requiring a semi-flexible abrasive
- Resin bonded for heat resistance
- Features a grinding aid for cooler grinding



60872

W x L	Grade	UPC	Min./Case	List Price
3" x 132"	A100	051111-51213-5	25/50	19.16
	A45	051111-51209-8	25/50	19.16
	A30	051111-51207-4	25/50	19.16
	A16	051111-51199-2	25/50	19.16
4" x 132"	A45	051111-51212-8	25/50	23.42
	A30	051111-51214-2	25/50	25.55
	A16	051111-69017-8	25/50	25.55



14442

**ATTENTION:** Belts are available in other grades and sizes. If you don't find the specific belt you need, contact your 3M Sales Specialist or 3M Authorized Distributor.

## 3M™ Backstand and Bench-Top Belts (cont.)

### 3M™ Trizact™ 307EA

- Ideal for critical preplate surface finishing
- Flexible rayon cloth backing
- Features grinding aid for cooler grinding



60872

W x L	Grade	UPC	Min./Case	List Price
2" x 132"	A100	051111-69080-2	25/50	10.83
	A80	051111-69077-2	25/50	10.83
	A65	051111-69075-8	25/50	10.83
	A45	051111-51210-4	25/50	10.83
	A30	051111-69068-0	25/50	10.83
	A16	051111-51202-9	25/50	10.83
3" x 132"	A6	051111-51206-7	25/50	10.83
	A80	051111-69078-9	25/50	16.24
	A45	051111-69073-4	25/50	16.24
	A30	051111-51201-2	25/50	16.24
	A16	051111-51200-5	25/50	16.24

### 3M™ Trizact™ CF

- Macroreplicated structure provides long product life and consistent cut and finish
- Designed specifically for intermediate finishing in the turbine blade and medical implant markets



W x L	Grade	UPC	Qty./Case	List Price
2" x 132"	A300	048011-33162-1	5	10.00
	A160	048011-33163-8	5	10.00
	A100	048011-33164-5	5	10.00
	A65	048011-33165-2	5	10.00
	A45	048011-33166-9	5	10.00
3" x 132"	A300	048011-33167-6	5	15.01
	A160	048011-33168-3	5	15.01
	A100	048011-33169-0	5	15.01
	A65	048011-33170-6	5	15.01
	A45	048011-33171-3	5	15.01

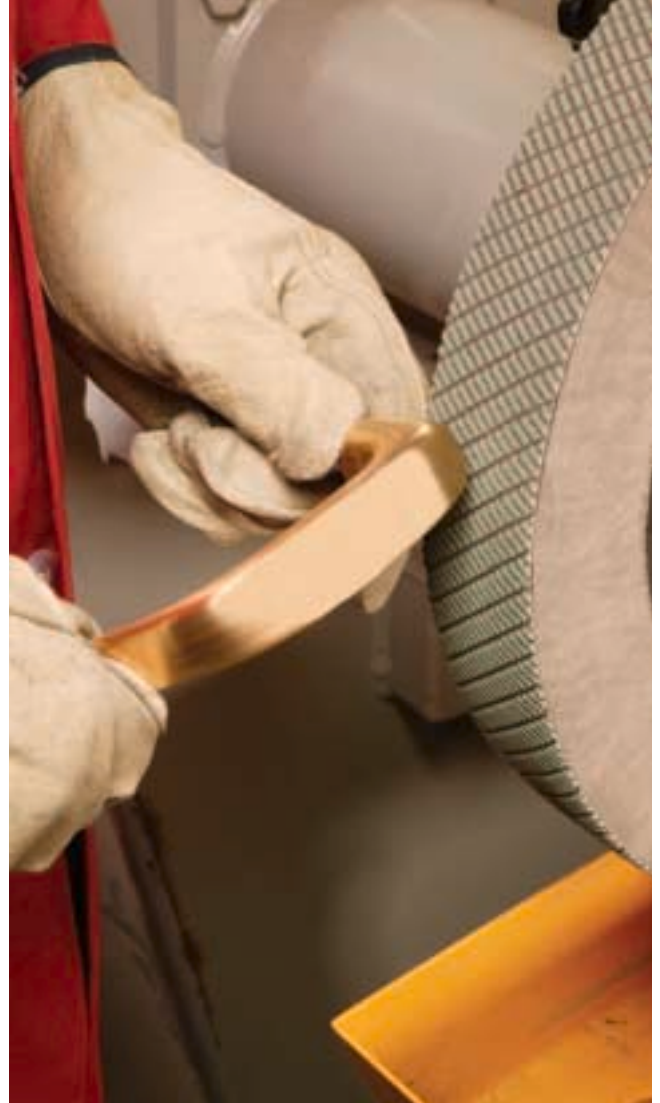

311760

Backstand  
Benchtop

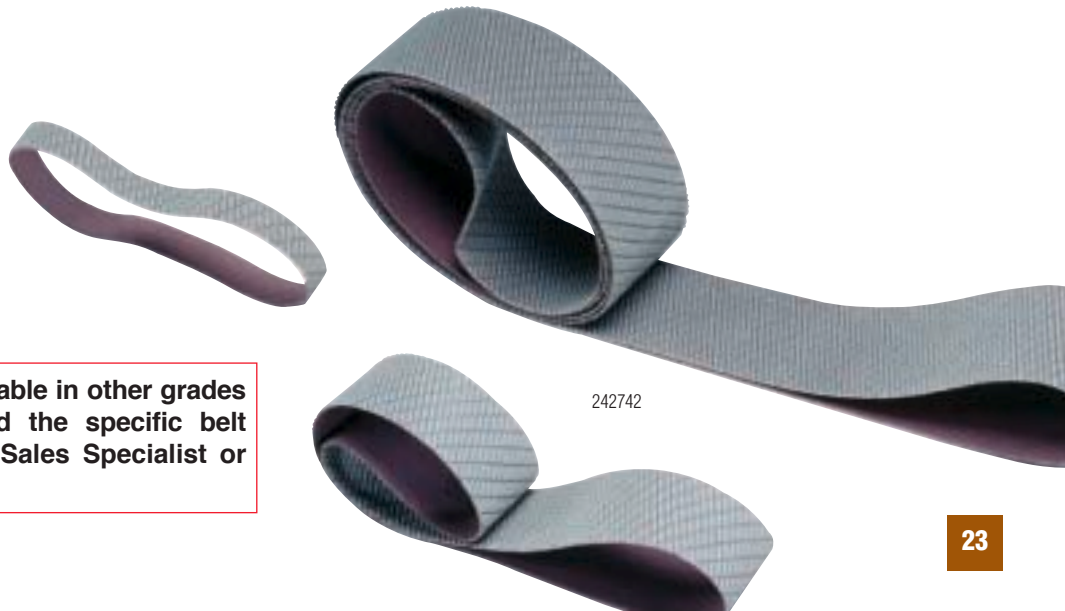

242742

**ATTENTION:** Belts are available in other grades and sizes. If you don't find the specific belt you need, contact your 3M Sales Specialist or 3M Authorized Distributor.

# Scotch-Brite™ Surface Conditioning Belts

Premium Scotch-Brite™ surface conditioning non-woven web. Designed for:

- Cleaning
- Finishing
- Light deburring

A VFN – Blue

A MED – Maroon

A CRS – Brown

W x L	Grade	UPC	Qty./Case	List Price
1/2" x 18"	A CRS	048011-08858-7	20	4.40
	A MED	048011-08857-0	20	4.40
	A VFN	048011-08856-3	20	4.40
1/2" x 24"	A CRS	048011-05741-5	20	4.67
	A MED	048011-03998-5	20	4.67
	A VFN	048011-04299-2	20	4.67
3/4" x 18"	A CRS	048011-13639-4	20	6.13
	A MED	048011-15899-0	20	6.13
	A VFN	048011-14543-3	20	6.13
1" x 42"	A MED	048011-04189-6	10	10.17
	A VFN	048011-04190-2	10	10.17
2" x 48"	A MED	048011-08915-7	10	16.68
	A VFN	048011-04295-4	10	16.68
2" x 72"	A MED	048011-00580-5	10	21.28
	A VFN	048011-00579-9	10	21.28
2" x 132"	A MED	048011-03999-2	5	32.80
	A VFN	048011-04297-8	5	32.80
2 3/4" x 15 1/2"	A CRS	048011-05022-5	10	14.82
	A MED	048011-05227-4	10	14.82
3" x 10 1/16"	A CRS	048011-05820-7	10	13.38
	A MED	048011-05783-5	10	13.38
	A VFN	048011-09650-6	10	13.38
3" x 18"	A MED	048011-14285-2	10	15.40
	A VFN	048011-14550-1	10	15.40
3" x 24"	A CRS	048011-08880-8	10	17.14
	A MED	048011-00583-6	10	17.14
	A VFN	048011-04298-5	10	17.14
3" x 132"	A CRS	048011-05023-2	5	48.35
	A MED	048011-00568-3	5	48.35
	A VFN	048011-04289-3	5	48.35
3 1/2" x 15 1/2"	A CRS	048011-05016-4	10	19.36
	A MED	048011-05228-1	10	19.36
	A VFN	048011-05643-2	10	19.36
6" x 48"	A CRS	048011-05019-5	5	47.15
	A MED	048011-00590-4	5	47.15
	A VFN	048011-04283-1	5	47.15

## Recommended operating speeds:

Application	Recommended SFPM
Decorative Finishing	500–3,000 SFPM
Deburring	5,000–6,500 SFPM
Cleaning and Conditioning	2,000–5,000 SFPM
Oxide Removal	4,500–6,500 SFPM

SFPM = Surface Feet Per Minute

Maximum Operating Speed: 6,500 SFPM



159130



# Wheels

## Scotch-Brite™ Unitized Wheels

### Scotch-Brite™ EXL Unitized Deburring Wheels

Excellent for deburring and polishing a wide range of metals, plastics and composites.

- Cool running allows more pressure to be applied
- Cleaner than buffs and compounds

Dia x W x AH	Grade	Max RPM	UPC	Qty./Case	List Price
1" x 1" x 3/16"	2A MED	25,100	048011-15527-2	50	2.78
	2S FIN	30,100	048011-13713-1	50	2.78
	6A MED	35,100	048011-14063-6	50	3.28
	6S FIN	35,100	048011-15859-4	50	3.28
	8A MED	35,100	048011-13753-7	50	3.64
	8A CRS	35,100	048011-13752-0	50	3.64
3" x 1/4" x 3/8"	2A MED	12,100	048011-16054-2	40	4.92
	2S FIN	12,100	048011-14750-5	40	4.92
	4A FIN	18,100	048011-14751-2	40	5.27
	6A MED	18,100	048011-15118-2	40	5.79
	6S FIN	18,100	048011-14752-9	40	5.79
	8A MED	18,100	048011-14753-6	40	6.43
6" x 1/2" x 1"	2S FIN	5,000	048011-14379-8	4	26.29
	2A MED	4,500	048011-16545-5	4	26.29
6" x 1" x 1"	2S FIN	5,000	048011-13743-8	2	46.72
	2A MED	4,500	048011-16544-8	2	46.72

For 1", use Mandrel No. 936 or 946

For 3", use Mandrel No. 990

## Accessories

### Mandrels



Mandrel No. 946



Mandrel No. 990

Designed for use with Scotch-Brite™ Unitized Wheels.

L x Shaft Dia x Washer Dia	Catalog No.	UPC	Qty./Case	List Price
2 1/16" x 1/4" x 3/4" Plastic	936	048011-04018-9	5	4.69
1 3/4" x 1/4" Max RPM 18,200 with 3" wheel	990	048011-15012-3	5	15.13



51730

### Scotch-Brite™ Roloc™ EXL Unitized Wheels

Strong, efficient products for edge deburring and finishing. Used with 3M™ Roloc™+ holder pads on a straight shaft or right-angle tool.



179831

Dia	Grade	UPC	Qty./Case	List Price
2"	6A MED	048011-17190-6	60	3.40
	2A MED	048011-17185-2	60	2.89
	2S FIN	048011-17183-8	60	2.89
3"	6A MED	048011-17191-3	40	6.20
	2A MED	048011-17186-9	40	5.27
	2S FIN	048011-17184-5	40	5.27

### 3M™ Roloc™+ Holder

Plastic holder for use with 3M™ Roloc™ Unitized Wheels.



51732

L x Shaft Dia	UPC	Qty./Case	List Price
1" x 1/4" Max RPM 25,000	048011-15408-4	5	11.35

# Scotch-Brite™ Convolute Wheels

## Scotch-Brite™ EXL Deburring Wheels

Use to clean, finish, blend, deburr or polish all types of metals, composites and glass.



144779

Dia x W x AH	Grade	UPC	Qty./Case	List Price
6" x 1/2" x 1" Max RPM 6,000	8A MED	048011-13616-5	4	36.54
	8S FIN	048011-09548-6	4	36.54
	9S FIN	048011-05790-3	4	36.54
6" x 1" x 1" Max RPM 6,000	8A MED	048011-13617-2	3	51.16
	8S FIN	048011-09549-3	3	51.16
	9S FIN	048011-05132-1	3	51.16
8" x 1/2" x 3" Max RPM 4,500	8A MED	048011-17459-4	4	43.48
	8S FIN	048011-14629-4	4	43.48
	9S FIN	048011-05791-0	4	43.48
8" x 1" x 3" Max RPM 4,500	8A MED	048011-13619-6	3	63.98
	8S FIN	048011-09551-6	3	63.98
	9S FIN	048011-05135-2	3	63.98
8" x 2" x 3" Max RPM 4,500	8A MED	048011-13620-2	2	111.56
	8S FIN	048011-09552-3	2	111.56
	9S FIN	048011-05136-9	2	111.56

## Scotch-Brite™ SF Finishing and Deburring Wheels

When your main task is finishing but you know you have some burrs.

- Fast, consistent and easy on operators
- Finish all types of metals, composites and glass



241317

Dia x W x AH	Grade	UPC	Qty./Case	List Price
6" x 1/2" x 1" Max RPM 6,000	8S FIN	048011-33174-4	4	35.72
	8S MED	048011-33184-3	4	35.72
6" x 1" x 1" Max RPM 6,000	8S FIN	048011-33182-9	3	50.01
	8S MED	048011-33185-0	3	50.01

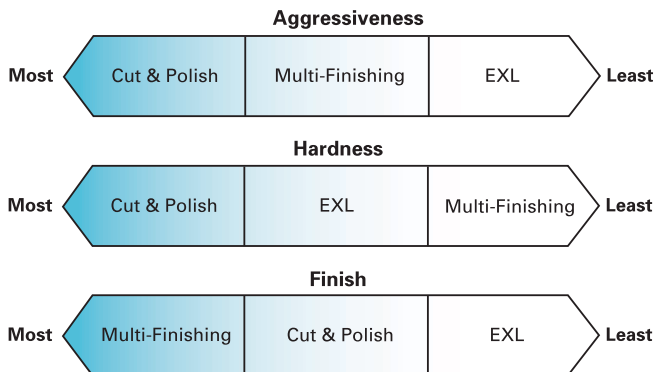

## Scotch-Brite™ Multi-Finishing Wheels

Produces uniform grain finishes on stainless steel and other metals.

- Highly conformable
- Tough enough to finish edges and welds



51736

Dia x W x AH	Grade	UPC	Qty./Case	List Price
6" x 1" x 1" Max RPM 6,000	2S CRS	048011-13170-2	3	30.33
	2S MED	048011-13171-9	3	30.33
	2S FIN	048011-13172-6	3	30.33
6" x 2" x 1" Max RPM 6,000	2S CRS	048011-13176-4	2	50.26
	2S MED	048011-13177-1	2	50.26
	2S FIN	048011-13178-8	2	50.26
8" x 1" x 3" Max RPM 4,500	2S CRS	048011-13182-5	3	47.67
	2S MED	048011-13183-2	3	47.67
	2S FIN	048011-13184-9	3	47.67
8" x 2" x 3" Max RPM 4,500	2S CRS	048011-13185-6	2	74.38
	2S MED	048011-13186-3	2	74.38

## Scotch-Brite™ Cut & Polish Wheels

Heavy-duty wheels for aggressive blending and finishing.

- Produce uniform results quickly and easily
- Replace rubber bonded wheels, set-up wheels and flap wheels



51737

Dia x W x AH	Grade	UPC	Qty./Case	List Price
6" x 1" x 1" Max RPM 6,000	7A MED	048011-03262-7	3	91.13
	7A FIN	048011-03270-2	3	91.13

## Accessories – Wheels

### Flange Adapter No. 5

For use with 6" wheels. Telescoping wheel adapters 1" and 1/2" wide to reduce 1" wheel cores to fit 3/8". Must be used with side flanges.



51738

OD x W x ID	UPC	Qty./Case	List Price
1" x 1/2" x 1/2"	048011-16859-3	1 Pair	3.56/Pair
1" x 1" x 1/2"	048011-16860-9	1 Pair	4.07/Pair

A prefix denotes the mineral in the product (e.g., AFIN):

- A = Aluminum Oxide mineral
- S = Silicon Carbide mineral

When a number appears, this denotes the density of the product (e.g., 2 SMED) soft ← → hard

2	6	7	8	9
---	---	---	---	---

# 3M™ Flap Wheels

## 3M™ Flap Wheel 244E/241E/741A

(Grades 60, 80, 120 are 244E/  
Grades 50, 100, 150, 220 are 241E)  
(Aluminum Oxide – XE wt. Cloth)  
General purpose flap wheel delivers  
consistent finish and uniform cut.  
741A combines the characteristics  
of aluminum oxide mineral with  
3M™ Cubitron™ Abrasive Grain  
on a strong X-weight backing.

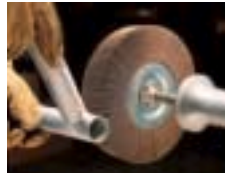

51742

Dia x W x AH	Grade	UPC	Qty./Case	List Price
<b>6" x 1" x 1"</b> 241E/244E Max RPM 6,100	60	051144-35113-8	5	17.37
	80	051144-35112-1	5	18.54
	100	051144-35111-4	5	18.32
	120	051144-35109-1	5	20.11
<b>6" x 1" x 1"</b> 741A Max RPM 6,100	50	051144-82770-1	5	16.80
	60	051144-81986-7	5	17.18
	80	051144-81984-3	5	18.35
<b>6" x 2" x 1"</b> 241E/244E Max RPM 5,200	60	051144-35088-9	5	29.08
	80	051144-35086-5	5	30.84

## Accessories — Flap Wheels

### Wheel Adapter Kit No. 3

Two arbor hole (plug type) adapters  
for 6" and 8" diameter flap wheels.  
1" O.D. x various I.D.'s.



78424

ID	UPC	Qty./Case	List Price
1/2"	051144-45035-0	1	3.31
5/8"	051144-45034-3	1	3.31
3/4"	051144-45033-6	1	3.31
7/8"	051144-45032-9	1	3.31



51741

## 3M™ Mounted Flap Wheels 244E

(Aluminum Oxide)

General purpose flap wheel delivers consistent finish  
and uniform cut.



T83 –  
1/4" straight



T84 –  
1/4" x 20 threaded

Dia x W x Shk	Grade	UPC	Qty./Case	List Price
<b>T83 – 1/4" Straight</b>				
<b>1" x 1" x 1/4"</b> Max RPM 30,000	60	051144-35475-7	10	3.10
	80	051144-35476-4	10	3.10
	120	051144-35477-1	10	3.10
<b>2" x 1" x 1/4"</b> Max RPM 25,000	60	051144-14623-9	10	5.01
	80	051144-14624-6	10	5.01
	120	051144-14625-3	10	5.01
<b>3" x 1" x 1/4"</b> Max RPM 20,000	60	051144-14655-0	10	6.20
	80	051144-14656-7	10	6.20
	120	051144-14657-4	10	6.20
<b>T84 – 1/4" x 20 Threaded</b>				
<b>1" x 1" x 1/4"-20</b> Max RPM 30,000	60	051144-35467-2	10	3.10
	80	051144-35468-9	10	3.10
	120	051144-35469-6	10	3.10
<b>2" x 1" x 1/4"-20</b> Max RPM 25,000	60	051144-14575-1	10	5.01
	80	051144-14576-8	10	5.01
	120	051144-14577-5	10	5.01
<b>3" x 1" x 1/4"-20</b> Max RPM 20,000	60	051144-14607-9	10	6.20
	80	051144-14608-6	10	6.20
	120	051144-14609-3	10	6.20

## 3M™ Flap Wheels 747D Type 83 and Type 84

3M™ Cubitron™ Abrasive Grain blend on a resin-bonded  
X-wt. cloth backing. Includes a grinding aid for cooler running  
on stainless steel.

Dia x W x Shank	Grade	UPC	Min./Case	List Price
<b>T83 – 1/4" Straight</b>				
<b>1" x 1" x 1/4"</b> Type 83	60	051144-80761-1	50/200	5.24
	80	051144-80757-4	50/200	5.24
	P120	051144-80753-6	50/200	5.24
<b>2" x 1" x 1/4"</b> Type 83	60	051144-80763-5	50/200	6.96
	80	051144-80759-8	50/200	6.96
	P120	051144-80755-0	50/200	6.96
<b>3" x 1" x 1/4"</b> Type 83	60	051144-80650-8	50/200	7.87
	80	051144-80651-5	50/200	7.87
	P120	051144-80652-2	50/200	7.87
<b>T84 – 1/4" x 20 Threaded</b>				
<b>2" x 1" x 1/4"</b> Type 84	60	051144-83271-2	50/200	6.96
	80	051144-83268-2	50/200	6.96
	P120	051144-83265-1	50/200	6.96
<b>3" x 1" x 1/4"</b> Type 84	60	051144-83269-9	50/200	7.87
	80	051144-83267-5	50/200	7.87
	P120	051144-83263-7	50/200	7.87

# Cut-Off Wheels

## 3M™ Green Corps™ Cut-Off Wheels

Green Corps™ Cut-Off wheels incorporate 3M's patented Cubitron™ abrasive grain, an advanced ceramic aluminum oxide mineral. They provide high cut rates and long life on most material, including fiberglass, stainless steel and mild steel. Do not use on tools without guards.



159135

Dia x W x AH	UPC	Min./Case	List Price
<b>2" x 1/16" x 1/4"</b> Max RPM 42,000	051144-83487-7	50/50	3.54
<b>3" x 1/32" x 1/4"</b> Max RPM 35,000	051144-82238-6	50/50	4.57
<b>3" x 1/32" x 3/8"</b> Max RPM 35,000	051131-01989-8	5 wheels/pack 10 packs/case	22.88/ pack
	051131-01985-0	50/50	4.57
<b>3" x 1/16" x 3/8"</b> Max RPM 28,000	051131-01990-4	5 wheels/pack 10 packs/case	22.88/ pack
	051131-01986-7	50/50	4.57
<b>4" x 1/16" x 3/8"</b> Max RPM 21,000	051144-83488-4	50/50	5.33
<b>4" x 1/32" x 1/4"</b> Max RPM 26,250	051144-88755-2	50/50	4.74
<b>4" x 1/32" x 3/8"</b> Max RPM 26,250	051131-01994-2	50/50	5.33

Wheels  
Cut-Off



213792

# ■ Specialty Products

## Bench Area Products

### Scotch-Brite™ Radial Bristle Brushes

Excellent replacement for wire brushes. Use on bench motors for general purpose cleaning applications.

- No flying wires yet higher cut rates
- Very strong and flexible
- Comes complete with adapters for multiple shaft sizes (1/2", 5/8", 3/4", 7/8", 1" and 2")

Grade: 36 – Dark Brown  
50 – Green  
80 – Yellow



159129

Dia x Width	Grade	UPC	Qty./Case	List Price
6" x 1/2" Max RPM 10,000	36	048011-27603-8	5	31.33
	50	048011-27605-2	5	31.33
	80	048011-27606-9	5	31.33

### Scotch-Brite™ Stars

Perfect choice for polishing internal diameters of pipe and tubing. Conformable Scotch-Brite™ construction assures complete cleaning and polishing of all surfaces.



51751

Dia	Grade	UPC	Qty./Case	List Price
1 1/2" Max RPM 24,000	A VFN	048011-13800-8	100	1.98
	A CRS	048011-13370-6	100	1.98
2" Max RPM 24,000	A VFN	048011-13803-9	100	2.49
	A CRS	048011-13371-3	100	2.49
3" Max RPM 18,000	A VFN	048011-13802-2	50	3.99
	A CRS	048011-13372-0	50	3.99
4" Max RPM 18,000	A VFN	048011-13804-6	50	6.11
	A CRS	048011-13373-7	50	6.11

## Accessories — Scotch-Brite™ Stars

### Mandrel No. 944

Use in conjunction with Scotch-Brite™ Stars for cleaning and polishing internal diameters of pipe and tubing.



51746

Size	UPC	Qty./Case	List Price
1/4" shank with 1/4"-20 external thread Max RPM 25,100	048011-13928-9	1	4.90



163159

## Bench Area Products (cont.)

### Scotch-Brite™ Flap Brush CPFB-R and CPFB-S

Heavy-duty brush, excellent for removing handling marks and surface imperfections. Available on 1/4" shaft (CPFB-S) or 3M™ Roloc™+ attachment system (CPFB-R).

Dia x W x Shaft	Grade	UPC	Qty./Case	List Price
<b>2" x 1" x 1/4"</b> CPFB-S Max RPM 12,000	A MED	048011-16622-3	25	13.88
<b>3" x 1 3/8"</b> CPFB-R Max RPM 8,000	A MED	048011-14588-4	10	16.06
<b>3" x 1 3/4" x 1/4"</b> CPFB-S Max RPM 8,500	A MED	048011-05974-7	10	21.44



51748

Specialty Products  
Bench Area

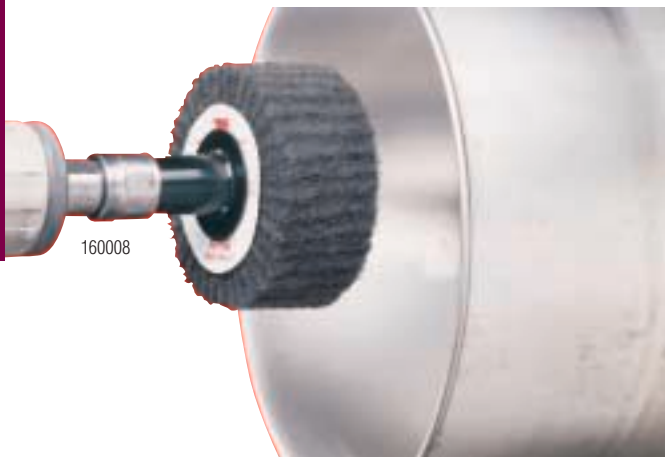

### Scotch-Brite™ Flap Brush CFFB-R and CFFB-S

Ideal for decorative finishes and light deburring applications. Available on 1/4" shaft (CFFB-S) or Roloc™+ attachment system (CFFB-R).

Dia x W x Shaft	Grade	UPC	Qty./Case	List Price
<b>3" x 1 3/8"</b> CFFB-R Max RPM 8,000	A CRS	048011-14587-7	10	16.09
	S FIN	048011-14783-3	10	16.06
<b>3" x 1 3/4" x 1/4"</b> CFFB-S Max RPM 8,500	A CRS	048011-05975-4	10	21.44
	S FIN	048011-14781-9	10	21.44



51752

### Scotch-Brite™ Combi Wheel, Combi-S

Wheels are made of alternating flaps of coated abrasive and Scotch-Brite™ web. Provide aggressive cut and fine finishes.

Dia x W x Shaft	Grade	UPC	Qty./Case	List Price
<b>3" x 1 3/4" x 1/4"</b> Max RPM 8,000	80	051144-80801-4	10	24.26
	P120	051144-80678-2	10	24.26
	P180	051144-80799-4	10	24.26

## Bench Area Products (cont.)

### Scotch-Brite™ Clean & Strip Discs CSD1-R and CSD2-S

Aggressive web is excellent for cleaning welds, rust, paint and coatings.



51747

Dia x W x Shaft	Grade	UPC	Qty./Case	List Price
4" x 1" x 1/4"	S XCS	048011-14780-2	10	15.38
CSD2-S Max RPM 8,000				



14461



159131

### Scotch-Brite™ CPD5-R and CPD5-S

Five discs made of a durable web, ganged together on a shaft. Use for satin or antique finishing as well as light- to medium-duty cleaning applications. Choose from two attachment systems, either 3M™ Roloc™+ or a 1/4" spindle mount.

Dia x W x Shaft	Grade	UPC	Qty./Case	List Price
3" x 1 1/4"	A MED	048011-14594-5	10	9.85
CPD5-R Max RPM 10,000				
4" x 1 1/4"	A MED	048011-14590-7	10	13.76
CPD5-R Max RPM 8,000				
3" x 1 1/4" x 1/4"	A MED	048011-14593-8	10	9.85
CPD5-S Max RPM 10,000				
4" x 1 1/4" x 1/4"	A MED	048011-14779-6	10	13.76
CPD5-S Max RPM 8,000				

## Accessories — Bench Area Products

### 3M™ Roloc™+ Holder No. 1

Use with 3M™ Roloc™+ products.

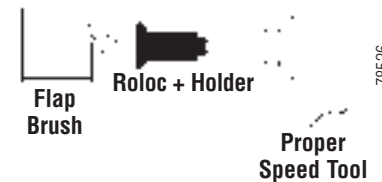

78526

L x Dia	UPC	Qty./Case	List Price
1" x 1/4"	048011-15408-4	5	11.35

# 3M™ Cartridge Rolls

## 241D

(Aluminum Oxide – X wt. Cloth)

General purpose cartridge rolls.

Dia x L x CH	Grade	UPC	Qty./Case	List Price
1/4" x 1" x 1/8" Regular Max RPM 24,000	P60	051144-96959-3	100	0.25
	P80	051144-14021-3	100	0.25
	P120	051144-96961-6	100	0.25
	P180	051144-96963-0	100	0.25
1/4" x 1 1/2" x 1/8" Regular Max RPM 24,000	P60	051144-96968-5	100	0.29
	P80	051144-96969-2	100	0.29
	P120	051144-96971-5	100	0.29
	P180	051144-96973-9	100	0.29
3/8" x 1" x 1/8" Regular Max RPM 24,000	P60	051144-14024-4	100	0.27
	P80	051144-14023-7	100	0.27
	P120	051144-14022-0	100	0.27
	P180	051144-97008-7	100	0.27
3/8" x 1 1/2" x 1/8" Regular Max RPM 24,000	P60	051144-97013-1	100	0.35
	P120	051144-97015-5	100	0.35
	P180	051144-97017-9	100	0.35
1/2" x 1" x 1/8" Regular Max RPM 24,000	P60	051144-97041-4	100	0.29
	P80	051144-97042-1	100	0.29
	P120	051144-97044-5	100	0.29
	P180	051144-97046-9	100	0.29
1/2" x 1 1/2" x 1/8" Regular Max RPM 24,000	P60	051144-14028-2	100	0.40
	P80	051144-14027-5	100	0.40
	P120	051144-14026-8	100	0.40
	P180	051144-97059-9	100	0.40
3/4" x 1 1/2" x 3/16" Regular Max RPM 16,000	P60	051144-97162-6	100	0.56
	P80	051144-97163-3	100	0.56
	P120	051144-97165-7	100	0.56
	P180	051144-97166-4	100	0.56
3/8" x 1" x 1/8" Full Taper Max RPM 24,000	P60	051144-97239-5	100	0.54
	P80	051144-97240-1	100	0.54
	P120	051144-97242-5	100	0.54
	P180	051144-97244-9	100	0.54
3/8" x 1 1/2" x 1/8" Full Taper Max RPM 24,000	P60	051144-97248-7	100	0.58
	P80	051144-97249-4	100	0.58
	P120	051144-97251-7	100	0.58
1/2" x 1" x 1/8" Full Taper Max RPM 24,000	P60	051144-97257-9	100	0.54
	P120	051144-97259-3	100	0.54
1/2" x 1 1/2" x 1/8" Full Taper Max RPM 24,000	P60	051144-14034-3	100	0.56
	P80	051144-14033-6	100	0.56
	P120	051144-14032-9	100	0.56
	P180	051144-97267-8	100	0.56



51754



## 3M™ Cartridge Rolls (cont.)

### 747D

(3M™ Cubitron™ Abrasive Grain – X wt. Cloth)

Regalite resin bond cloth for heat resistance. Features grinding aid for cooler grinding.



14378

Dia x L x CH	Grade	UPC	Qty./Case	List Price
1/2" x 1 1/2" x 1/8" Regular	60	051144-80790-1	100	0.63
	80	051144-80796-3	100	0.63
	P120	051144-80792-5	100	0.63
1/2" x 1 1/2" x 1/8" Full Taper	60	051144-80786-4	100	0.91
	80	051144-80787-1	100	0.91
	P120	051144-80788-8	100	0.91

## Accessories — Cartridge Rolls

### 3M™ Mandrels

Screw-type mandrels for securing cartridge rolls to tool.



51755

Pilot Dia x Pilot Length x Shank	UPC	Qty./Case	List Price
1/8" x 1" x 1/4"	051144-45119-7	1	4.12
3/16" x 1" x 1/4"	051144-45117-3	1	5.53
3/16" x 1 1/2" x 1/4"	051144-45118-0	1	6.07

### Maximum Operating RPMs:

1/2" and smaller cartridge roll dia. – 24,000

5/8" – 3/4" cartridge roll dia. – 16,000

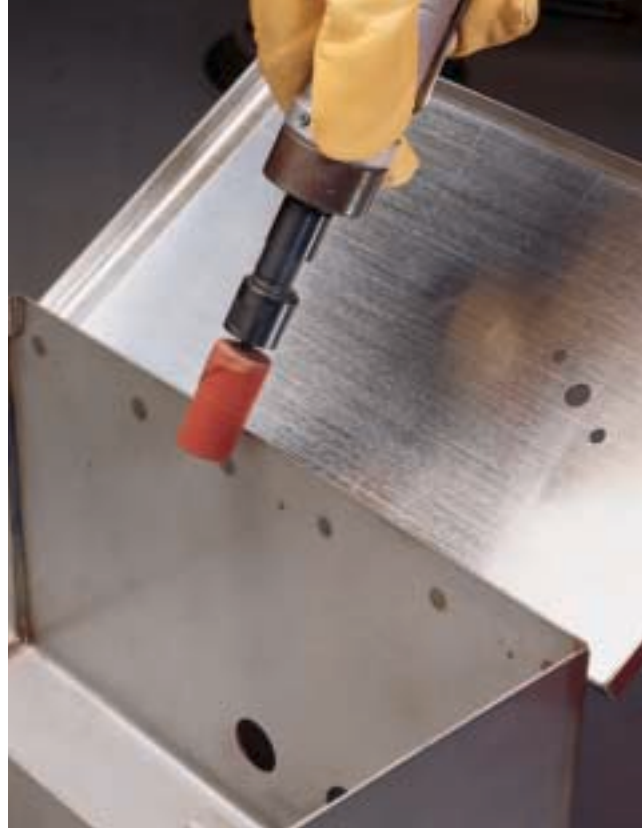

14379

# 3M™ Evenrun Bands

## 241D

(Aluminum Oxide – X wt. Cloth)  
General purpose evenrun bands.

Dia x WD	Grade	UPC	Qty./Case	List Price
1/4" x 1/2" Max RPM 23,000	P60	051144-97426-9	100	0.22
	P80	051144-40243-4	100	0.22
	P120	051144-97428-3	100	0.22
1/2" x 1/2" Max RPM 30,000	P36	051144-97451-1	100	0.23
	P60	051144-40228-1	100	0.23
	P80	051144-40227-4	100	0.23
	P120	051144-40252-6	100	0.23
1/2" x 1" Max RPM 15,000	P36	051144-97458-0	100	0.25
	P60	051144-40225-0	100	0.24
	P80	051144-40224-3	100	0.24
	P120	051144-11973-8	100	0.24
1/2" x 1 1/2" Max RPM 15,000	P36	051144-97464-1	100	0.27
	P60	051144-97467-2	100	0.26
	P80	051144-97468-9	100	0.26
	P120	051144-97470-2	100	0.26
3/4" x 1" Max RPM 17,000	P36	051144-11976-9	100	0.26
	P60	051144-40221-2	100	0.25
	P80	051144-40220-5	100	0.25
	P120	051144-40219-9	100	0.25
3/4" x 1 1/2" Max RPM 10,000	P36	051144-11977-6	100	0.30
	P60	051144-11978-3	100	0.28
	P80	051144-40241-0	100	0.28
	P120	051144-97511-2	100	0.27
1" x 1" Max RPM 18,000	P36	051144-40214-4	100	0.27
	P60	051144-40211-3	100	0.26
	P80	051144-40210-6	100	0.26
	P120	051144-40208-3	100	0.25
1" x 1 1/2" Max RPM 10,000	P36	051144-40207-6	100	0.32
	P60	051144-11980-6	100	0.30
	P80	051144-40205-2	100	0.30
	P120	051144-11981-3	100	0.29
1 1/2" x 1" Max RPM 14,000	P36	051144-40203-8	100	0.29
	P60	051144-40202-1	100	0.27
	P80	051144-40201-4	100	0.27
	P120	051144-97571-6	100	0.26
1 1/2" x 1 1/2" Max RPM 10,000	P36	051144-40200-7	100	0.35
	P60	051144-40197-0	100	0.32
	P80	051144-40196-3	100	0.32
	P120	051144-40274-8	100	0.31
1 1/2" x 2" Max RPM 8,000	P60	051144-40267-0	100	0.43
	P80	051144-40270-0	100	0.42
2" x 1" Max RPM 12,000	P36	051144-40193-2	100	0.32
	P60	051144-40192-5	100	0.30
	P80	051144-11990-5	100	0.30
	P120	051144-11991-2	100	0.29
2" x 2" Max RPM 6,000	P36	051144-40187-1	100	0.53
	P60	051144-40184-0	100	0.48
	P80	051144-40183-3	100	0.47
	P120	051144-11994-3	100	0.46
3" x 3" Max RPM 3,000	P36	051144-40178-9	50	0.92
	P60	051144-40175-8	50	0.84
	P80	051144-40174-1	50	0.80
	P120	051144-40172-7	50	0.79



51756

## 747D

(3M™ Regalite™ Polycut™  
RB Cloth – X wt.)



14420

Dia x WD	Grade	UPC	Qty./Case	List Price
1/2" x 1" Max RPM 15,000	50	051144-80765-9	100	0.41
	60	051144-80769-7	100	0.41
	80	051144-80773-4	100	0.41
1" x 1" Max RPM 18,000	50	051144-80766-6	100	0.46
	60	051144-80770-3	100	0.46
	80	051144-80774-1	100	0.46
	P120	051144-80782-6	100	0.45
	60	051144-80771-0	100	0.52
2" x 1" Max RPM 11,000	80	051144-80775-8	100	0.52
	P120	051144-80783-3	100	0.51

# Accessories — Evenrun Bands

## Rubber Slotted Expander Wheels

Slotted wheels for use with evenrun bands.

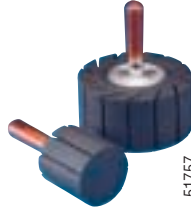

51757

Dia x W x Shaft	UPC	Qty./Case	List Price
1" x 1" x 1/4"	051144-77717-4	1	40.33
1 1/2" x 1" x 1/4"	051144-77718-1	1	45.55
2" x 1" x 1/4"	051144-77720-4	1	50.82
2" x 2" x 1/4"	051144-77721-1	1	52.57
3" x 3" x 5/8" —INT	051144-77722-8	1	150.82

### Maximum Operating RPMs:

1/2" x 1"	— 15,000
1" x 1"	— 18,000
1 1/2" x 1"	— 14,000
2" x 1"	— 12,000
2" x 2"	— 6,000
3" x 3"	— 6,000



51758

## Rubber Cushion Polishing Wheels

Use with evenrun bands when creating fine finishes.



Dia x W x Shaft	UPC	Min./Case	List Price
1/4" x 1/2" x 1/8"	051144-45159-3	1	4.89
1/2" x 1/2" x 1/4"	051144-45156-2	1	6.93
1/2" x 1" x 1/4"	051144-45153-1	1	6.93
1/2" x 1 1/2" x 1/4"	051144-45152-4	1	8.75
3/4" x 1" x 1/4"	051144-45145-6	1	8.75
3/4" x 1 1/2" x 1/4"	051144-45144-9	1	8.75
1" x 1" x 1/4"	051144-45139-5	1	6.93
1" x 1 1/2" x 1/4"	051144-45138-8	1	8.80
1 1/2" x 1" x 1/4"	051144-45132-6	1	7.78
1 1/2" x 1 1/2" x 1/4"	051144-45131-9	1	10.07
1 1/2" x 2" x 1/4"	051144-45130-2	1	14.91
2" x 1" x 1/4"	051144-45129-6	1	10.07
2" x 2" x 1/4"	051144-45127-2	1	20.13
3" x 3" x 3/8"	051144-45124-1	1	62.36
3" x 3" x 1/2"	051144-45123-4	1	62.36

### Maximum Operating RPMs:

1/4" x 1/2" x 1/8"	— 23,000	1 1/2" x 1" x 1/4"	— 14,000
1/2" x 1/2" x 1/4"	— 30,000	1 1/2" x 1 1/2" x 1/4"	— 10,000
1/2" x 1" x 1/4"	— 15,000	1 1/2" x 2" x 1/4"	— 8,000
1/2" x 1 1/2" x 1/4"	— 15,000	2" x 1" x 1/4"	— 11,000
3/4" x 1" x 1/4"	— 17,000	2" x 2" x 1/4"	— 6,000
3/4" x 1 1/2" x 1/4"	— 10,000	3" x 3" x 3/8"	— 3,000
1" x 1" x 1/4"	— 18,000	3" x 3" x 1/2"	— 3,000
1" x 1 1/2" x 1/4"	— 10,000		

\* Part numbers apply to complete wheel, not cushions.

# Hand Sanding Products

## 3M™ Utility Cloth Sheets and Rolls

### 304D

(Aluminum Oxide – X wt. Cloth)

- Constructed on a durable cloth backing
- Ideal for all utility jobs
- Can be torn into strips and rolled without shelling



W x L	Grade	UPC	Min./Case	List Price	
<b>Sheets</b>					
<b>9" x 11"</b>	P40	051111-60332-1	50/250	1.26	
	P50	051111-60333-8	50/250	1.18	
	P60	051111-60334-5	50/250	1.10	
	P80	051111-60342-0	50/250	0.91	
	P100	051111-60343-7	50/250	0.86	
	P120	051111-60344-4	50/250	0.86	
	P150	051111-60345-1	50/250	0.86	
	P180	051111-60346-8	50/250	0.86	
	P220	051111-60347-5	50/250	0.86	
	P240	051111-60348-2	50/250	0.86	
	P280	051111-60349-9	50/250	0.86	
	P320	051111-60350-5	50/250	0.86	
	P400	051111-60352-9	50/250	0.86	
	<b>Utility Rolls</b>				
	<b>1" x 50 yds.</b>	P50	051111-60326-0	1/5	25.99
		P60	051111-60325-3	1/5	24.28
P80		051111-60686-5	1/5	20.52	
P100		051111-60687-2	1/5	19.84	
P120		051111-60688-9	1/5	19.84	
P150		051111-60689-6	1/5	19.84	
P180		051111-60690-2	1/5	19.84	
P220		051111-60691-9	1/5	19.84	
P240		051111-60692-6	1/5	19.84	
P280		051111-60693-3	1/5	19.84	
P320		051111-60694-0	1/5	19.84	
P400		051111-60696-4	1/5	19.84	
<b>1½" x 50 yds.</b>	P50	051111-60327-7	1/5	36.25	
	P60	051111-60328-4	1/5	34.20	
	P80	051111-60697-1	1/5	28.73	
	P100	051111-60698-8	1/5	27.70	
	P120	051111-60699-5	1/5	27.70	
	P150	051111-60700-8	1/5	27.70	
	P180	051111-60701-5	1/5	27.70	
	P220	051111-60702-2	1/5	27.70	
	P240	051111-60703-9	1/5	27.70	
	P280	051111-60704-6	1/5	27.70	
	P320	051111-60705-3	1/5	27.70	
	P400	051111-60707-7	1/5	27.70	
<b>2" x 50 yds.</b>	P40	051111-60329-1	1/5	49.59	
	P50	051111-60330-7	1/5	46.85	
	P60	051111-60331-4	1/5	44.12	
	P80	051111-60708-4	1/5	36.94	
	P100	051111-60709-1	1/5	35.23	
	P120	051111-60710-7	1/5	35.23	
	P150	051111-60711-4	1/5	35.23	
	P180	051111-60712-1	1/5	35.23	
	P220	051111-60713-8	1/5	35.23	
	P240	051111-60714-5	1/5	35.23	
	P280	051111-60715-2	1/5	35.23	
	P320	051111-60716-9	1/5	35.23	
P400	051111-60718-3	1/5	35.23		

### 211K

(Grades 320–500)

(Aluminum Oxide – J wt. Cloth)

Use these flexible utility rolls and sheets for general applications such as deburring, rust removal, strapping and all general maintenance work.

W x L	Grade	UPC	Min./Case	List Price
<b>Sheets</b>				
<b>9" x 11"</b> 211K	320	051144-02402-5	50/250	1.25
	400	051144-12501-2	50/250	1.25
	500	051144-12500-5	50/250	1.25
<b>Utility Rolls</b>				
<b>1" x 50 Yds</b> 211K	320	051144-05002-4	1/5	29.51
	400	051144-05001-7	1/5	29.51
	500	051144-05000-0	1/5	29.51
<b>1½" x 50 Yds</b> 211K	320	051144-05022-2	1/5	41.21
	400	051144-05021-5	1/5	41.21
	500	051144-05020-8	1/5	41.21
<b>2" x 50 Yds</b> 211K	320	051144-05042-0	1/5	52.41
	400	051144-05041-3	1/5	52.41
	500	051144-05040-6	1/5	52.41

### 011K

(Emery Cloth – Closed Coat)

- General purpose use



W x L	Grade	UPC	Min./Case	List Price
<b>9" x 11"</b> 011K	CRS	051144-02433-9	50/250	1.31
	MED	051144-02432-2	50/250	1.20
	FINE	051144-02431-5	50/250	1.15

## Accessories — Utility Rolls

### Forked Spindle

Forked spindle for attaching utility cloth strips.



Dia x L	UPC	Qty./Case	List Price
<b>¼" x 3"</b>	051144-45121-0	1	6.88

# 3M™ Wetordry™ Sheets

3M™ Wetordry™ construction reduces clogging, eliminates dust, extends abrasive life and improves finish.

## 431Q

(Silicon Carbide – C wt. Paper)

- Heavyweight paper backing for increased durability



## 413Q

(Silicon Carbide – A wt. Paper)

- Excellent conformability



W x L	Grade	UPC	Min./Case	List Price
9" x 11" 431Q	80	051144-02018-8	50/250	1.11
	100	051144-02017-1	50/250	0.97
	120	051144-02016-4	50/250	0.84
	150	051144-02015-7	50/250	0.79
9" x 11" 413Q	180	051144-02014-0	50/250	0.74
	220	051144-02007-2	50/500	0.67
	240	051144-02006-5	50/250	0.67
	280	051144-02005-8	50/250	0.67
	320	051144-02004-1	50/500	0.67
	360	051144-02003-4	50/250	0.67
	400	051144-02002-7	50/500	0.67

# 3M™ Paper Sheets

## 346U

(Aluminum Oxide – D wt. Paper)

This is ideal for hand or machine sanding of many different materials, including woods, metals, paints, plastics and fiberglass.



## 336U

(Aluminum Oxide – C wt. Paper)

Medium-weight sheets for general-purpose sanding.

Open coat resists loading on soft materials.



## 210N

(Aluminum Oxide – A wt. Paper)

(Open Coat)

Provides exceptional conformability for contour sanding.

W x L	Grade	UPC	Min./Case	List Price
9" x 11" 346U	36	051144-02119-2	50/250	0.94
	40	051144-02118-5	50/250	0.84
	50	051144-02117-8	50/500	0.74
	60	051144-02116-1	50/500	0.65
	80	051144-02115-4	50/500	0.56
9" x 11" 336U	100	051144-02114-7	100/1000	0.50
	120	051144-02113-0	100/1000	0.50
	150	051144-02112-3	100/1000	0.50
9" x 11" 210N	180	051144-02104-8	100/1000	0.34
	220	051144-02103-1	100/1000	0.34

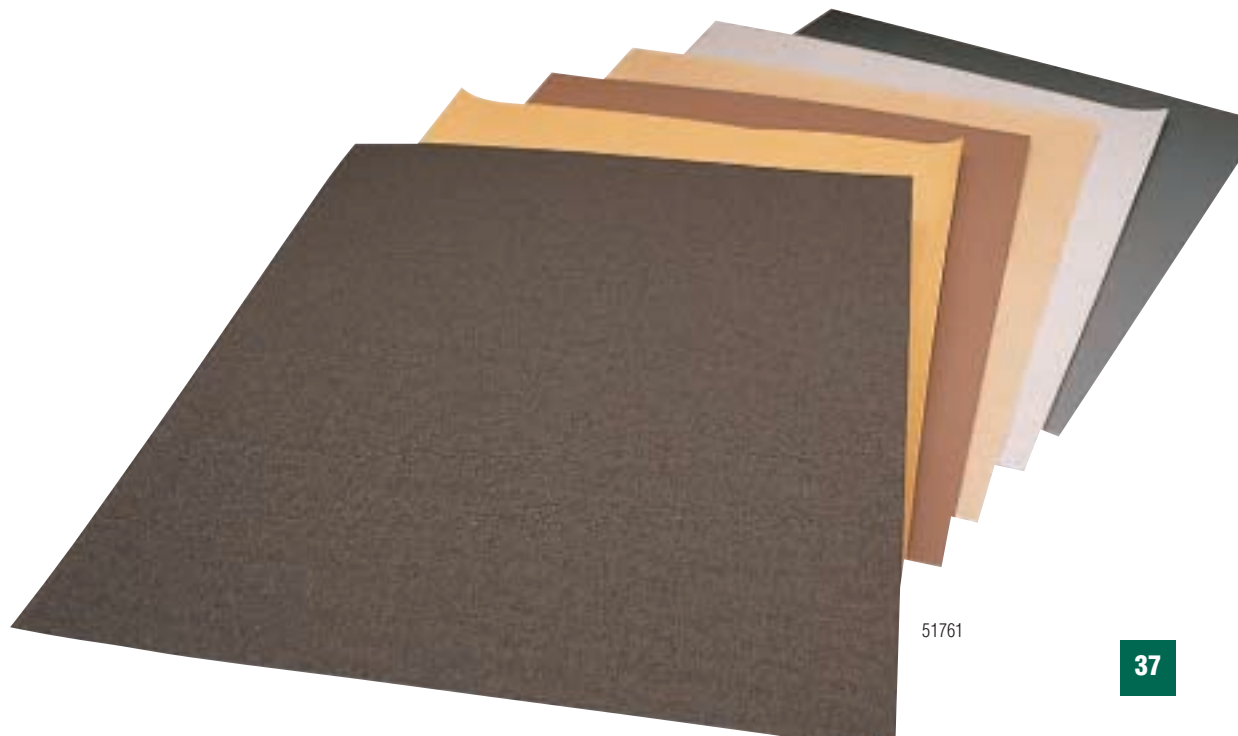

# Hand Pads

## Scotch-Brite™ Hand Pads

Excellent products for hand finishing and cleaning of woods, metals and composites. Ideal for:

- Wood finishing
- Paint prep
- General cleaning



163337

W x L	Cat. No.	Color/Grade	UPC	Qty./Case	List Price
6" x 9"	7440	Tan A MED	048011-04050-9	40	103.08
6" x 9"	7446	Gray S MED	048011-04051-6	40	69.39
6" x 9"	7447	Maroon A VFN	048011-04029-5	60	57.44
6" x 9"	7448	Light Gray S ULF	048011-04028-8	60	57.44



51762

## Accessories — Hand Pads

### Scotch-Brite™ Pad Holder No. 961

Use with Scotch-Brite™ hand pads or roll material cut to 4" x 6". Provides increased leverage and eliminates "finger" marks.



51766

W x L	UPC	Min./Case	List Price
3½" x 4¾"	048011-09493-4	10	45.15/Case

## Rolls

### Scotch-Brite™ Cut & Polish Rolls

• Heavy duty wheels for aggressive blending and finishing  
Long-lasting and aggressive, Cut & Polish wheels perform well on all kinds of tough blending and finishing jobs. They produce uniform results quickly and easily and are often used to replace conventional abrasives such as rubber bonded wheels, set-up wheels, abrasive flap wheels and belts.

W x L	Grade	UPC	Qty./Case	List Price
1" x 30"	A MED	048011-04085-1	12	30.11
2" x 30"	A MED	048011-05206-9	6	56.29
4" x 30"	A MED	048011-05207-6	3	112.58



51762

### Scotch-Brite™ Clean & Finish Rolls

Highly conformable Scotch-Brite™ web can be cut to desired length for hand sanding or oscillating sanders.

W x L	Grade	UPC	Min./Case	List Price
4" x 30'	A MED	048011-00264-4	1/3	69.60
	A FIN	048011-00265-1	1/3	51.60
	A VFN	048011-00266-8	1/3	43.20
	S VFN	048011-00270-5	1/3	43.20
6" x 30'	A MED	048011-00274-3	1/2	100.80
	A FIN	048011-00275-0	1/2	75.60
	A VFN	048011-00276-7	1/2	63.00



51764

### Scotch-Brite™ Multi-Flex Sheet Rolls

Highly conformable Scotch-Brite™ webs perforated on a roll. Excellent sharpness and conformability for cleaning and finishing surfaces by hand.

W x L	Color/Grade	UPC	Min./Case	List Price
8" x 4" Sheets 60 Sheets/Roll	Maroon A VFN	051131-07521-4	1/4	34.92/Roll
	Light gray S ULF	051131-07522-1	1/4	34.92/Roll



51768

## Accessories —

### Rolls

#### Mini Mandrel No. 935

Use with desired Scotch-Brite™ strips to clean and polish I.D.'s and other tight areas. Mandrel has a 1/4" shank to fit desired tool.

L x Dia	UPC	Qty./Case	List Price
2 7/8" x 1/4" Max RPM 14,000	048011-04020-2	5	17.45

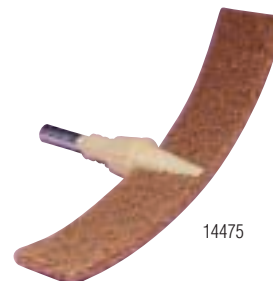

14475

# 3M™ Intro Kits

An easy way to evaluate the right product, size and grade for your application.

## Scotch-Brite™ Surface Conditioning Disc Pack 920S

Introductory pack containing a variety of grades of 2" and 3" non-woven surface conditioning discs. Used for cleaning, finishing, blending and deburring applications. Also includes 922 and 923 disc pad holder.



312784

Size	UPC	Min./Case	List Price
2" & 3"	048011-18253-7	1/5	52.24

## 3M™ Roloc™ Bristle Disc Pack 983BS

Convenient introductory pack containing a variety of grades of Roloc™ Bristle Discs 3" diameter x 5/8" trim. Also includes a disc pad holder.



14374

Size	UPC	Min./Case	List Price
3"	048011-18697-9	1/5	93.70

## Scotch-Brite™ Surface Conditioning Disc Pack 914S

Introductory pack containing a variety of grades of 4" non-woven surface conditioning discs. Used for cleaning, finishing, blending and deburring applications. Also includes 914 disc pad holder.



312740

Size	UPC	Min./Case	List Price
4"	048011-08707-8	1/5	40.00

## Scotch-Brite™ Surface Conditioning Disc Pack 9145S

Introductory pack containing a variety of grades of 4 1/2" non-woven surface conditioning discs. Used for cleaning, finishing, blending and deburring applications. Also includes 9145 disc pad holder.



312741

Size	UPC	Min./Case	List Price
4 1/2" Max RPM 13,000	048011-14105-3	1/5	40.00

## Scotch-Brite™ Surface Conditioning Disc Pack 915S

Introductory pack containing a variety of grades of 5" non-woven surface conditioning discs. Used for cleaning, finishing, blending and deburring applications. Also includes 915 disc pad holder.



312742

Size	UPC	Min./Case	List Price
5" Max RPM 10,000	048011-08713-9	1/5	40.00

## Scotch-Brite™ Surface Conditioning Disc Pack 917S

Introductory pack containing a variety of grades of 7" non-woven surface conditioning discs. Used for cleaning, finishing, blending and deburring applications. Also includes 917 disc pad holder.



312739

Size	UPC	Min./Case	List Price
7" Max RPM 6,000	048011-04270-1	1/5	63.48





## 3M™ Intro Kits (cont.)

### 3M™ Roloc™ Disc Pack 9815S

Convenient introductory pack includes 1½" diameter Roloc™ surface conditioning discs, 3M™ coated abrasive discs and Roloc™ disc pad.



312748

Size	UPC	Min./Case	List Price
1½"	051144-82901-9	1/5	31.84

### 3M™ Roloc™ Disc Pack 982S

Convenient introductory pack includes 2" diameter Roloc™ surface conditioning discs, 3M™ coated abrasive discs and Roloc™ disc pad.



312746

Size	UPC	Min./Case	List Price
2"	051144-82899-9	1/5	38.28

### 3M™ Roloc™ Disc Pack 983S

Convenient introductory pack includes 3" diameter Roloc™ surface conditioning discs, 3M™ coated abrasive discs and Roloc™ disc pad.



312747

Size	UPC	Min./Case	List Price
3"	051144-82900-2	1/5	51.29

### 3M™ Roloc™ Disc Pack 984WS

Convenient introductory pack includes 4" diameter Roloc™ surface conditioning discs, 3M™ coated abrasive discs and Roloc™ surface conditioning discs.



312745

Size	UPC	Min./Case	List Price
4"	051144-83490-7	1/5	48.87

### 3M™ Roloc™ Disc Pack 985S

A convenient introductory pack containing a variety of grades of 2" and 3" non-woven Roloc™ surface conditioning discs. Also contains 2" and 3" disc pads and ¼" threaded shaft.



312743

Size	UPC	Min./Case	List Price
2" & 3"	048011-18254-4	1/5	50.17

### Scotch-Brite™ Unitized Wheel Pack 990S

A convenient introductory pack containing several Scotch-Brite™ external Unitized Wheels 1" x 1" x ⅜" and 3" x ¼" x ⅜" in a variety of densities and grades. Also includes 936 and 990 mandrels.

Size	UPC	Min./Case	List Price
1" x 1" x ⅜", 3" x ¼" x ⅜"	048011-18245-2	1/5	57.78

### 3M™ NTN Maintenance and Repair Kit

Variety of easy mounting (no mounting tools required) coated and surface conditioning 4½" discs for use on right angle tools. Components:

- 1 – 3M™ TN Disc Pad
- 1 – Scotch-Brite™ RS Disc, TN
- 1 – Scotch-Brite™ Clean and Strip XT Disc, TN
- 1 – 3M™ Fibre Disc 785C, TN
- 1 – 3M™ Flap Disc 747D, TN.



291769

Size	UPC	Min./Case	List Price
4½"	048011-33013-6	1/5	29.99



291768

# Machine/Product Chart

Page #	Machine/Product	Grinding	Blending	Finishing	Deburring	Cleaning	Cutting
<b>Right Angled Grinder</b>							
4	3M™ 281C Fibre Disc	●					
4	3M™ 501C Fibre Disc	●					
5	3M™ 785C Fibre Disc	●					
5	3M™ 985C Fibre Disc	●					
4	3M™ 988C Fibre Disc	●					
7	Flexible Grinding Wheel	●					
7	Depressed Center Wheel	●					
8	3M™ 563D Flap Disc	●	●				
8	3M™ 747D Flap Disc	●	●				
15	Scotch-Brite™ Surface Conditioning Disc		●	●			
16	Scotch-Brite™ Coatings Removal Disc					●	
<b>Right Angled Die-Grinder</b>							
9	3M™ Roloc™ Disc 361F	●	●				
10	3M™ Roloc™ Disc 461F	●	●				
10	3M™ Roloc™ Disc 777F	●	●				
10	3M™ Roloc™ Disc 963G	●	●				
10	3M™ Roloc™ Disc 977F	●	●				
11	3M™ Roloc™ Fibre Disc 501C	●	●				
11	3M™ Roloc™ Fibre Disc 785C	●	●				
11	3M™ Roloc™ Fibre Disc 983C/988C	●	●				
12	Scotch-Brite™ Roloc™ Surface Conditioning Disc		●	●	●	●	
12	Scotch-Brite™ Roloc™ Bristle Discs					●	
25	Scotch-Brite™ Roloc™ EXL Unitized Wheel				●		
<b>Random Orbital/Dual Action Sander</b>							
15	Scotch-Brite™ Surface Conditioning Disc (Hook-and-Loop)			●	●	●	
17	3M™ Stikit™ Disc Roll 236U		●	●			
17	3M™ Stikit™ Disc Roll 363I		●	●			
17	3M™ Stikit™ Disc Roll 763U		●				
17	3M™ PSA Disc Roll 316U		●	●			
18	3M™ Stikit™ Disc Roll 241D		●				
18	3M™ Stikit™ Disc 300D		●				
19	3M™ PSA Disc 248D	●	●				
19	3M™ PSA Disc 778F	●	●				
<b>File Belt Tool</b>							
20	3M™ 241D Belt	●	●				
20	3M™ 241E/251E Belt	●					
20	3M™ 777F Belt	●	●		●		
20	3M™ Trizact™ CF Belt		●	●			
24	Scotch-Brite™ Surface Conditioning Belt		●	●	●	●	
<b>Belt Machine</b>							
21	3M™ 241D Belt	●	●	●			
21	3M™ 963G Belt	●	●				

## Machine/Product Chart (cont.)

Page #	Machine/Product	Grinding	Blending	Finishing	Deburring	Cleaning	Cutting
<b>Belt Machine (cont.)</b>							
22	3M™ Belts 977F/777F	●	●				
22	3M™ Trizact™ 237AA Belt			●			
23	3M™ Trizact™ 307EA Belt		●	●			
23	3M™ Trizact™ CF Belt		●	●			
24	Scotch-Brite™ Surface Conditioning Belts		●	●	●	●	
<b>Bench Motor Machine</b>							
14	Scotch-Brite™ High Strength Discs			●	●	●	
26	Scotch-Brite™ EXL Deburring Wheels			●	●	●	
26	Scotch-Brite™ Multi-Finishing Wheels			●			
26	Scotch-Brite™ Cut & Polish Wheels		●	●			
27	Flap Wheel 244E/241E/741A		●	●	●		
29	3M™ Radial Bristle Brush			●	●		
<b>Die Grinder</b>							
14	Scotch-Brite™ Clean & Strip Discs					●	
14	Scotch-Brite™ High Strength Discs			●	●	●	
25	Scotch-Brite™ EXL Unitized Wheels				●		
27	3M™ Flap Wheels 747D		●				
27	Mounted Flap Wheel 244E		●				
29	Scotch-Brite™ Stars			●	●	●	
30	Scotch-Brite™ Flap Brush CPF-B-R & CPF-B-S		●	●			
30	Scotch-Brite™ Flap Brush CFF-B-R & CFF-B-S		●	●			
30	Scotch-Brite™ Combi Wheel		●	●			
31	Scotch-Brite™ Clean & Strip Discs CSD1-R & CSD2-S					●	
31	Scotch-Brite™ CPD5-R & CPD5-S		●	●			
32	3M™ 241D Cartridge Rolls		●	●	●		
33	3M™ 747D Cartridge Rolls		●	●	●		
34	3M™ 241D Evenrun Bands	●	●				
34	3M™ 747D Evenrun Bands		●				
<b>Cut-Off Tool</b>							
28	3M™ Green Corps™ Cut-Off Wheels						●
<b>Hand Sanding</b>							
36	3M™ 304D Utility Cloth		●	●		●	
36	3M™ 211K Utility Cloth			●			
36	3M™ 011K Paper Sheets		●	●			
37	3M™ 346U Paper Sheets		●				
37	3M™ 336U Paper Sheets		●				
37	3M™ 210N Paper Sheets			●			
37	3M™ 431Q Paper Sheets		●				
37	3M™ 413Q Paper Sheets			●			
38	Scotch-Brite™ Hand Pads		●	●		●	
39	Scotch-Brite™ Multi-Flex Sheet Rolls		●	●		●	
39	Scotch-Brite™ Clean & Finish Rolls		●	●		●	
39	Scotch-Brite™ Cut & Polish Rolls		●	●		●	

# Grade Comparison Chart

Ind'l Mesh-ANSI	FEPA "P"	Trizact™	Micron	Emery	Grade
12	P12				
	P16				
16	P20				
20	P24				
24					
30	P30				
36	P36			Coarse	
40	P40				
50	P50				
60				Medium	
	P60				
	P80				
80			180		
	P100				
100			150	Fine	Ex Coarse
	P120	A160			
120			120		Coarse
	P150	A130			
150			100		Medium
180	P180		80		
220			60		
	P220	A90			
	P240				
240		A65	50		Fine
	P280				
	P320				
280			40		
	P360				
320					Very Fine
	P400	A45			
	P500				
360					
	P600				
400			30		
	P800	A30			
500					
	P1000		20		
600			15		Super Fine
	P1200		12		
		A16			
800	P2000	A6	9		
	P2500		5		
			4		
1000			3		Ultra Fine
			2		
			1		
1200			0.5		
			0.3		
			0.1		
			0.05		

Chart  
Grade Comparison

1 inch = 25.4 millimeters  
 1 millimeters = 0.039370 inches  
 1 micron ( $\mu$ ) = 0.000039 inches  
 ANSI – American National Standards Institute  
 FEPA – Federation of European Producers of  
 Abrasives Products

**Please Note:** Throughout this catalog, Scotch-Brite™ grades are abbreviated:

ULF	—	Ultra Fine	MED	—	Medium
VFN	—	Very Fine	CRS	—	Coarse
FIN	—	Fine	XCS	—	Extra Coarse

# ■ Adhesives & Tapes

## Adhesive Selection Guide

Metal To:	Structurals		Non-Structurals	
	3M™ Scotch-Weld™ Adhesives	3M™ Jet-Weld™ Adhesives	3M™ Scotch-Grip™ Adhesives	Aerosols
<b>Metal</b>	Epoxies, DP810	—	1357, 1099, 1300	80, 90
<b>EPDM Rubber</b>	—	—	4799	—
<b>Rubber (except EPDM)</b>	Flexible 2-Part Epoxies	TS115, TS230, TE040	1300, 847	80, 90*
<b>Glass &amp; Ceramics</b>	Flexible 2-Part Epoxies	—	1357	80, 90
<b>Plastics (Polyolefins)</b>	DP8010**	—	4693	90
<b>Plastics (ABS, PVC, Acrylic, etc.)</b>	Flexible 2-Part Epoxies	TS115, TS230, TE040	4693, 1357	77, 80, 90
<b>Plastics (High Performance Nylon)</b>	Flexible 2-Part Epoxies, DP420, DP460	—	1099, 4693	77, 80, 90
<b>Plastics (Flexible Vinyl)</b>	Flexible 2-Part Epoxies	—	1099	80
<b>Rigid Foam (Urethane)</b>	—	TS115, TS230, TE040	1357, 5, 10	74, 80

**Note:** The technical information and data on these pages should be considered representative or typical only and should not be used for specification purposes. Final product selection should be made only after consideration of a variety of factors and evaluation of sample bonds.

\* Produces a temporary bond on these materials.

\*\* If greater adhesion is required to bare metal, evaluate DP8005.

## Aerosol Adhesives

### 3M™ FoamFast 74 Spray Adhesive

Adhesive bonds flexible urethane or latex foam together or to wood, metal and plastic. Bonds on contact yet has a 15 minute bonding range. Controlled variable 1" to 3" misting and spray. Gives fast tack with foam tearing strength and a soft, non-dimpling glue line. General upholstery foam bonding, to bond small foam shapes by knife edge bonding, boxing, and edge turning. ORIGINAL FORMULA IS NOT FOR SALE OR USE IN CALIFORNIA.



138977

Size	Description	UPC	Qty./Case	List Price
24 fl. oz.	Orange	021200-82242-1	12	11.81
	Clear	021200-50045-9	12	11.81
	Original Formula Orange	021200-96316-2	12	11.81

### 3M™ Super 77 Multipurpose Adhesive

High coverage, fast tack and a long-bonding range. Versatile — securely bonds most lightweight materials, plus it has low soak-in for long-lasting bonds. Excellent for jobs in display and furniture — it bonds thin decorative film, foils and fabrics. Bonds gaskets in water pumps, and attaches insulation to sheet metal. Attaches wiring diagrams, very versatile adhesive. ORIGINAL FORMULA IS NOT FOR SALE OR USE IN CALIFORNIA.



274371

Size	Description	UPC	Qty./Case	List Price
24 fl. oz.	Original Formula	021200-96315-5	12	10.73
	Low Mist	021200-21210-9	12	10.73

### 3M™ Rubber & Vinyl 80 Spray Adhesive

The first true neoprene contact adhesive. Very strong with a 400 psi shear strength. Sprays right where you want it — up to the edge, not over. Position parts 30 minutes after applying adhesive. Plasticizer and high temperature resistant to 200°F (93°C). Fast drying and fast bonding, a durable, high strength adhesive. Can be used for all types of rubber bonding except EPDM. Bonds most supported vinyl and leather. Adheres stainless steel panels, stiffeners, metal kick plates and most plastics, laminates and wood products.



247179

Size	UPC	Qty./Case	List Price
24 fl. oz.	021200-82618-4	6	15.18

### 3M™ Hi-Strength 90 Spray Adhesive

Great initial strength that builds up to 230 psi shear strength. Excellent for many decorative laminates because it dries in 1 to 2 minutes. Also a great adhesive for particle board, polyethylene, polypropylene and SBR rubber. The variable spray width and precise spray control lets you spray adhesive where you want it. Bonds decorative laminates to tables, cabinets, and shelving, kick plates to desks, and plastic sign lettering to wood. Adheres polyethylene and polypropylene to wood, metal and more



171595

Size	UPC	Qty./Case	List Price
24 fl. oz.	021200-30023-3	12	14.50

# 3M™ Scotch-Grip™ Adhesives

## 3M™ Scotch-Grip™ Contact Adhesive 5

A sprayable contact adhesive for bonding many high pressure plastic laminates to metal and other surfaces. The green version meets the requirements of MIL Spec MMM-A-121.

Size	Color	UPC	Qty./Case	List Price
5 Gallon Pail	Green	021200-21232-1	1	30.14/Gallon
	Neutral	021200-20333-6	1	30.76/Gallon

## 3M™ Scotch-Grip™ Contact Adhesive 10

A brushable, neutral-colored contact adhesive for bonding many decorative laminates, aluminum, steel, plywood, panels, wood and wood veneer, masonry, rubber, canvas and other porous and non-porous materials to each other or to themselves.



Size	Color	UPC	Qty./Case	List Price
Quart	Neutral	021200-20272-8	12	14.98
1 Gallon	Neutral	021200-20274-2	4	45.79
5 Gallon Pail	Neutral	021200-20276-6	1	33.90/Gallon

## 3M™ Scotch-Grip™ High Performance Contact Adhesive 1357

High performance contact adhesive. Provides a long bonding range. Excellent initial strength. Adheres well to many decorative plastic laminates, paper honeycomb, rubber, cloth, metal, wood and foamed glass.



Size	Color	UPC	Qty./Case	List Price
5 oz. Tube	Gray Olive	021200-19887-8	36	8.41
Pint	Gray Olive	021200-19890-8	12	15.11
Quart	Gray Olive	021200-19892-2	12	20.05
1 Gallon	Gray Olive	021200-19894-6	4	61.19
	Neutral	021200-22586-4	4	62.81
5 Gallon Pail	Gray Olive	021200-19897-7	1	44.38/Gallon
	Neutral	021200-64963-9	1	46.72/Gallon

## 3M™ Scotch-Grip™ Rubber and Gasket Adhesive 847, 1300 and 4799

A premium quality, reddish brown, multi-purpose adhesive. Develops strong flexible bonds very rapidly to a wide variety of substrates, including many plastics and rubbers, gasketing materials and leather. Has exceptional resistance to most fuels and oil.



Size	UPC	Qty./Case	List Price
5 oz. Tube 847	021200-19718-5	36	8.38
Quart 847	021200-19721-5	12	25.45
5 oz. Tube 1300	021200-19868-7	36	8.38
5 oz. Tube 4799	021200-21354-0	36	8.38

## 3M™ Scotch-Grip™ Plastic Adhesive 1099

A very strong plastic adhesive which is resistant to weather, fuel, oil, plasticizers and solvents. Bonds most plastic and vinyl. Heat curing boosts overlap shear strength to 388 psi and increases heat resistance from 160° to 250°F. Parts to be bonded can be attached up to 40 minutes after applying adhesive.



Size	UPC	Qty./Case	List Price
5 oz. Tube	021200-19808-3	36	8.38

## 3M™ Scotch-Grip™ Plastic Adhesive 4693H

A clear, elastomeric adhesive with exceptional adhesion to metal and plastic. This adhesive is unique in its ability to bond hard-to-hold materials like polypropylene, polyethylene and high-impact polystyrene. Exhibits high immediate bond strength, long tack range and contact bond properties. Good resistance to water and aging.



Size	UPC	Qty./Case	List Price
5 oz. Tube	021200-30088-2	36	8.15

# Structural Adhesives

## 3M™ Scotch-Weld™ Low Odor Acrylic Adhesive DP810

A very fast curing, toughened two-part adhesive with uncommonly high peel and shear strength on oily steel, aluminum, many plastics, glass and painted surfaces. Has a 10-minute work life and gains handling strength in 20 minutes at room temperature.



123041

Size	Color	UPC	Qty./Case	List Price
1.7 fl. oz.	Clear	021200-31310-3	12	14.05
200ml	Clear	021200-31311-0	12	52.88

## 3M™ Scotch-Weld™ Two-Part Structural Adhesive 2216 B/A

Highly flexible, two-part adhesive kit (2/3 full container of base, 1 full container of accelerator). Cures at room temperature. Provides high strength bonds in shear and peel. Bonds rubber, metal, wood, plastic and masonry.

Size	Color	UPC	Qty./Case	List Price
Quart Kit	Gray	021200-20854-6	6	136.50

## 3M™ Scotch-Weld™ Two-Part Epoxy Adhesive DP420

A very high performance, two-part epoxy adhesive. Great for bonding metal, plastic and wood with outstanding reliability and durability. This product is toughened to provide high peel strength and a shear strength of 4500 psi. Has a 20 to 30 minute work life. Handling strength in 8 to 12 hours.



38696

Size	Color	UPC	Qty./Case	List Price
1.25 fl. oz.	Off-White	021200-82236-0	12	11.90

## 3M™ Scotch-Weld™ Two-Part Epoxy Adhesive DP460

A very high performance epoxy adhesive. Great for bonding a wide variety of materials with outstanding reliability and durability. This product is toughened to provide extremely high peel strength and a shear strength of 4500 psi. Has a 60 to 80 minute work life. Handling strength in 8 to 12 hours. Meets requirements of MIL-A-23941A3.



199262

Size	Color	UPC	Qty./Case	List Price
1.25 fl. oz.	Off-White	021200-82225-4	12	11.90

## 3M™ Scotch-Weld™ Structural Plastic Adhesive DP8010

A 2-part structural acrylic-based adhesive that can structurally bond many low surface energy plastics. Can bond to many grades of polypropylene and thermoplastic elastomers (TPE's) without any surface preparation at room temperature. Has a 10 minute work life. Mix ratio is 10 parts Base to 1 part Accelerator by volume.



189874

Size	UPC	Qty./Case	List Price
35ml	021200-49110-8	12	17.49

## 3M™ Jet-Weld™ Thermoset Adhesive TE040

A one-component, moisture curing urethane adhesive that is applied warm. This low viscosity adhesive has a fast set time and is ideal for bonding most wood, plastics, metal and glass.



128158

Size	UPC	Qty./Case	List Price
10 fl. oz.	021200-25340-9	6	32.20

## 3M™ Jet-Weld™ Thermoset Adhesive TS115 HGS

Applies easily like conventional hot-melt adhesives then cures to give tough, high-strength bonds. Effectively bonds to a wide variety of substrates including wood, fiber reinforced plastics (FRP), and most plastics to themselves and to metal. A sprayable/extrudable grade with medium set time and long open time (10 minutes in bead form) that has medium viscosity. It is commonly used for laminating applications due to its high green strength (HGS).



128158

Size	UPC	Qty./Case	List Price
1/10 Gallon	021200-89449-7	6	34.80

## 3M™ Jet-Weld™ Thermoset Adhesive TS230, Off-White

Applies easily like conventional hot-melt adhesives then cures to give tough, high-strength bonds. Effectively bonds to a wide variety of substrates including wood, fiber reinforced plastics (FRP), and most plastics to themselves and to metal. A sprayable/extrudable grade with long set time, suited especially for bonding a wide variety of plastics including polystyrene and polyacrylic.



128158

Size	UPC	Qty./Case	List Price
1/10 Gallon	021200-83643-5	6	35.02

# 3M™ EPX™ Applicators and Accessories

## 3M™ EPX™ Applicators and Accessories

Mixing nozzle will perform to your requirements. With consistent air pressure for easy uniform application, the Duo-Pak cartridge will give you the flow rate needed. Fast, convenient way to simultaneously meter, mix and apply two-part adhesives and potting compounds. System features handy Duo-Pak Adhesive Cartridges that snap quickly into the durable, lightweight EPX applicator. A slight squeeze on the trigger advances the plunger into the cartridge. Accurate measurement and the mixing nozzle provides thorough mixing and precise placement of material. Ideal system for assembly, maintenance and in-field service.

Size	Description	UPC	Qty./Case	List Price
50ml	EPX Applicator #9470 with Plunger	021200-21789-0	10	44.16
50ml	EPX Pneumatic Applicator	021200-83528-5	1	319.23
50ml	EPX Plus II Applicator with 2:1 and 1:1 Plunger	021200-50004-6	10	44.16
50ml	EPX Mixing Nozzle #9742	021200-21791-3	72	1.23
	EPX 2:1 Plunger Assembly	021200-82314-5	10	4.90



128158

## 3M™ Jet-Weld™ II Adhesive Applicator, Preheater and Accessories

- For improved productivity
- Preheater holds up to four 10 fl. oz. cartridges



8341

Description	UPC	Qty./Case	List Price
Applicator	021200-89463-3	1	800.32
Preheater**	021200-89464-0	1	790.90

To increase productivity, optional tips are available.



8343

Size	Description	UPC	Qty./Case	List Price
.090"	Standard Tip	021200-87191-7	3*	40.66/Bag
.72"	Extension Tip (1.25")**	021200-89471-8	3*	45.60/Bag
.062"	Low Flow Tip**	021200-89472-5	3*	41.05/Bag
.125"	High Flow Tip**	021200-89473-2	3*	41.05/Bag

\* Quantities indicated are tips per bag.

\*\* Non-stock, make to order only.



# 3M™ VHB™ Tapes



For 25 years, engineers have been specifying 3M™ VHB tapes to permanently bond and seal many metals, plastics, and other surfaces for increased productivity, high strength, long term durability and improved appearance.

3M™ VHB Tape’s all-acrylic construction seals against moisture and most solvents, providing long-term resistance to UV and temperature cycles. The tape’s unique foam acts as a shock absorber for outstanding impact resistance. Unlike the stress points common to mechanical fasteners, 3M™ VHB™ tape distributes the stress. You can use thinner, light-weight materials with less material fatigue.

Product #	Color	Temperature Resistance		Applications & Features
		Short	Long	
<b>4941 (45 mils)</b>	Gray	300°F	200°F	Conformable and plasticizer resistant. Good adhesion to metals, plastics and plasticized vinyls.
<b>4611 (45 mils)</b>	Dark Gray	450°F	300°F	Bonds to bare metal and holds parts together during the washes and high temperature bake of a powder paint cycle. Used for hat channel and stiffener attachments.
<b>5952 (45 mils)</b>	Black	300°F	200°F	Bonds to most liquid and powder painted surfaces, and ABS blends, without the need to prime the surface first.
<b>4945 (45 mils)</b>	White	300°F	200°F	Plasticizer resistant. High strength firm core. Bonds to most painted substrates. Good adhesion to substrates containing plasticizers.
<b>4950 (45 mils)</b>	White	300°F	200°F	Bonds to most metals and high surface energy substrates.

**Note:** This technical information and data should be considered representative or typical only, and should not be used for specification purposes.

## VHB™ Tapes

Size	UPC	Quantity Per Case
<b>4941</b>		
½" x 36 yds	021200-64886-1	18
¾" x 36 yds	021200-64887-8	12
1" x 36 yds	021200-64888-5	9
<b>4611</b>		
½" x 36 yds	021200-56375-1	18
¾" x 36 yds	021200-56002-6	12
1" x 36 yds	021200-56146-7	9
<b>5952</b>		
½" x 36 yds	021200-59967-5	18
1" x 36 yds	021200-56229-7	9
<b>4945</b>		
½" x 36 yds	021200-16961-8	18
¾" x 36 yds	021200-16954-0	12
1" x 72 yds	021200-16955-7	9
<b>4950</b>		
½" x 36 yds	021200-18090-3	18
¾" x 36 yds	021200-18091-0	12
1" x 36 yds	021200-18092-7	9



VHB™ Tape Adhesives & Tapes

To evaluate how 3M™ VHB Tapes can be used in your applications, contact your 3M Sales Specialist or call 1-866-279-1288, ext. 8005.

# 3M™ Protective Tapes

Many factors can affect the use and performance of a 3M™ Protective Tape Product in a particular application:

- Surface texture of substrate
- Surface preparation of substrate (including use of solvents)
- Method and conditions of tape application
- Time and environmental conditions
- Storage conditions

It is essential that the user evaluate the 3M™ Protective Tape Product to determine whether it is suitable for a particular purpose to meet the user's expectation.

## Ordering Information

3M™ Protective Tapes are custom ordered products. Please contact your local 3M Authorized distributor or your 3M Sales Specialist for ordering information.

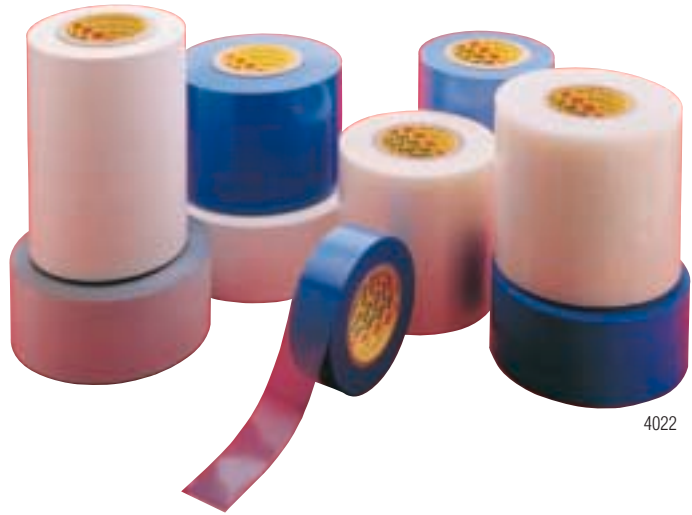

4022

Total Tape Thickness		2.0 Mil (0.05mm)															
		Product Number (Color Coded by Tape Family)															
<b>Backing</b>		Co-Ex.	Co-Ex.	Co-Ex.	Co-Ex.	Co-Ex.	Co-Ex.	Co-Ex.	Co-Ex.	Co-Ex.	Co-Ex.	Co-Ex.	PE	Co-Ex.	Co-Ex.	Co-Ex.	
<b>Tack Level</b>		VL	VL	VL	L	M	M	M	H	L	M	L	H	VL	L	M	
<b>Metals Uncoated</b>	<b>Aluminum</b>	Mill Finished															
		Galvanized															
		Anodized Specular															
		Anodized - Flat															
	<b>Stainless Steel</b>	#2B Annealed															
		#4 Mill Polished															
		#8 Mirrored															
	<b>Steel</b>	#10 Mirrored															
<b>Coated — Steel or Aluminum</b>	<b>Steel</b>	Laser Cuttable															
		<b>Embossed</b>	Flat														
			Gloss														
		Matte															
		Bronze															
		Dissimilar Metals															
Automotive Clear Coat																	

### How to use this Selection Guide

The 3M™ Protective Tape Products Selection Guide is a quick reference of standard 3M™ Protective Tape Products to help the user select appropriate tapes for consideration and evaluation in their applications. Products are color-coded by product family for easy reference. It is essential that the user evaluate the 3M™ Protective Tape Product to determine whether it is suitable for a particular purpose to meet the user's expectation.

### Protective Tape Product Families

**Polyethylene Tapes**

- Better transparency
- Good abrasion resistance
- Cost effective

**UV Tapes — Clear and Blue**

- Outdoor UV resistance for up to 5 months
- Available in transparent and blue

**UV Tapes — Co-Extruded Black/White**

- Enhanced outdoor UV resistance for up to 6 months

**Co-Extruded "A" Tapes**

The best choice in a 3M™ Protective Tape

- Excellent conformability
- Enhanced abrasion and puncture resistance
- Good heat resistance

### Tape Number Identification Guide

**Film Thickness**  
(nominal thickness in mils)  
Exception: 25A10 - 25 = 2.5 mils

**Film Color**  
B – Blue  
C – Clear  
W – White  
X – Black/White  
No Letter – Clear

# 3W26X

**Film Type**  
1 – LDPE  
4 – Polypropylene  
6 – Polyester  
A – Co-Extruded PE  
E – Co-Extruded PE  
(Carpet Tape Only)  
U – Translucent UV Stable Film  
W – Co-Extruded PE - Black/White

**Adhesive Type**  
**Adhesives:**  
04, 05, 10  
12, 14, 23, 42, 73  
25, 26, 29, 43, 56, 58  
67, 79, 82, 87, 88, 89  
93EZ, 95EZ

**Tack Level:**  
Very Low = VL  
Low = L  
Moderate = M  
High = H  
Very High = VH

2.5 Mil (0.06mm)					3.0 Mil (0.08mm)									Black/White 3.0 Mil (0.08mm)				4.0 Mil (0.10mm)				
25A26	25A29	25A87	25A88	25M26X	3104	3105	3110	3112	3125	3126	3179	3187	31U23C/UV	3W25X	3W26X	3W29X	3W55X	4112	4125	4126	4179	4187
Co-Ex.	Co-Ex.	Co-Ex.	PE	PE	PE	PE	PE	PE	PE	PE	PE	PE	PE	Co-Ex.	Co-Ex.	PE	PE	PE	PE	PE	PE	PE
M	M	H	H	M	VL	VL	VL	L	M	M	H	H	L	M	M	M	M	L	M	M	H	H

3M™ Protective Tapes Adhesives & Tapes

# Masking Products

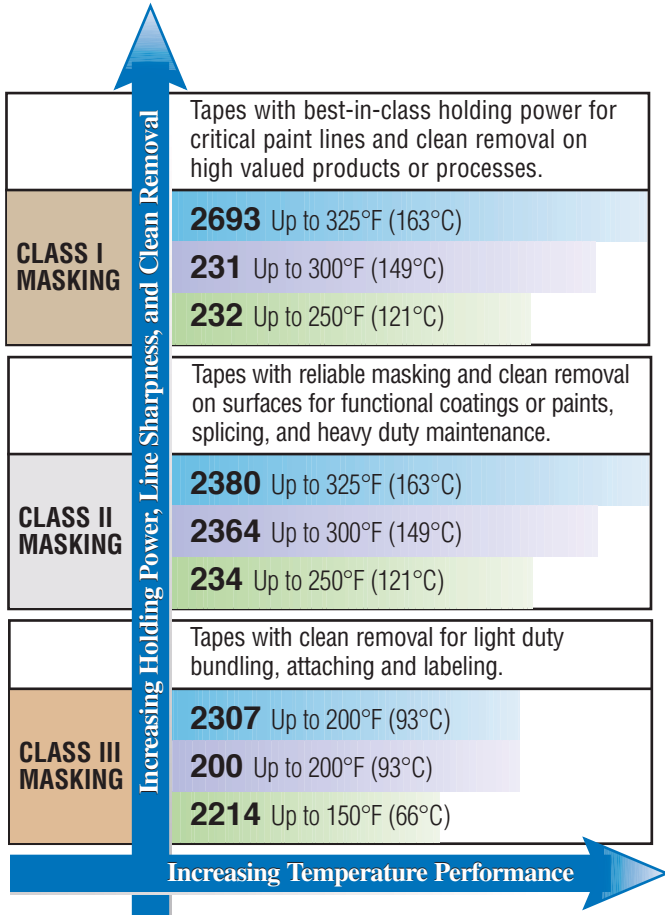

## 3M™ Paper Masking Tape 2214

Economical, quality, general purpose paper tape with rubber adhesive. Exceptional shear on corrugated boxes and exceptionally consistent adhesion. Use for bundling, sealing, holding and non-critical indoor jobs. 5.3 mil pressure sensitive tape resists slivering. Use up to 150°F. Natural.



148594

Size	UPC	Qty./Case	List Price
12mm x 55m	021200-45587-2	72	0.64
18mm x 55m	021200-26074-2	48	0.85
24mm x 55m	021200-26075-9	36	1.06
36mm x 55m	021200-26076-6	24	1.59
48mm x 55m	021200-26077-3	24	2.12
72mm x 55m	021200-26078-0	12	3.18

## Tartan™ Masking Tape 200

Natural colored, 5.5 mil (0.14 mm) crepe paper tape with rubber adhesive. Used for holding, bundling, sealing, non-critical masking, not to exceed 200°F, and a vast number of other jobs where a pressure sensitive tape is needed.



13372

Size	UPC	Qty./Case	List Price
12mm x 55m	021200-71183-1	72	0.64
18mm x 55m	021200-71182-4	48	0.98
24mm x 55m	021200-71180-0	36	1.27
36mm x 55m	021200-71179-4	24	1.90
48mm x 55m	021200-71177-0	24	2.55
72mm x 55m	021200-71176-3	12	3.82

## Tartan™ Masking Tape 2307

Heavy duty grade pressure sensitive masking tape. Increased backing strength and adhesive holding power for holding, bundling, sealing and non-critical paint masking. Use in temperatures up to 200°F.



86975

Size	UPC	Qty./Case	List Price
12mm x 55m	021200-71116-9	72	0.99
18mm x 55m	021200-71117-6	48	1.45
24mm x 55m	021200-71118-3	36	1.84
36mm x 55m	021200-71119-0	24	2.77
48mm x 55m	021200-71120-6	24	3.68
60mm x 55m	021200-55672-2	16	4.61
72mm x 55m	021200-71121-3	12	5.52

## Scotch® General Purpose Masking Tape 234

Ideal for general purpose industrial applications. Generally functions in bake cycles up to 250°F for up to one hour. Resists transfer and slivering, conforms well.



169188

Size	UPC	Qty./Case	List Price
24mm x 55m	021200-02982-0	36	4.27
36mm x 55m	021200-02983-7	24	6.45
48mm x 55m	021200-04244-7	24	8.61
72mm x 55m	021200-02985-1	12	12.82

104710

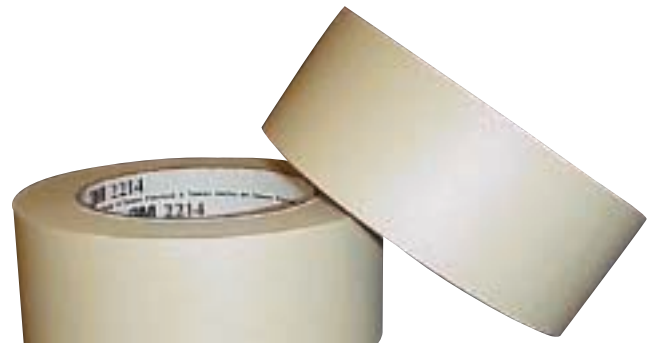

## Masking Products (cont.)

### Scotch® Performance Masking Tape 2364

A tan colored crepe paper masking tape for general masking applications where good holding power and temperature performance is required. Up to 300°F bake temperature. Designed for many industrial applications. Easy tearing and sliver resistance. Controlled unwind.



50859

Size	UPC	Qty./Case	List Price
24mm x 55m	021200-43352-8	36	2.12
36mm x 55m	021200-43353-5	24	3.18
48mm x 55m	021200-43354-2	24	4.24
72mm x 55m	021200-43355-9	12	6.36

### Scotch® Performance Masking Tape 2380

Designed for industrial paint masking applications at either room temperature or bake temperatures up to 325°F on most cold surfaces without adhesive transfer. Helps assure a good paint line whether air drying or oven baking. Includes a natural rubber/synthetic blend adhesive on a smooth mini-crepe paper treated backing.



50860

Size	UPC	Qty./Case	List Price
24mm x 55m	021200-44583-5	36	2.94
36mm x 55m	021200-44582-8	24	4.41
48mm x 55m	021200-44581-1	24	5.88
72mm x 55m	021200-44580-4	12	8.82

### Scotch® High Performance Masking Tapes 232

Excellent for paint masking. Sticks at a touch and stays put. Tough and smooth high performance crepe paper tape. Generally functions in bake cycles up to 250°F for up to one hour.



13373

Size	UPC	Qty./Case	List Price
24mm x 55m	021200-02854-0	36	5.15
36mm x 55m	021200-02855-7	24	7.73
48mm x 55m	021200-04240-9	24	10.30
72mm x 55m	021200-02858-8	12	15.45

### Scotch® Paint Masking Tape 231

Excellent for paint masking. Sticks at a touch and stays put. Tough and smooth high performance crepe paper tape. Generally functions in bake cycles up to 300°F for up to one hour.



86989

Size	UPC	Qty./Case	List Price
24mm x 55m	021200-03777-1	36	5.26
36mm x 55m	021200-04111-2	24	7.92
48mm x 55m	021200-04237-9	24	10.59
72mm x 55m	021200-04936-1	12	15.83

### Scotch® Premium High Performance Masking Tape 2693

Designed for automotive, truck and bus applications, where very aggressive room temperature and high temperature holding is required. Tan, 8.5 mils (0.21mm) mini-crepe paper tape with rubber adhesive. For use up to 325°F.



50862

Size	UPC	Qty./Case	List Price
24mm x 55m	021200-37629-0	36	3.33
36mm x 55m	021200-41121-2	24	5.00
48mm x 55m	021200-37630-6	24	6.66
72mm x 55m	021200-42979-8	12	9.99

### 3M™ Polyester/Silicone Tape 8952 (Blue)

This 3.5 mil tape is designed with a tough non-slivering polyester backing and clean removing high temperature silicone adhesives. Generally functions up to 425°F. Popular choice for powder coat print making.



50862

Size	UPC	Qty./Case	List Price
3/8" x 72 yds.	021200-48540-4	96	4.45
3/4" x 72 yds.	021200-48229-8	48	8.34



169191

## Masking Products (cont.)

### 3M™ Scotchblok™ Masking Paper Gold

Protects against dust contamination from its own paper fibers. Holds up well under wet sanding conditions. Excellent conformability. No solvent penetration. Back cycles up to 225°F (107°C) for thirty minutes. Gold.



Size	UPC	Qty./Case	List Price
18" x 750'	051131-06718-9	2	57.84

### 3M™ Masking Paper Bold Brick

A 2.7 mil treated paper, with temperature resistance of 400°F up to 30 minutes.



Size	UPC	Qty./Case	List Price
18" x 750'	021200-06618-4	2	59.79

### 3M™ Masking Paper White

For utility applications. Acceptable conformability. 28 lbs. treated paper.



Size	UPC	Qty./Case	List Price
18" x 750'	051131-06539-0	2	34.17



44954

## Box Sealing Tapes

### Scotch® Box Sealing Tape 375

Extremely versatile excellent performance box sealing tape. Seal heavy, high value, over packed, or under packed packages. Strong for demanding situations. Meets US postal regulations.



63222

Size	Color	UPC	Qty./Case	List Price
48mm x 50m	Clear	021200-72406-0	36	4.60
72mm x 50m	Clear	021200-72407-7	24	6.90
48mm x 50m	Tan	021200-72401-5	36	4.60
72mm x 50m	Tan	021200-72402-2	24	6.90

### Scotch® Box Sealing Tape 371

Seals single wall corrugated cartons or bundles a group reliably. Polypropylene backing for tear resistance. Pressure-sensitive rubber adhesive offers quick, moisture proof seal. This tape offers a good, tight, general purpose seal.



48050

Size	Color	UPC	Qty./Case	List Price
48mm x 50m	Clear	021200-13679-5	36	1.08
72mm x 50m	Clear	021200-19279-1	24	1.61
48mm x 50m	Tan	021200-14105-8	36	1.08
72mm x 50m	Tan	021200-18197-9	24	1.61

## Box Sealing Tape Dispensers

### Scotch® Box Sealing Tape Dispenser H122

Special braking system lets you control the amount of tape you use. Popular, light, plastic, contoured hand held dispenser. Small and portable, yet allows you to dispense tape up to 2" wide on a 3" core.



196837

Size	UPC	Qty./Case	List Price
2"	021200-06925-3	6	23.57

### Scotch® Box Sealing Tape Dispenser H180

Handheld, portable and easy to operate. Features an adjustable tape brake allowing control of tension and delivery. Dispenses tapes 2" wide and is constructed of plastic and metal.

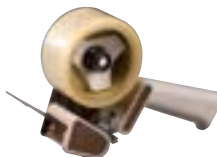

195186

Size	UPC	Qty./Case	List Price
2"	021200-19008-7	6	17.10

## Tartan® Box Sealing Hand Dispenser HB933

Seals cartons easily and secures a smooth, one-handed roll-on motion. The unique spring-loaded bar maintains constant tension during tape application. For tape rolls up to 3" wide on a 3" core.



196847

Size	UPC	Qty./Case	List Price
3"	021200-22922-0	6	19.93

## Duct Tapes

### 3M™ Duct Tape 3900

Polyethylene coated cloth with rubber adhesive. Economy grade duct tape. A good choice for general maintenance, wrapping, sealing and protecting.



150221

Size	Color	UPC	Qty./Case	List Price
48mm x 54.8m	Silver	051131-06976-8	24	5.11
48mm x 54.8m	Black	021200-49833-6	24	5.11
48mm x 54.8m	Yellow	021200-49828-2	24	5.11

### 3M™ Duct Tape 3903

Embossed vinyl film coated with rubber adhesive. Designed for general sealing, color coding, masking, wrapping and bundling, protecting and other light duty applications where easy unwind, easy tear and less adhesive transfer are important.



142980

Size	Color	UPC	Qty./Case	List Price
2" x 50 yds.	Gray	051131-06984-8	24	3.42
2" x 50 yds.	Black	051131-06995-4	24	3.42
2" x 50 yds.	Yellow	051131-06982-4	24	3.42



69451

Adhesives & Tapes  
Box Sealing  
Duct

# Safety Products

## 3M™ Particulate Respirators

**IMPORTANT:** Before use of these respiratory protection products, a written respiratory protection program must be implemented, meeting all the requirements of OSHA 29 CFR 1910.134 such as training, fit testing, medical evaluation and applicable OSHA substance specific standards.

### 3M™ Particulate Respirator 8000, N95



193020

**Applications:** Light duty, short duration applications, non-oil based particles

**Features:**

Two Straps	Pat. Filter Media	Nose Clip	Nose Foam	Ind. Pkg.	Collapse Resistant	3M™ Cool Flow™	Braided Strap	Carbon Media	M-Shape	Welding Web	Adj. Straps	Faceseal Ring	Cake Resistant
●	●	●											

Product	UPC	Qty./Case	List Price/Case
<b>3M™ Particulate Respirator 8000, N95</b>	051131-52967-5	240	88.15

### 3M™ Particulate Respirator 8210, N95



4893

**Applications:** Grinding, sanding, sweeping, bagging and other dusty operations

**Features:**

Two Straps	Pat. Filter Media	Nose Clip	Nose Foam	Ind. Pkg.	Collapse Resistant	3M™ Cool Flow™	Braided Strap	Carbon Media	M-Shape	Welding Web	Adj. Straps	Faceseal Ring	Cake Resistant
●	●	●	●										

Product	UPC	Qty./Case	List Price/Case
<b>3M™ Particulate Respirator 8210, N95</b>	051138-46457-3	160	133.68

### 3M™ Particulate Respirator 9210, N95



12411

**Applications:** Grinding, sanding, sweeping, bagging and other dusty operations

**Features:**

Two Straps	Pat. Filter Media	Nose Clip	Nose Foam	Ind. Pkg.	Collapse Resistant	3M™ Cool Flow™	Braided Strap	Carbon Media	M-Shape	Welding Web	Adj. Straps	Faceseal Ring	Cake Resistant
●	●	●	●	●	●								

Product	UPC	Qty./Case	List Price/Case
<b>3M™ Particulate Respirator 9210, N95</b>	051131-37021-5	240	225.43

### 3M™ Particulate Respirator 9211, N95



12412

**Applications:** Grinding, sanding, sweeping, bagging and other dusty operations

**Features:**

Two Straps	Pat. Filter Media	Nose Clip	Nose Foam	Ind. Pkg.	Collapse Resistant	3M™ Cool Flow™	Braided Strap	Carbon Media	M-Shape	Welding Web	Adj. Straps	Faceseal Ring	Cake Resistant
●	●	●	●	●	●	●							

Product	UPC	Qty./Case	List Price/Case
<b>3M™ Particulate Respirator 9211, N95</b>	051131-37022-2	120	198.72

### 3M™ Particulate Respirator 8511, N95



4899

**Applications:** Grinding, bagging, sanding, sweeping and other hot/dusty operations

**Features:**

Two Straps	Pat. Filter Media	Nose Clip	Nose Foam	Ind. Pkg.	Collapse Resistant	3M™ Cool Flow™	Braided Strap	Carbon Media	M-Shape	Welding Web	Adj. Straps	Faceseal Ring	Cake Resistant
●	●	●				●	●		●				

Product	UPC	Qty./Case	List Price/Case
<b>3M™ Particulate Respirator 8511, N95</b>	051138-54343-8	80	138.91



## 3M™ Particulate Respirators (cont.)

### 3M™ Particulate Respirator 8515, N95



50662

**Applications:** Welding, torch cutting, brazing, soldering, metal pouring, grinding, sanding, sweeping, bagging and other hot/dusty operations

**Features:**

Two Straps	Pat. Filter Media	Nose Clip	Nose Foam	Ind. Pkg.	Collapse Resistant	3M™ Cool Flow™	Braided Strap	Carbon Media	M-Shape	Welding Web	Adj. Straps	Faceseal Ring	Cake Resistant
●	●	●				●	●		●	●			

Product	UPC	Qty./Case	List Price/Case
3M™ Particulate Welding Respirator 8515, N95	051131-07189-1	80	187.99

### 3M™ Particulate Respirator 8271, P95



4900

**Applications:** Grinding, sanding, sweeping, bagging, machining and other dusty/oily operations

**Features:**

Two Straps	Pat. Filter Media	Nose Clip	Nose Foam	Ind. Pkg.	Collapse Resistant	3M™ Cool Flow™	Braided Strap	Carbon Media	M-Shape	Welding Web	Adj. Straps	Faceseal Ring	Cake Resistant
●	●	●				●	●		●			●	

Product	UPC	Qty./Case	List Price/Case
3M™ Particulate Respirator 8271, P95	051138-54285-1	80	217.01

### 3M™ Particulate Respirator Welding Respirator with Faceseal Ring 8212, N95



4894

**Applications:** Welding, brazing, soldering, torch cutting, metal pouring, grinding, sanding, sweeping, bagging and other dusty/hot operations

**Features:**

Two Straps	Pat. Filter Media	Nose Clip	Nose Foam	Ind. Pkg.	Collapse Resistant	3M™ Cool Flow™	Braided Strap	Carbon Media	M-Shape	Welding Web	Adj. Straps	Faceseal Ring	Cake Resistant
●	●	●				●	●			●	●	●	●

Product	UPC	Qty./Case	List Price/Case
3M™ Particulate Welding Respirator with Faceseal Ring 8212, N95	051138-54141-0	80	403.15

### 3M™ Particulate Respirator with Faceseal Ring and Nuisance Level Organic Vapor Relief, 8214, N95



4895

**Applications:** Welding, torch cutting, brazing, soldering, metal pouring, stainless and galvanized

**Features:**

Two Straps	Pat. Filter Media	Nose Clip	Nose Foam	Ind. Pkg.	Collapse Resistant	3M™ Cool Flow™	Braided Strap	Carbon Media	M-Shape	Welding Web	Adj. Straps	Faceseal Ring	Cake Resistant
●	●	●				●	●	●		●	●	●	●

Product	UPC	Qty./Case	List Price/Case
3M™ Particulate Respirator with Faceseal Ring and Nuisance Level Organic Vapor Relief, 8214, N95	051138-66192-7	80	482.18



## WARNING

These respirators help reduce exposure to certain airborne contaminants. **Misuse may result in sickness or death.** Before use, the wearer must read and understand **User Instructions** provided as a part of product packaging. Time use limitations may apply. For proper use, see package instructions, supervisor or call 3M OH&ESD Technical Service in U.S.A., 1-800-243-4630. In Canada, call 1-800-267-4414.

# 3M™ Full and Half Facepiece Respirators

Respirator and filters provide an easy-to-use, comfortable, wide range of respiratory protection.

## STEPS TO CHOOSING THE RIGHT PRODUCT FOR YOUR NEEDS

### 1 CHOOSE FACEPIECE

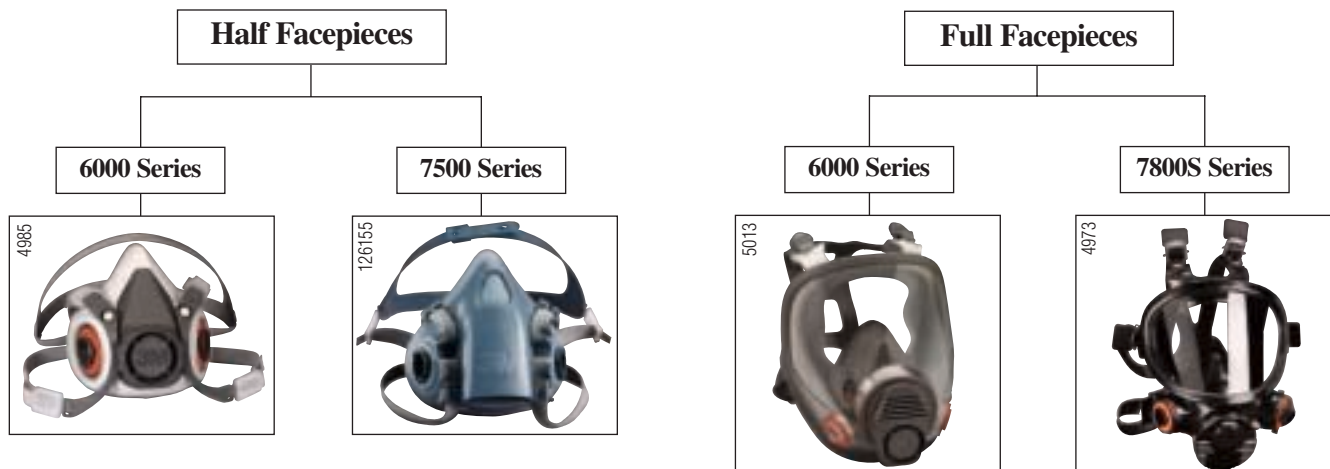

### 2 CHOOSE FILTER/CARTRIDGE COMBINATION



### 3 CHOOSE FILTER

- 2091
- 2097

- 6001
- 6003
- 6006

- 60921
- 60923
- 60926

### 3M™ Half Facepiece Respirators 6000 Series



4985

**Applications:** Painting, welding, metalworking and auto manufacturing

**Features:**

- Low maintenance

- Allows the use of replaceable cartridges and filters
- Designed for comfort, convenience and economy
- Can be used with 3M™ Filters 2000 Series, 3M™ Filter 7093, P100, 3M™ Cartridges 6000 Series, or 3M™ Dual Airline systems against a variety of gases, vapors and particulate hazards according to NIOSH approvals

Product	Model	Size	UPC	Qty./Case	List Price/Case
3M™ Half Facepiece Respirators 6000 Series	6100	S	051131-07024-5	24	242.65
	6200	M	051131-07025-2	24	242.65
	6300	L	051131-07026-9	24	242.65

## 3M™ Full and Half Facepiece Respirators (cont.)

### 3M™ Half Facepiece Respirators 7500 Series



126155

**Applications:** Painting, welding, metalworking and auto manufacturing

- Features:**
- Made of silicone for increased comfort and durability
  - Can accommodate many different cartridges and filters
  - 3M™ Cool Flow™ Exhalation Valve enhances wearer comfort and face fit
  - Can be used with any of the 3M™ Filters and Cartridges, Series 2000, 5000, 6000 and 7093

Product	Model	Size	UPC	Qty./Case	List Price/Case
<b>3M™ Half Facepiece 7500 Series, Ultimate Reusable</b>	7501	S	051131-37081-9	10	206.44
	7502	M	051131-37082-6	10	206.44
	7503	L	051131-37083-3	10	206.44

### 3M™ Full Facepiece Respirators 6000 Series



5013

**Applications:** Painting, welding, metalworking and auto manufacturing

- Features:**
- Low maintenance
  - Allows the use of replaceable cartridges and filters
  - Designed for comfort, convenience and economy
  - Can be used with 3M™ Filters 2000 Series, 3M™ Filter 7090 P100, 3M™ Cartridges 6000 Series or 3M™ Dual Airline systems against a variety of gases, vapors and particulate hazards according to NIOSH approvals

Product	Model	Size	UPC	Qty./Case	List Price/Case
<b>3M™ Full Facepiece Respirators 6000 Series</b>	6700	S	051131-54145-8	4	418.26
	6800	M	051131-54146-5	4	418.26
	6900	L	051131-54159-5	4	418.26

### 3M™ Full Facepiece 7800S Series, Silicone, Ultimate Reusable



126155

**Applications:** Painting, welding, metalworking and auto manufacturing

- Features:**
- Made of silicone for increased comfort and durability
  - Can accommodate many different cartridges and filters
  - Use with 3M™ Filters 2000 Series, 3M™ Cartridges 6000 Series, 3M™ Cartridges and Filters 7000 Series or a variety of powered and supplied air systems against a variety of gases, vapors and particulates according to NIOSH approvals
  - Not for use with 3M™ SCBA systems
  - Use 3M™ Full Facepieces 7800S-BA or 7800S-AM with appropriate SCBA systems

Product	Model	Size	UPC	Qty./Case	List Price/Case
<b>3M™ Full Facepiece 7800S Series, Silicone, Ultimate Reusable</b>	7800S-S	S	051138-54257-3	1	217.78
	7800S-M	M	051138-54258-0	1	217.78
	7800S-L	L	051138-54259-7	1	217.78



## ⚠ WARNING

These respirators help reduce exposure to certain airborne contaminants. **Misuse may result in sickness or death.** Before use, the wearer must read and understand **User Instructions** provided as a part of product packaging. Time use limitations may apply. For proper use, see package instructions, supervisor or call 3M OH&ESD Technical Service in U.S.A., 1-800-243-4630. In Canada, call 1-800-267-4414.

# Filters and Retainers

## 3M™ Particulate Filter 2091, P100

NIOSH approved for environments containing certain oil and non-oil based particles. Use with 3M™ Respirators 5000 Series or Cartridges 6000 Series with 3M™ Adapter 502, 3M™ Facepieces 6000 Series or 3M™ Facepieces 7000 Series with bayonet filter holders.



4911

UPC	Qty./Case	List Price/Case
051131-07000-9	50 Pairs	262.03

## 3M™ Particulate Filter with Nuisance Level\* Organic Vapor Relief 2097, P100

NIOSH approved for environments containing certain oil and non-oil based particles. Use with 3M™ Facepieces 6000 Series or 3M™ Facepieces 7000 Series with bayonet filter holders. 3M recommended for relief from nuisance levels\* of organic vapors.



89287

UPC	Qty./Case	List Price/Case
051131-07184-6	50 Pairs	356.00

\* Nuisance levels are below OSHA PEL, or applicable government occupational exposure limits, whichever is lower.

## 3M™ Organic Vapor Cartridge 6001

Use with 3M™ Half and Full Facepieces 6000 Series and 3M™ Half 7500 Series and Full Facepiece 7800 Series with bayonet style cartridge holders. NIOSH approved against certain organic vapors. Use in a variety of workplace applications including petrochemical, chemical manufacturing, construction, transportation and electronics.



7209

UPC	Qty./Case	List Price/Case
051138-21674-5	30 Pairs	247.92

## 3M™ Organic Vapor/Acid Gas Cartridge 6003

Use with 3M™ Half and Full Facepieces 6000 Series and 3M™ Half 7500 Series and Full Facepiece 7800 Series with bayonet style cartridge holders. NIOSH approved against certain organic vapors and chlorine, hydrogen chloride, sulfur dioxide, or hydrogen sulfide (escape only) or hydrogen fluoride. Use in a variety of applications, including pharmaceutical, petrochemical, utilities, aluminum reduction, chemical manufacturing, laboratories, pulp and paper.



7211

UPC	Qty./Case	List Price/Case
051131-07047-4	30 Pairs	268.51

## 3M™ Multi Gas/Vapor Cartridge 6006

Use with 3M™ Half and Full Facepieces 6000 Series and 3M™ Half 7500 Series and Full Facepiece 7800 Series with bayonet style cartridge holders. NIOSH approved against certain organic vapors, chlorine, hydrogen chloride, sulfur dioxide, chlorine dioxide, hydrogen sulfide (escape only), ammonia, methylamine, formaldehyde or hydrogen fluoride. Use in a variety of applications, including petrochemical and chemical processing, utilities, pharmaceuticals, mining and primary metals.



7216

UPC	Qty./Case	List Price/Case
051138-54186-1	30 Pairs	272.30

## Filters and Retainers (cont.)

### 3M™ Cartridge/Filter Organic Vapor/P100 60921

Use with 3M™ Half and Full Facepieces 6000 Series, 3M™ Half 7500 Series and Full Facepiece 7800 Series with bayonet style cartridge holders. NIOSH approved against certain organic vapors and particulates. Use in a variety of applications including petrochemical, construction, transportation and chemical manufacturing.



44880

UPC	Qty./Case	List Price/Case
051131-46465-8	30 Pairs	503.17

### 3M™ Cartridge/Filter Multi Gas/Vapor/P100 60926

Use with 3M™ Half and Full Facepieces 6000 Series, 3M™ Half 7500 Series and Full Facepiece 7800 Series with bayonet style cartridge holders. NIOSH approved against certain organic vapors, chlorine, hydrogen chloride, sulfur dioxide, chlorine dioxide, hydrogen sulfide (escape only), ammonia, methylamine, formaldehyde or hydrogen fluoride and particulates. Use in a variety of applications including petrochemical and chemical processing, utilities, pharmaceuticals, mining and primary metals.



44875

UPC	Qty./Case	List Price/Case
051138-54187-8	30 Pairs	553.20

### 3M™ Cartridge/Filter Organic Vapor/Acid Gas/P100 60923

Use with 3M™ Half and Full Facepieces 6000 Series, 3M™ Half 7500 Series and Full Facepiece 7800 Series with bayonet style cartridge holders. NIOSH approved against certain organic vapors, acid gases and particulates. Use in a variety of applications including petrochemical, laboratories, pharmaceutical and chemical manufacturing.



44878

UPC	Qty./Case	List Price/Case
051138-46467-2	30 Pairs	503.17

### 3M™ Half Facepiece Respirators 5000 Series



34652

**Applications:** Spray painting, pesticides, agriculture, construction and transportation

- Features:**
- Dual cartridge respirator assembly
  - Permanently attached cartridges for ease of use and little or no maintenance
  - NIOSH approved against certain organic vapors and particulates

Product	Model	Size	UPC	Qty./Case	List Price/Case
3M™ Half Facepiece Respirators 5000 Series	51P71	S	051138-66068-5	12	235.91
	52P71	M	051138-66069-2	12	235.91
	52P73	L	051138-66070-8	12	235.91

**NOTE:** Many other cartridges and filters are available. Please visit [www.3M.com/occsafety](http://www.3M.com/occsafety) for details and information on other models.

# 3M™ Speedglas™ Welding Products

These products provide a high level of comfort and protection for welders in a variety of applications. Unique features give the user the best choice of affordability and functionality. With larger filter size and SideWindows for better overall viewing of the welding area, 3M™ Speedglas™ Auto-Darkening Systems were designed with the automotive aftermarket in mind. List prices are per individual unit.



279352

## 3M™ Speedglas™ Helmets and Filters



	 Utility Filter and Helmet 283466	 9000F Filter 282642	 9000XF 283461	 9002V Filter 286314	 9002X Filter 286310
	 Utility Filter 298563	 9000F Filter 282670	 9000XF Filter 286312	 9002V Filter 286309	 9002X Filter 286306
	Utility	9000F	9000XF	9002V	9002X
Standard Helmet	\$172.45 04-0014-10U*	\$244.90 04-0012-10**	\$280.61 04-0012-10X**	\$305.10 04-0012-31	\$397.96 04-0012-21
SideWindows	N/A	\$265.31 04-0012-10SW**	\$301.02 04-0012-10XSW**	\$325.51 04-0012-31SW	\$418.37 04-0012-21SW
ProTop	N/A	\$316.33 04-0015-10**	\$352.04 04-0015-10X**	\$376.53 04-0015-31	\$469.39 04-0015-21
ProTop with SideWindows	N/A	\$336.73 04-0015-10SW**	\$372.45 04-0015-10XSW**	\$396.94 04-0015-31SW	\$489.80 04-0015-21SW
FlexView	N/A	\$327.55 04-0016-10**	\$363.27 04-0016-10X**	\$387.76 04-0016-31	\$480.61 04-0016-21
FlexView with SideWindows	N/A	\$347.96 04-0016-10SW**	\$383.67 04-0016-10XSW**	\$408.16 04-0016-31SW	\$501.02 04-0016-21SW
FlexView with ProTop	N/A	\$383.69 04-1516-10**	\$419.39 04-1516-10X**	\$443.88 04-1516-31	\$536.73 04-1516-21
FlexView with ProTop and SideWindows	N/A	\$404.08 04-1516-10SW**	\$439.80 04-1516-10XSW**	\$464.29 04-1516-31SW	\$557.14 04-1516-21SW

\* Last two numbers indicate Shade, either 10 or 11.

\*\* Last two numbers indicate Shade, either 10, 11 or 12. E.G. A 9000F lens in a standard helmet, shade 10 would be product number 04-0012-10. The same helmet in shade 11 would be product number 04-0012-11.

Safety Products  
 3M™ Speedglas™  
 Welding Products

# Hearing Protection

**WARNING: HEARING PROTECTION PRODUCTS**  
 These hearing protection products help prevent hearing loss against certain noises. To provide proper protection, the hearing protector should be (1) suitable for the job, (2) fitted properly in/on the ear, (3) worn during all times of exposure to noise, and (4) replaced when damaged or otherwise necessary. Failure to fit and use hearing protectors according to these instructions will reduce their effectiveness. Failure to wear hearing protectors 100% of the time that you are exposed to hazardous noise may dramatically increase your risk of developing hearing loss. Keep ear plugs away from infants and small children. They may get caught in a child's windpipe.

## 3M™ Foam Ear Plug 1100

Smooth dirt resistant surface and tapered shape fit the ear canal and provide added comfort and hygiene. Hypo-allergenic material. Each box contains 200 pairs, and each package is easy to dispense. Noise Reduction Rating: 29dB.



UPC	Qty./Case	List Price/Case
051138-29008-0	1000 Pairs	96.69

## 3M™ Corded Foam Ear Plug 1110

Soft, corded foam ear plugs that conform to the unique shape of each ear for excellent hearing protection. Smooth dirt resistant surface and tapered shape fit the ear canal and provide added comfort and hygiene. Hypo-allergenic material. Each box contains 100 pairs, and each package is easy to dispense. Noise Reduction Rating: 29dB.



UPC	Qty./Case	List Price/Case
051138-29009-7	500 Pairs	110.20

## 3M™ Soft Foam Ear Plug 1120

Soft foam helps reduce pressure in the ear canal for improved comfort. Patented articulated shape for improved fit. Rolls down small for easier insertion and fit for small ear canals. Hypo-allergenic material. Bright orange color for visibility. Can be combined with ear muffs for additional protection. Noise Reduction Rating: 28dB.



UPC	Qty./Case	List Price/Case
051131-37062-8	1000 Pairs	96.69

## 3M™ Soft Foam Ear Plug 1130 Corded

Soft foam helps reduce pressure in the ear canal for improved comfort. Patented articulated shape for improved fit. Rolls down small for easier insertion and fit for small ear canals. Hypo-allergenic material. Bright orange color for visibility. Can be combined with ear muffs for additional protection. Soft braided polyester cord for convenience. Noise Reduction Rating: 28dB.

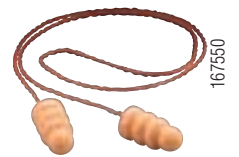

UPC	Qty./Case	List Price/Case
051131-37063-5	500 Pairs	110.20

## 3M™ Reusable Ear Plugs Corded with Carrying Case

Multi-flanged plugs stay securely in ear canal. Soft, cloth cord keeps plugs clean and protected. Model 1271 includes storage case to keep plugs clean and protected. Washable and reusable. Bright orange color for visibility. Noise Reduction Rating: 24dB.



UPC	Qty./Case	List Price/Case
051131-52850-0	250 Pairs	345.88

## 3M™ Banded Hearing Protector 1310

Flexible band makes fitting easy and maintains low pressure over a wide range of head sizes. Replacement tips are designed for comfort and hygiene. Noise Reduction Rating: 20dB.



UPC	Qty./Case	List Price/Case
051138-66003-6	50	198.40

## 3M™ Replacement Pads 1311

Replacement pads attach to the unique flexible band of the 3M™ Banded Hearing Protector 1310. Conforms to the unique shape of the ear canal opening for greater comfort and secure fit. Cost effective and easy to replace. Smooth, dirt resistant surface for hygiene.



UPC	Qty./Case	List Price/Case
051138-66004-3	100 Pairs	88.17

Safety Products  
Hearing Protection

## Hearing Protection (cont.)

### 3M™ Ear Muffs 1440

Lightweight, padded headband with tension adjustment. Contoured ear cushion in multi-position ear cup gives excellent sound insulation. Replaceable cushions and molded noise suppression inserts. Noise Reduction Rating: 24dB.



247039

UPC	Qty./Case	List Price/Case
051138-29334-0	20 Pairs	450.56

### 3M™ Ear Muffs 1435

General purpose ear muffs. Wide, forked headband and multi-position large ear cup help create a secure fit. Lightweight design. Replaceable, soft sealing cushions. Noise Reduction Rating: 23dB.



7166

UPC	Qty./Case	List Price/Case
051138-29333-3	20 Pairs	260.65

## Sorbents

### 3M™ Maintenance Sorbent Folded M-FL5500DD

Easy-to-use solution for cleaning up spills, drips and fluid leaks. Versatile: can be used in pillow, pad, roll or boom configuration. Has a scrim on one side to increase strength and help eliminate linting. Dispenses from a carrying/dispenser box in the form of a continuous roll. Less waste: perforated every 16 inches so you can select the length required. Applications range from maintenance to spill response.



3835

Model	Size	UPC	Qty./Case	List Price/Case
M-FL5500DD	5" x 50'	051138-29071-9	3 Boxes	104.16

### 3M™ Maintenance Sorbent Rug M-RG36300E

Use in areas where foot and vehicle traffic is a concern. Will sorb liquids while enduring the punishment of being tread upon. Durable and versatile. Use in industrial maintenance applications.



3841

Model	Size	UPC	Qty./Case	List Price/Case
M-RG36300E	36" x 300'	051138-29002-3	1 Rug	297.46



89288

### 3M™ Maintenance Sorbent Mini-Boom

Tube-like shape is ideal for placing around machinery to contain spills and prevent leaks from spreading into adjacent work areas. 3 inch diameter scrim on the outside of the boom identifies the use while containing particulate sorbent material designed for the application.



3840

Model	Size	UPC	Qty./Case	List Price/Case
M-MB304	3' x 4'	051138-21526-7	12	62.93
M-MB308	3' x 8'	051138-21527-4	6	62.93

### 3M™ Petroleum Sorbent Pad HP-156

Low-profile design can be easily placed in tight areas. Ideal for cleaning up small spills and wiping down contaminated areas. Has a scrim on one side to increase strength and help eliminate linting. Conveniently sized, allows the user to quickly spread sorbent over and in the path of a spill. Can also be used on a work surface in anticipation of a spill or as a wipe.



6756

Model	Size	UPC	Qty./Case	List Price/Case
HP-156	17" x 19"	051138-28911-4	100	53.78

### 3M™ Petroleum Sorbent Pad T-151

This highly sorbent pad features a low-profile design for easy placement in tight areas. Ideal for cleaning up small spills and wiping down contaminated areas.



6714

Model	Size	UPC	Qty./Case	List Price
T-151	21" x 100'	021200-16049-3	200	80.39



# Eye Protection

## WARNING

3M Protective Eyewear Products help provide limited eye and face protection against flying particles. Misuse or failure to follow warnings and instructions may result in serious personal injury, including blindness or death. For proper use see supervisor, read instructions and warnings on the package, or call 3M Occupational Health and Environmental Safety Division (OH&ESD) Technical Service in the U.S.A. at 1-800-243-4630.

## 3M™ Protective Eyewear 1700 Series

Meets the requirements of the American National Standard Practice for Occupational and Educational Eye and Face Protection, ANSI Z87.1-1989. Stylish wrap-around design helps provide side protection. Hard-coated, polycarbonate lenses offer 99% UV protection. Lightweight. Low profile frameless design.



59082

Model	UPC	Color (Frame/Lens)	Qty./Case	List Price/Case
1700	051138-37103-8	Black/Clear	24	92.68
1701	051138-76800-8	Smoke/Smoke	24	92.68
1702	051138-76801-5	Clear/Clear	24	92.68



293527

## 3M™ Protective Eyewear 1750 Series

Stylish safety eyewear with a contemporary appearance. Lightweight and shaped to fit facial contours. Comfortable fit afforded by gel-like nose piece and soft temples. Polycarbonate lens offers 99% UV protection, and has anti-scratch coating. Meets ANSI Z87.1-2003.



228200

Model	UPC	Color (Frame/Lens)	Qty./Case	List Price/Case
1750	051131-37113-7	Gray/Clear	24	153.36
1751	051131-37114-4	Gray/Smoke	24	153.36
1752	051131-37115-1	Blue/Mirrored	24	185.04

## 3M™ Protective Eyewear 1760 Series

Stylish safety eyewear with a contemporary appearance. Lightweight and shaped to fit facial contours. Comfortable fit afforded by a soft rubber nose piece with rubber tips. Polycarbonate lens offers 99% UV protection and has anti-scratch coating. Meets ANSI Z87.1-2003.



290312

Model	UPC	Color (Frame/Lens)	Qty./Case	List Price/Case
1760	051131-37116-8	Clear/Clear	24	145.92

# Welding Products

## Welding Products

### 3M™ Weld-Thru Coating — Silver

An aerosol coating designed to be applied to metal surfaces prior to welding which permits corrosion protection after the weld.

- Dries fast (10–15 minutes)
- Minimizes MIG weld spatter
- May be applied after the weld for additional corrosion protection



49829

Size	UPC	Qty./Case	List Price/Can
16 oz.	051131-05913-9	12	20.38

### 3M™ Welding and Spark Deflection Paper

- Flame retardant
- Repositionable adhesive on one side
- Formulated to protect vertical surfaces, glass and paint from welding spatter and grinding sparks
- Easy to use roll form



43640

Size	UPC	Qty./Case	List Price/Roll
24" x 150'	051131-05916-0	2	81.45

### 3M™ Welding and Spark Deflection Dispenser

- Dispenses single rolls of 24" 3M™ Welding and Spark Deflection Paper
- Can be wall or table mounted
- Very easy to assemble



155352

UPC	Qty./Case	List Price/Each
051131-05912-2	1	60.47

### 3M™ High Performance Welding Drape

- Extreme resistance to heat, sparks, welding spatter and flames
- Ideal for protection from automotive welding spatter and grinding sparks
- Very lightweight, conformable and easy to handle
- Excellent wear and tear resistance
- Easy to clean by brushing or shaking



130884

Size	UPC	Qty./Case	List Price/Each
57" x 80'	051131-05919-1	1	232.55

32940



# ■ Mattings

## 3M™ Matting

### 3M™ Safety-Walk™ Cushion Matting 3270 & 3270E

- Economical matting ideal for fatigue resistance in dry environments
- Textured, solid surface improves traction and allows debris and liquid to stay on top of the mat for easy cleanup
- Lightweight for easy moving and repositioning
- 3270E has integral edging on the long edge of the mat and nosing on the ends
- 3270 (no edging)



31783

Size	Color	UPC	Qty./Case	List Price/Each
<b>3270 (With No Edging)</b>				
<b>3' x 5'</b> 3270	Black	048011-34819-3	1	51.84
<b>4' x 6'</b> 3270	Black	048011-34820-9	1	82.96
<b>3' x 10'</b> 3270	Black	048011-34821-6	1	103.69
<b>4' x 10'</b> 3270	Black	048011-34822-3	1	138.25
<b>3' x 20'</b> 3270	Black	048011-34823-0	1	207.37
<b>4' x 20'</b> 3270	Black	048011-34824-7	1	276.50
<b>3270E (With Black Edging)</b>				
<b>3' x 5'</b> 3270E	Black	048011-34826-1	1	58.03
<b>4' x 6'</b> 3270E	Black	048011-34827-8	1	92.83
<b>3' x 10'</b> 3270E	Black	048011-34828-5	1	116.03
<b>4' x 10'</b> 3270E	Black	048011-34829-2	1	154.70
<b>3' x 20'</b> 3270E	Black	048011-34830-8	1	232.05
<b>4' x 20'</b> 3270E	Black	048011-34831-5	1	309.41



47824

### 3M™ Safety-Walk™ Cushion Matting 3600

- More loft from less bulk
- Necessary cushion to help reduce discomfort
- A durable mat that's easily moved
- Excellent traction to help prevent slips and mat movement
- Open construction allows water and small debris to pass through

Size	Color	UPC	Qty./Case	List Price/Case
<b>No Edging</b>				
<b>2' x 35'</b>	Black	048011-23464-4	4	213.62
<b>5' x 35'</b>	Black	048011-23465-1	1	133.48
<b>Beveled Edging</b>				
<b>2' x 35'</b>	Black	048011-23479-8	4	417.05
<b>2' x 38'</b>	Black	048011-23480-4	4	552.66
<b>5' x 35'</b>	Black	048011-23483-5	1	184.34
<b>5' x 38'</b>	Black	048011-23484-2	1	269.11

# Cleaners/Maintenance

## Cleaners

### 3M™ 5-Way Penetrant

Inhibits rust and corrosion by spreading a thin, even film that actually penetrates the pores of the surface. It displaces moisture and “dries out” electrical parts and equipment to help prevent shorting and increase conductivity. Spray it on to free rusted, frozen bolts, nuts, and screws. Lubricate delicate machines and precision instruments. Penetrates and demoisturizes. Ideal as a tapping lubricant for stainless steel and aluminum. Contains no methylene chloride, 1, 1, 1-trichloroethane or chlorofluorocarbons.



243698

Size	UPC	Qty./Case	List Price/Each
24 fl. oz.	021200-21305-2	12	8.92

### 3M™ Citrus Base Cleaner

A multi-purpose cleaner which will dissolve and flush away dirt, grease, tar, most noncuring type adhesive films and similar substances. It is a citrus oil-based cleaner that emulsifies when flushed with water. It contains no petroleum distillates. Can be used to clean and degrease metal parts, motors, tools, printing presses and concrete. Contains no methylene chloride, 1, 1, 1-trichlorofluorocarbons.



243700

Size	UPC	Qty./Case	List Price/Each
24 fl. oz.	021200-76394-6	12	13.76

### 3M™ Stainless Steel Cleaner and Polish

Aerosol product that cleans and polishes stainless steel, chrome aluminum and laminated plastic surfaces to a high gloss in one step. Contains no ozone depleting chemicals.



221761

Size	UPC	Qty./Case	List Price/Case
21 fl. oz.	048011-14002-0	12	102.24

## Concrete Repair

### 3M™ Concrete Repair Gray, Self-Leveling 8.4 fl. oz. (250 ml) Cartridge

Self-leveling urethane flows smoothly into cleaned cracks and gaps. Hardens to any depth without cracking or shrinking. Flexible urethane expands and contracts for durability that outlasts repairs made with concrete. Solvent-free. Do-it-yourself with a common caulking gun.



245069

Kit Contains	Color	UPC	Qty./Case	List Price/Each
8.4 oz. cartridge 2 mix nozzles	Gray	021200-96596-8	6	23.67

### 3M™ Self-Leveling Urethane Repair Kit, Fast Set

Kit contains:

- 4 each – 3M™ Concrete Repair DP600, Self-Leveling, Gray 12 oz. cartridges
- 1 each – 3M™ Blunt End Mix Tip 4901
- 1 each – 3M™ Polyethylene Spreader
- 1 each – 3M™ Manual Applicator 6997-1

Description	UPC	Qty./Case	List Price/Case
3M™ Self-Leveling Repair Kit	021200-96327-8	1	156.00



# UPC Index

The following UPC numbers are in numeric order with corresponding page numbers.

021200-02854-0.....53	021200-44580-4.....53	048011-00580-5.....24	048011-05820-7.....24	048011-14285-2.....24
021200-02855-7.....53	021200-44581-1.....53	048011-00583-6.....24	048011-05974-7.....30	048011-14379-8.....25
021200-02858-8.....53	021200-44582-8.....53	048011-00590-4.....24	048011-05975-4.....30	048011-14543-3.....24
021200-02982-0.....52	021200-44583-5.....53	048011-00643-7.....15	048011-07458-0.....15	048011-14550-1.....24
021200-02983-7.....52	021200-45587-2.....52	048011-00645-1.....15	048011-07459-7.....15	048011-14587-7.....30
021200-02985-1.....52	021200-48229-8.....53	048011-00665-9.....14	048011-07494-8.....15	048011-14588-4.....30
021200-03777-1.....53	021200-48540-4.....53	048011-00666-6.....14	048011-08707-8.....40	048011-14590-7.....31
021200-04111-2.....53	021200-49110-8.....47	048011-00672-7.....14	048011-08713-9.....40	048011-14593-8.....31
021200-04237-9.....53	021200-49828-2.....55	048011-00750-2.....15	048011-08764-1.....12	048011-14594-5.....31
021200-04240-9.....53	021200-49833-6.....55	048011-00751-9.....15	048011-08765-8.....12	048011-14629-4.....26
021200-04244-7.....52	021200-50004-6.....48	048011-00941-4.....14	048011-08766-5.....12	048011-14750-5.....25
021200-04936-1.....53	021200-50045-9.....45	048011-00948-3.....14	048011-08856-3.....24	048011-14751-2.....25
021200-06618-4.....54	021200-55672-2.....52	048011-00957-5.....14	048011-08857-0.....24	048011-14752-9.....25
021200-06925-3.....55	021200-56002-6.....49	048011-03262-7.....26	048011-08858-7.....24	048011-14753-6.....25
021200-13679-5.....55	021200-56146-7.....49	048011-03270-2.....26	048011-08880-8.....24	048011-14779-6.....31
021200-14105-8.....55	021200-56229-7.....49	048011-03992-3.....14	048011-08915-7.....24	048011-14780-2.....31
021200-16049-3.....64	021200-56375-1.....49	048011-03998-5.....24	048011-09448-9.....15	048011-14781-9.....30
021200-16954-0.....49	021200-59967-5.....49	048011-03999-2.....24	048011-09450-2.....15	048011-14783-3.....30
021200-16955-7.....49	021200-64886-1.....49	048011-04018-9.....25	048011-09493-4.....38	048011-15012-3.....25
021200-16961-8.....49	021200-64887-8.....49	048011-04020-2.....39	048011-09548-6.....26	048011-15118-2.....25
021200-18090-3.....49	021200-64888-5.....49	048011-04021-9.....14	048011-09549-3.....26	048011-15408-4.....25
021200-18091-0.....49	021200-64963-9.....46	048011-04028-8.....38	048011-09551-6.....26	048011-15408-4.....31
021200-18092-7.....49	021200-71116-9.....52	048011-04029-5.....38	048011-09552-3.....26	048011-15527-2.....25
021200-18197-9.....55	021200-71117-6.....52	048011-04050-9.....38	048011-09650-6.....24	048011-15859-4.....25
021200-19008-7.....55	021200-71118-3.....52	048011-04051-6.....38	048011-13170-2.....26	048011-15899-0.....24
021200-19279-1.....55	021200-71119-0.....52	048011-04085-1.....39	048011-13171-9.....26	048011-16054-2.....25
021200-19718-5.....46	021200-71120-6.....52	048011-04120-9.....15	048011-13172-6.....26	048011-16544-8.....25
021200-19721-5.....46	021200-71121-3.....52	048011-04124-7.....15	048011-13176-4.....26	048011-16545-5.....25
021200-19808-3.....46	021200-71176-3.....52	048011-04132-2.....15	048011-13177-1.....26	048011-16622-3.....30
021200-19868-7.....46	021200-71177-0.....52	048011-04188-9.....14	048011-13178-8.....26	048011-16859-3.....26
021200-19887-8.....46	021200-71179-4.....52	048011-04189-6.....24	048011-13182-5.....26	048011-16860-9.....26
021200-19890-8.....46	021200-71180-0.....52	048011-04190-2.....24	048011-13183-2.....26	048011-17183-8.....25
021200-19892-2.....46	021200-71182-4.....52	048011-04270-1.....40	048011-13184-9.....26	048011-17184-5.....25
021200-19894-6.....46	021200-71183-1.....52	048011-04276-3.....15	048011-13185-6.....26	048011-17185-2.....25
021200-19897-7.....46	021200-72401-5.....55	048011-04277-0.....15	048011-13186-3.....26	048011-17186-9.....25
021200-20272-8.....46	021200-72402-2.....55	048011-04283-1.....24	048011-13237-2.....12	048011-17190-6.....25
021200-20274-2.....46	021200-72406-0.....55	048011-04289-3.....24	048011-13238-9.....12	048011-17191-3.....25
021200-20276-6.....46	021200-72407-7.....55	048011-04295-4.....24	048011-13239-6.....12	048011-17459-4.....26
021200-20333-6.....46	021200-76394-6.....68	048011-04297-8.....24	048011-13241-9.....12	048011-18245-2.....41
021200-20854-6.....47	021200-82225-4.....47	048011-04298-5.....24	048011-13242-6.....12	048011-18253-7.....40
021200-21210-9.....45	021200-82236-0.....47	048011-04299-2.....24	048011-13370-6.....29	048011-18254-4.....41
021200-21232-1.....46	021200-82242-1.....45	048011-04303-6.....15	048011-13371-3.....29	048011-18355-8.....16
021200-21305-2.....68	021200-82314-5.....48	048011-04305-0.....15	048011-13372-0.....29	048011-18358-9.....16
021200-21354-0.....46	021200-82618-4.....45	048011-05016-4.....24	048011-13373-7.....29	048011-18424-1.....16
021200-21789-0.....48	021200-83528-5.....48	048011-05019-5.....24	048011-13616-5.....26	048011-18482-1.....16
021200-21791-3.....48	021200-83643-5.....47	048011-05022-5.....24	048011-13617-2.....26	048011-18483-8.....16
021200-22586-4.....46	021200-87191-7.....48	048011-05023-2.....24	048011-13619-6.....26	048011-18485-2.....16
021200-22922-0.....55	021200-89449-7.....47	048011-05132-1.....26	048011-13620-2.....26	048011-18697-9.....40
021200-25340-9.....47	021200-89463-3.....48	048011-05135-2.....26	048011-13639-4.....24	048011-18730-3.....12
021200-26074-2.....52	021200-89464-0.....48	048011-05136-9.....26	048011-13713-1.....25	048011-18732-7.....12
021200-26075-9.....52	021200-89471-8.....48	048011-05206-9.....39	048011-13743-8.....25	048011-18733-4.....12
021200-26076-6.....52	021200-89472-5.....48	048011-05207-6.....39	048011-13752-0.....25	048011-18734-1.....12
021200-26077-3.....52	021200-89473-2.....48	048011-05227-4.....24	048011-13753-7.....25	048011-18736-5.....12
021200-26078-0.....52	021200-96315-5.....45	048011-05228-1.....24	048011-13766-7.....25	048011-18737-2.....12
021200-30023-3.....45	021200-96316-2.....45	048011-05523-7.....12	048011-13800-8.....29	048011-22970-6.....6
021200-30088-2.....46	021200-96327-8.....68	048011-05527-5.....12	048011-13802-2.....29	048011-22971-3.....6
021200-31310-3.....47	021200-96596-8.....68	048011-05528-2.....12	048011-13803-9.....29	048011-22972-0.....6
021200-31311-0.....47	048011-00264-4.....39	048011-05530-5.....12	048011-13928-9.....29	048011-23464-4.....67
021200-37629-0.....53	048011-00265-1.....39	048011-05531-2.....12	048011-13968-5.....14	048011-23465-1.....67
021200-37630-6.....53	048011-00266-8.....39	048011-05532-9.....12	048011-14002-0.....68	048011-23479-8.....67
021200-41121-2.....53	048011-00270-5.....39	048011-05643-2.....24	048011-14063-6.....25	048011-23480-4.....67
021200-42979-8.....53	048011-00274-3.....39	048011-05680-7.....15	048011-14099-5.....15	048011-23483-5.....67
021200-43352-8.....53	048011-00275-0.....39	048011-05741-5.....24	048011-14100-8.....15	048011-23484-2.....67
021200-43353-5.....53	048011-00276-7.....39	048011-05783-5.....24	048011-14101-5.....15	048011-25764-8.....12
021200-43354-2.....53	048011-00568-3.....24	048011-05790-3.....26	048011-14105-3.....40	048011-25765-5.....12
021200-43355-9.....53	048011-00579-9.....24	048011-05791-0.....26	048011-14111-4.....15	048011-25766-2.....12

## UPC Index (Continued)

048011-25767-9.....12	051111-49938-2.....9	051111-50769-8.....8	051111-60327-7.....36	051131-05913-9.....66
048011-25770-9.....12	051111-49939-9.....9	051111-50770-4.....8	051111-60328-4.....36	051131-05916-0.....66
048011-25773-0.....12	051111-49940-5.....9	051111-50771-1.....8	051111-60329-1.....36	051131-05919-1.....66
048011-25774-7.....12	051111-49941-2.....9	051111-50772-8.....8	051111-60330-7.....36	051131-06539-0.....54
048011-25775-4.....12	051111-49942-9.....9	051111-50774-2.....8	051111-60331-4.....36	051131-06718-9.....54
048011-25780-8.....12	051111-49943-6.....9	051111-50775-9.....8	051111-60332-1.....36	051131-06976-8.....55
048011-27603-8.....29	051111-49949-8.....10	051111-50776-6.....8	051111-60333-8.....36	051131-06982-4.....55
048011-27605-2.....29	051111-50253-2.....10	051111-50777-3.....8	051111-60334-5.....36	051131-06984-8.....55
048011-27606-9.....29	051111-50254-9.....10	051111-51033-9.....9	051111-60342-0.....36	051131-06995-4.....55
048011-27671-7.....15	051111-50409-3.....4	051111-51034-6.....9	051111-60343-7.....36	051131-07000-9.....60
048011-27672-4.....15	051111-50410-9.....4	051111-51039-1.....9	051111-60344-4.....36	051131-07024-5.....58
048011-27673-1.....15	051111-50411-6.....4	051111-51045-2.....7	051111-60345-1.....36	051131-07025-2.....58
048011-27674-8.....15	051111-50412-3.....4	051111-51046-9.....7	051111-60346-8.....36	051131-07026-9.....58
048011-27675-5.....15	051111-50413-0.....4	051111-51047-6.....6	051111-60347-5.....36	051131-07047-4.....60
048011-27676-2.....15	051111-50414-7.....4	051111-51159-6.....7	051111-60348-2.....36	051131-07184-6.....60
048011-27677-9.....15	051111-50415-4.....4	051111-51160-2.....7	051111-60349-9.....36	051131-07189-1.....57
048011-27678-6.....15	051111-50416-1.....4	051111-51161-9.....7	051111-60350-5.....36	051131-07521-4.....39
048011-27679-3.....15	051111-50420-8.....4	051111-51162-6.....7	051111-60352-9.....36	051131-07522-1.....39
048011-27745-5.....14	051111-50421-5.....4	051111-51163-3.....7	051111-60686-5.....36	051131-37021-5.....56
048011-27746-2.....14	051111-50422-2.....4	051111-51164-0.....7	051111-60687-2.....36	051131-37022-2.....56
048011-27747-9.....14	051111-50425-3.....4	051111-51199-2.....22	051111-60688-9.....36	051131-37062-8.....63
048011-27748-6.....14	051111-50426-0.....4	051111-51200-5.....23	051111-60689-6.....36	051131-37063-5.....63
048011-27749-3.....14	051111-50427-7.....4	051111-51201-2.....23	051111-60690-2.....36	051131-37081-9.....59
048011-33013-6.....41	051111-50428-4.....4	051111-51202-9.....23	051111-60691-9.....36	051131-37082-6.....59
048011-33136-2.....20	051111-50429-1.....4	051111-51206-7.....23	051111-60692-6.....36	051131-37083-3.....59
048011-33137-9.....20	051111-50430-7.....4	051111-51207-4.....22	051111-60693-3.....36	051131-37113-7.....65
048011-33138-6.....20	051111-50440-6.....7	051111-51209-8.....22	051111-60694-0.....36	051131-37114-4.....65
048011-33139-3.....20	051111-50442-0.....7	051111-51210-4.....23	051111-60696-4.....36	051131-37115-1.....65
048011-33140-9.....20	051111-50443-7.....7	051111-51212-8.....22	051111-60697-1.....36	051131-37116-8.....65
048011-33162-1.....23	051111-50444-4.....7	051111-51213-5.....22	051111-60698-8.....36	051131-46465-8.....61
048011-33163-8.....23	051111-50445-1.....7	051111-51214-2.....22	051111-60699-5.....36	051131-52850-0.....63
048011-33164-5.....23	051111-50446-8.....7	051111-55694-2.....4	051111-60700-8.....36	051131-52967-5.....56
048011-33165-2.....23	051111-50447-5.....7	051111-55739-6.....4	051111-60701-5.....36	051131-54145-8.....59
048011-33166-9.....23	051111-50448-2.....7	051111-55740-2.....4	051111-60702-2.....36	051131-54146-5.....59
048011-33167-6.....23	051111-50450-5.....18	051111-55741-9.....4	051111-60703-9.....36	051131-54159-5.....59
048011-33168-3.....23	051111-50451-2.....18	051111-55742-6.....4	051111-60704-6.....36	051138-21526-7.....64
048011-33169-0.....23	051111-50452-9.....18	051111-55743-3.....4	051111-60705-3.....36	051138-21527-4.....64
048011-33170-6.....23	051111-50453-6.....18	051111-55746-4.....4	051111-60707-7.....36	051138-21674-5.....60
048011-33171-3.....23	051111-50454-3.....18	051111-55751-8.....4	051111-60708-4.....36	051138-28911-4.....64
048011-33174-4.....26	051111-50455-0.....18	051111-55752-5.....4	051111-60709-1.....36	051138-29002-3.....64
048011-33182-9.....26	051111-50459-8.....18	051111-55753-2.....11	051111-60710-7.....36	051138-29008-0.....63
048011-33184-3.....26	051111-50460-4.....18	051111-55754-9.....11	051111-60711-4.....36	051138-29009-7.....63
048011-33185-0.....26	051111-50461-1.....18	051111-55755-6.....11	051111-60712-1.....36	051138-29071-9.....64
048011-34819-3.....67	051111-50462-8.....18	051111-55756-3.....11	051111-60713-8.....36	051138-29333-3.....64
048011-34820-9.....67	051111-50463-5.....18	051111-55767-9.....5	051111-60714-5.....36	051138-29334-0.....64
048011-34821-6.....67	051111-50464-2.....18	051111-55776-1.....5	051111-60715-2.....36	051138-37103-8.....65
048011-34822-3.....67	051111-50467-3.....8	051111-55779-2.....5	051111-60716-9.....36	051138-46457-3.....56
048011-34823-0.....67	051111-50468-0.....8	051111-55780-8.....5	051111-60718-3.....36	051138-46467-2.....61
048011-34824-7.....67	051111-50469-7.....8	051111-55958-1.....7	051111-69017-8.....22	051138-54141-0.....57
048011-34826-1.....67	051111-50470-3.....8	051111-55959-8.....7	051111-69068-0.....23	051138-54186-1.....60
048011-34827-8.....67	051111-50471-0.....8	051111-55960-4.....7	051111-69073-4.....23	051138-54187-8.....61
048011-34828-5.....67	051111-50472-7.....8	051111-55961-1.....7	051111-69075-8.....23	051138-54257-3.....59
048011-34829-2.....67	051111-50473-4.....8	051111-55965-9.....4	051111-69077-2.....23	051138-54258-0.....59
048011-34830-8.....67	051111-50474-1.....8	051111-55966-6.....4	051111-69078-9.....23	051138-54259-7.....59
048011-34831-5.....67	051111-50475-8.....8	051111-55967-3.....4	051111-69080-2.....23	051138-54285-1.....57
051111-49608-4.....8	051111-50743-8.....11	051111-55968-0.....4	051131-01229-5.....17	051138-54343-8.....56
051111-49609-1.....8	051111-50744-5.....11	051111-55969-7.....4	051131-01231-8.....17	051138-66003-6.....63
051111-49610-7.....8	051111-50745-2.....11	051111-55970-3.....4	051131-01232-5.....17	051138-66004-3.....63
051111-49611-4.....8	051111-50748-3.....11	051111-55971-0.....5	051131-01233-2.....17	051138-66068-5.....61
051111-49613-8.....8	051111-50749-0.....11	051111-55972-7.....5	051131-01234-9.....17	051138-66069-2.....61
051111-49614-5.....8	051111-50750-6.....11	051111-55973-4.....5	051131-01235-6.....17	051138-66070-8.....61
051111-49615-2.....8	051111-50751-3.....11	051111-55974-1.....5	051131-01236-3.....17	051138-66192-7.....57
051111-49616-9.....8	051111-50752-0.....11	051111-55975-8.....5	051131-01237-0.....17	051138-76800-8.....65
051111-49617-6.....8	051111-50753-7.....11	051111-55989-5.....7	051131-01985-0.....28	051138-76801-5.....65
051111-49932-0.....9	051111-50754-4.....11	051111-55990-1.....7	051131-01986-7.....28	051144-01330-2.....19
051111-49933-7.....9	051111-50755-1.....11	051111-55991-8.....7	051131-01989-8.....28	051144-01331-9.....19
051111-49934-4.....9	051111-50756-8.....11	051111-55992-5.....7	051131-01990-4.....28	051144-01332-6.....19
051111-49936-8.....9	051111-50757-5.....11	051111-60325-3.....36	051131-01994-2.....28	051144-01333-3.....19
051111-49937-5.....9	051111-50758-2.....11	051111-60326-0.....36	051131-05912-2.....66	051144-01334-0.....19

## UPC Index (Continued)

051144-01335-7.....19	051144-11423-8.....10	051144-14624-6.....27	051144-22354-1.....11	051144-33639-5.....21
051144-02002-7.....37	051144-11425-2.....10	051144-14625-3.....27	051144-22392-3.....9	051144-33640-1.....21
051144-02003-4.....37	051144-11427-6.....10	051144-14655-0.....27	051144-22393-0.....9	051144-33667-8.....21
051144-02004-1.....37	051144-11428-3.....10	051144-14656-7.....27	051144-22394-7.....9	051144-35086-5.....27
051144-02005-8.....37	051144-11448-1.....10	051144-14657-4.....27	051144-22395-4.....9	051144-35088-9.....27
051144-02006-5.....37	051144-11449-8.....10	051144-14660-4.....10	051144-22396-1.....9	051144-35109-1.....27
051144-02007-2.....37	051144-11450-4.....10	051144-14661-1.....10	051144-22397-8.....9	051144-35111-4.....27
051144-02014-0.....37	051144-11453-5.....10	051144-14667-3.....20	051144-22398-5.....9	051144-35112-1.....27
051144-02015-7.....37	051144-11455-9.....10	051144-14756-4.....20	051144-22399-2.....9	051144-35113-8.....27
051144-02016-4.....37	051144-11973-8.....34	051144-14884-4.....22	051144-22400-5.....9	051144-35467-2.....27
051144-02017-1.....37	051144-11976-9.....34	051144-14895-0.....22	051144-22401-2.....9	051144-35468-9.....27
051144-02018-8.....37	051144-11977-6.....34	051144-14896-7.....22	051144-22402-9.....9	051144-35469-6.....27
051144-02103-1.....37	051144-11978-3.....34	051144-20798-5.....19	051144-22403-6.....9	051144-35475-7.....27
051144-02104-8.....37	051144-11980-6.....34	051144-20801-2.....19	051144-22404-3.....9	051144-35476-4.....27
051144-02112-3.....37	051144-11981-3.....34	051144-20802-9.....19	051144-22405-0.....9	051144-35477-1.....27
051144-02113-0.....37	051144-11990-5.....34	051144-20868-5.....19	051144-22406-7.....9	051144-40172-7.....34
051144-02114-7.....37	051144-11991-2.....34	051144-20870-8.....19	051144-22407-4.....9	051144-40174-1.....34
051144-02115-4.....37	051144-11994-3.....34	051144-20871-5.....19	051144-22408-1.....9	051144-40175-8.....34
051144-02116-1.....37	051144-12500-5.....36	051144-20873-9.....19	051144-22409-8.....9	051144-40178-9.....34
051144-02117-8.....37	051144-12501-2.....36	051144-20874-6.....19	051144-26309-7.....21	051144-40183-3.....34
051144-02118-5.....37	051144-12954-6.....10	051144-20876-0.....19	051144-26312-7.....21	051144-40184-0.....34
051144-02119-2.....37	051144-12955-3.....10	051144-20877-7.....19	051144-26316-5.....21	051144-40187-1.....34
051144-02402-5.....36	051144-12956-0.....10	051144-20878-4.....19	051144-26320-2.....21	051144-40192-5.....34
051144-02431-5.....36	051144-12957-7.....10	051144-20879-1.....19	051144-26388-2.....21	051144-40193-2.....34
051144-02432-2.....36	051144-13325-3.....6	051144-20881-4.....19	051144-26396-7.....21	051144-40196-3.....34
051144-02433-9.....36	051144-13533-2.....21	051144-20883-8.....19	051144-26400-1.....21	051144-40197-0.....34
051144-05000-0.....36	051144-13627-8.....16	051144-20884-5.....19	051144-26404-9.....21	051144-40200-7.....34
051144-05001-7.....36	051144-13714-5.....21	051144-20885-2.....19	051144-26408-7.....21	051144-40201-4.....34
051144-05002-4.....36	051144-13715-2.....21	051144-20886-9.....19	051144-26424-7.....21	051144-40202-1.....34
051144-05020-8.....36	051144-13873-9.....9	051144-20887-6.....19	051144-26426-1.....21	051144-40203-8.....34
051144-05021-5.....36	051144-13926-2.....5	051144-20888-3.....19	051144-26436-0.....21	051144-40205-2.....34
051144-05022-2.....36	051144-13928-6.....5	051144-20889-0.....19	051144-26438-4.....21	051144-40207-6.....34
051144-05040-6.....36	051144-13930-9.....5	051144-20890-6.....19	051144-26440-7.....21	051144-40208-3.....34
051144-05041-3.....36	051144-13931-6.....5	051144-20891-3.....19	051144-26441-4.....21	051144-40210-6.....34
051144-05042-0.....36	051144-13932-3.....5	051144-20907-1.....19	051144-26443-8.....21	051144-40211-3.....34
051144-05510-4.....19	051144-13933-0.....5	051144-20908-8.....19	051144-26513-8.....21	051144-40214-4.....34
051144-05575-3.....18	051144-13934-7.....5	051144-20909-5.....19	051144-26515-2.....21	051144-40219-9.....34
051144-05576-0.....18	051144-13936-1.....5	051144-20910-1.....19	051144-26517-6.....21	051144-40220-5.....34
051144-05620-0.....6	051144-13937-8.....5	051144-20911-8.....19	051144-26560-2.....21	051144-40221-2.....34
051144-05621-7.....6	051144-14021-3.....32	051144-20913-2.....19	051144-26561-9.....21	051144-40224-3.....34
051144-05622-4.....6	051144-14022-0.....32	051144-21497-6.....19	051144-26562-6.....21	051144-40225-0.....34
051144-11000-1.....9	051144-14023-7.....32	051144-21639-0.....19	051144-26564-0.....21	051144-40227-4.....34
051144-11100-8.....10	051144-14024-4.....32	051144-21731-1.....19	051144-26568-8.....21	051144-40228-1.....34
051144-11101-5.....10	051144-14026-8.....32	051144-21746-5.....18	051144-26571-8.....21	051144-40241-0.....34
051144-11102-2.....10	051144-14027-5.....32	051144-21747-2.....18	051144-26597-8.....21	051144-40243-4.....34
051144-11103-9.....10	051144-14028-2.....32	051144-21748-9.....18	051144-26599-2.....21	051144-40252-6.....34
051144-11104-6.....10	051144-14032-9.....32	051144-21749-6.....18	051144-26601-2.....21	051144-40267-0.....34
051144-11105-3.....10	051144-14033-6.....32	051144-21750-2.....18	051144-26602-9.....21	051144-40270-0.....34
051144-11106-0.....10	051144-14034-3.....32	051144-21751-9.....18	051144-26614-2.....21	051144-40274-8.....34
051144-11107-7.....10	051144-14197-5.....13	051144-21752-6.....18	051144-26715-6.....20	051144-45032-9.....27
051144-11108-4.....10	051144-14198-2.....13	051144-21761-8.....18	051144-26716-3.....20	051144-45033-6.....27
051144-11109-1.....10	051144-14201-9.....13	051144-21762-5.....18	051144-26717-0.....20	051144-45034-3.....27
051144-11110-7.....10	051144-14202-6.....13	051144-21789-2.....17	051144-26719-4.....20	051144-45035-0.....27
051144-11111-4.....10	051144-14211-8.....13	051144-21790-8.....17	051144-26720-0.....20	051144-45068-8.....19
051144-11112-1.....10	051144-14212-5.....13	051144-21791-5.....17	051144-26723-1.....20	051144-45070-1.....19
051144-11113-8.....10	051144-14215-6.....13	051144-21792-2.....17	051144-26725-5.....20	051144-45091-6.....13
051144-11137-4.....9	051144-14216-3.....13	051144-21793-9.....17	051144-26732-3.....20	051144-45092-3.....13
051144-11253-1.....21	051144-14270-5.....6	051144-21794-6.....17	051144-26733-0.....20	051144-45095-4.....13
051144-11255-5.....21	051144-14519-5.....20	051144-21795-3.....17	051144-26778-1.....20	051144-45096-1.....13
051144-11411-5.....9	051144-14534-8.....22	051144-21796-0.....17	051144-26780-4.....20	051144-45099-2.....13
051144-11412-2.....9	051144-14557-7.....21	051144-21797-7.....17	051144-26856-6.....20	051144-45100-5.....13
051144-11414-6.....9	051144-14559-1.....9	051144-21798-4.....17	051144-26857-3.....20	051144-45101-2.....13
051144-11415-3.....9	051144-14575-1.....27	051144-21799-1.....17	051144-26892-4.....20	051144-45102-9.....13
051144-11416-0.....9	051144-14576-8.....27	051144-21800-4.....17	051144-26894-8.....20	051144-45117-3.....33
051144-11417-7.....9	051144-14577-5.....27	051144-22349-7.....11	051144-31170-5.....20	051144-45118-0.....33
051144-11418-4.....9	051144-14607-9.....27	051144-22350-3.....11	051144-31823-0.....21	051144-45119-7.....33
051144-11419-1.....9	051144-14608-6.....27	051144-22351-0.....11	051144-32375-3.....20	051144-45121-0.....36
051144-11420-7.....9	051144-14609-3.....27	051144-22352-7.....11	051144-33067-6.....21	051144-45123-4.....35
051144-11421-4.....9	051144-14623-9.....27	051144-22353-4.....11	051144-33638-8.....21	051144-45124-1.....35

## UPC Index (Continued)

051144-45127-2.....35	051144-76806-6.....9	051144-80771-0.....34	051144-84304-6.....20	051144-88876-4.....19
051144-45129-6.....35	051144-76807-3.....9	051144-80773-4.....34	051144-84306-0.....20	051144-88877-1.....19
051144-45130-2.....35	051144-76810-3.....9	051144-80774-1.....34	051144-84307-7.....20	051144-88878-8.....19
051144-45131-9.....35	051144-76811-0.....9	051144-80775-8.....34	051144-84315-2.....22	051144-88880-1.....19
051144-45132-6.....35	051144-77065-6.....20	051144-80782-6.....34	051144-84404-3.....20	051144-88882-5.....19
051144-45138-8.....35	051144-77115-8.....9	051144-80783-3.....34	051144-84409-8.....20	051144-88886-3.....19
051144-45139-5.....35	051144-77116-5.....9	051144-80786-4.....33	051144-84412-8.....20	051144-88887-0.....19
051144-45144-9.....35	051144-77152-3.....22	051144-80787-1.....33	051144-84416-6.....22	051144-88889-4.....19
051144-45145-6.....35	051144-77280-3.....20	051144-80788-8.....33	051144-85015-0.....22	051144-88890-0.....19
051144-45152-4.....35	051144-77333-6.....20	051144-80790-1.....33	051144-85096-9.....16	051144-88901-3.....19
051144-45153-1.....35	051144-77334-3.....20	051144-80792-5.....33	051144-85105-8.....16	051144-88902-0.....19
051144-45156-2.....35	051144-77336-7.....20	051144-80796-3.....33	051144-85320-5.....20	051144-88903-7.....19
051144-45159-3.....35	051144-77408-1.....20	051144-80799-4.....30	051144-85377-9.....22	051144-88904-4.....19
051144-45179-1.....13	051144-77476-0.....20	051144-80801-4.....30	051144-85384-7.....22	051144-88905-1.....19
051144-45190-6.....6	051144-77491-3.....20	051144-80942-4.....17	051144-85762-3.....22	051144-88906-8.....19
051144-45205-7.....6	051144-77512-5.....22	051144-80943-1.....17	051144-85769-2.....22	051144-96959-3.....32
051144-56563-6.....5	051144-77642-9.....20	051144-80944-8.....17	051144-85883-5.....11	051144-96961-6.....32
051144-72227-3.....20	051144-77643-6.....20	051144-80945-5.....17	051144-85884-2.....11	051144-96963-0.....32
051144-72228-0.....20	051144-77663-4.....22	051144-80946-2.....17	051144-85885-9.....11	051144-96968-5.....32
051144-72229-7.....20	051144-77717-4.....35	051144-80947-9.....17	051144-85886-6.....11	051144-96969-2.....32
051144-74025-3.....21	051144-77718-1.....35	051144-81064-2.....20	051144-85890-3.....11	051144-96971-5.....32
051144-74207-3.....21	051144-77720-4.....35	051144-81443-5.....22	051144-85959-7.....4	051144-96973-9.....32
051144-74209-7.....21	051144-77721-1.....35	051144-81687-3.....22	051144-85960-3.....4	051144-97008-7.....32
051144-74324-7.....21	051144-77722-8.....35	051144-81732-0.....6	051144-85961-0.....4	051144-97013-1.....32
051144-74325-4.....21	051144-77728-0.....13	051144-81733-7.....6	051144-85962-7.....4	051144-97015-5.....32
051144-74354-4.....21	051144-77729-7.....13	051144-81734-4.....6	051144-85963-4.....4	051144-97017-9.....32
051144-76429-7.....9	051144-77825-6.....22	051144-81752-8.....21	051144-85966-5.....4	051144-97041-4.....32
051144-76433-4.....10	051144-77992-5.....20	051144-81767-2.....22	051144-85967-2.....4	051144-97042-1.....32
051144-76436-5.....10	051144-80028-5.....22	051144-81984-3.....27	051144-85968-9.....4	051144-97044-5.....32
051144-76514-0.....22	051144-80176-3.....22	051144-81986-7.....27	051144-85969-6.....4	051144-97046-9.....32
051144-76515-7.....22	051144-80232-6.....20	051144-82022-1.....22	051144-85970-2.....4	051144-97059-9.....32
051144-76519-5.....22	051144-80253-1.....20	051144-82153-2.....22	051144-85973-3.....4	051144-97162-6.....32
051144-76520-1.....22	051144-80286-9.....22	051144-82229-4.....20	051144-85974-0.....4	051144-97163-3.....32
051144-76527-0.....22	051144-80486-3.....20	051144-82231-7.....22	051144-85975-7.....4	051144-97165-7.....32
051144-76531-7.....22	051144-80508-2.....10	051144-82238-6.....28	051144-85976-4.....4	051144-97166-4.....32
051144-76532-4.....22	051144-80509-9.....10	051144-82244-7.....9	051144-85977-1.....4	051144-97239-5.....32
051144-76533-1.....22	051144-80510-5.....10	051144-82313-0.....22	051144-86468-3.....17	051144-97240-1.....32
051144-76622-2.....10	051144-80511-2.....10	051144-82342-0.....20	051144-86469-0.....17	051144-97242-5.....32
051144-76623-9.....10	051144-80512-9.....10	051144-82770-1.....27	051144-86470-6.....17	051144-97244-9.....32
051144-76624-6.....10	051144-80513-6.....10	051144-82899-9.....41	051144-86471-3.....17	051144-97248-7.....32
051144-76625-3.....10	051144-80514-3.....6	051144-82900-2.....41	051144-86472-0.....17	051144-97249-4.....32
051144-76626-0.....10	051144-80515-0.....6	051144-82901-9.....41	051144-86473-7.....17	051144-97251-7.....32
051144-76627-7.....10	051144-80516-7.....6	051144-83242-2.....13	051144-86474-4.....17	051144-97257-9.....32
051144-76628-4.....10	051144-80551-8.....20	051144-83263-7.....27	051144-86475-1.....17	051144-97259-3.....32
051144-76629-1.....10	051144-80650-8.....27	051144-83265-1.....27	051144-86476-8.....17	051144-97267-8.....32
051144-76630-7.....10	051144-80651-5.....27	051144-83267-5.....27	051144-86477-5.....17	051144-97426-9.....34
051144-76631-4.....10	051144-80652-2.....27	051144-83268-2.....27	051144-86488-1.....17	051144-97428-3.....34
051144-76632-1.....10	051144-80654-6.....5	051144-83269-9.....27	051144-86489-8.....17	051144-97451-1.....34
051144-76633-8.....10	051144-80655-3.....5	051144-83271-2.....27	051144-86490-4.....17	051144-97458-0.....34
051144-76634-5.....10	051144-80656-0.....5	051144-83487-7.....28	051144-86491-1.....17	051144-97464-1.....34
051144-76679-6.....22	051144-80657-7.....5	051144-83488-4.....28	051144-86492-8.....17	051144-97467-2.....34
051144-76680-2.....22	051144-80660-7.....5	051144-83489-1.....13	051144-86493-5.....17	051144-97468-9.....34
051144-76686-4.....22	051144-80661-4.....5	051144-83490-7.....41	051144-86494-2.....17	051144-97470-2.....34
051144-76731-1.....22	051144-80662-1.....5	051144-83522-5.....22	051144-86495-9.....17	051144-97511-2.....34
051144-76733-5.....22	051144-80663-8.....5	051144-83587-4.....10	051144-86496-6.....17	051144-97571-6.....34
051144-76738-0.....22	051144-80665-2.....5	051144-83588-1.....10	051144-86497-3.....17	891040-01450-7.....21
051144-76742-7.....10	051144-80678-2.....30	051144-83589-8.....10	051144-88743-9.....6	891040-01451-4.....21
051144-76743-4.....10	051144-80686-7.....20	051144-83591-1.....10	051144-88755-2.....28	891040-01452-1.....21
051144-76746-5.....10	051144-80753-6.....27	051144-83592-8.....10	051144-88765-1.....7	891040-01453-8.....21
051144-76750-2.....10	051144-80755-0.....27	051144-83690-1.....11	051144-88765-1.....8	891040-01454-5.....21
051144-76751-9.....10	051144-80757-4.....27	051144-83691-8.....11	051144-88769-9.....8	891040-01455-2.....21
051144-76754-0.....10	051144-80759-8.....27	051144-83692-5.....11	051144-88869-6.....19	891040-01456-9.....21
051144-76755-7.....10	051144-80761-1.....27	051144-83693-2.....11	051144-88870-2.....19	891040-01457-6.....21
051144-76778-6.....9	051144-80763-5.....27	051144-83694-9.....11	051144-88871-9.....19	891040-02663-0.....20
051144-76798-4.....9	051144-80765-9.....34	051144-83695-6.....11	051144-88872-6.....19	891040-10454-3.....21
051144-76799-1.....9	051144-80766-6.....34	051144-84296-4.....22	051144-88873-3.....19	891040-10455-0.....21
051144-76802-8.....9	051144-80769-7.....34	051144-84302-2.....20	051144-88874-0.....19	891040-10456-7.....21
051144-76803-5.....9	051144-80770-3.....34	051144-84303-9.....20	051144-88875-7.....19	









## THREE EASY WAYS TO CONTACT US FOR ALL 3M INDUSTRIAL PRODUCTS:

3M can provide additional products and accessories to meet your needs.

Please contact us in any of the following ways that you prefer:

*Contact your local 3M authorized distributor directly. For information on a 3M distributor or sales representative in your area, contact us at the numbers below:*

For the contiguous 48 United States:

Call . . . . . **1-866-279-1288 ext. 8005**

Fax . . . . . **1-877-369-2923**

For:

Alaska . . . . . **907-522-5200**

Canada . . . . . **519-451-2500**

Hawaii . . . . . **808-422-2721**

Northern Mexico . . . . . **915-856-5035**

Puerto Rico . . . . . **787-750-3000**

E-mail us at **3MIndustrial@mmm.com**

For additional 3M product information or material data sheets call **1-800-3M Helps** or visit us at **www.3M.com**

Prices subject to change without notice.

---

### Important Notice to Purchaser

**Safety Information:** Always read and follow all safety information included with the product. Do not exceed maximum operating RPM's. Use guards provided with machine. Follow safety operation procedures posted in work areas.

**Product Use:** All statements, technical information and recommendations contained in this document are based upon tests or experience that 3M believes are reliable. However, many factors beyond 3M's control can effect the use and performance of a 3M product in a particular application, including the conditions under which the product is used and the time and environments conditions in which the product is expected to perform. Since these factors are uniquely within the user's knowledge and control, it is essential that the user evaluate the 3M product to determine whether it is fit for a particular purpose and suitable for the user's method of application.

**Warranty and Limited Remedy:** Unless stated otherwise in 3M's product literature, packaging inserts or product packaging for individual products, 3M warrants that each 3M product meets the applicable specifications at the time 3M ships the product. Individual products may have additional or different warranties as stated on product literature, package inserts or product packages. 3M MAKES NO OTHER WARRANTIES, EXPRESS OR IMPLIED, INCLUDING, BUT NOT LIMITED TO, ANY IMPLIED WARRANTY OF MERCHANTABILITY OR FITNESS FOR A PARTICULAR PURPOSE OR ANY IMPLIED WARRANTY ARISING OUT OF A COURSE OF DEALING, CUSTOM OR USAGE OF TRADE. User is responsible for determining whether the 3M product is fit for a particular purpose and suitable for user's application. If the 3M product is defective within the warranty period, your exclusive remedy and 3M's and seller's sole obligation will be at 3M's option, to replace the product or refund the purchase price.

**Limitation of Liability:** Except where prohibited by law, 3M and seller will not be liable for any loss or damage arising from the 3M product, whether direct, indirect, special, incidental, or consequential, regardless of the legal theory asserted, including warranty, contract, negligence, or strict liability.

---



#### Industrial Business

Customer Response Center  
900 Bush Avenue, Building 21-1W-10  
St. Paul, MN 55106



Minimum 10%  
Post-consumer Fiber

3M, Scotch-Brite, Stikit, Hookit, Roloc, Wetordry, Cubitron, Trizact, Scotch, Tartan, Scotch-Weld, Jet-Weld, Scotch-Grip, EPX, Scotchblok, Cool Flow, Safety-Walk, VHB and Speedglas are all trademarks of 3M.

Printed in U.S.A.  
© 3M 2005 All Rights Reserved  
61-5002-8097-1(255)JR