



Application Tapes

Premasking and Prespacing Tape for Graphic Films

Table of Contents

Product Description	1
Product Line	1
Characteristics	2
3M Products Mentioned in this Bulletin	2
Warranty and Durability	2
Health and Safety	2
Usage Recommendations	3
When to use Premasking Tape	3
When to Use Prespacing Tape	4
Premasking Tape as An Application Aid	5
Premasking Tape in Overpaint Systems	5
Prespacing Tape for Cut Graphics	5
Printing Instructions on Application Tapes	6
Protecting Graphics During Vehicle Refinishing	6
Techniques For Applying Application Tape	7
Shelf Life, Storage, Handling	8
3M Related Literature	9
Bulletin Change Summary	9

Product Description

- What are application tapes?
 - Adhesive-backed translucent material used as an aid in applying graphics.
- What are the typical uses for application tape?
 - Add stiffness to make application easier.
 - Protect the film from stretching during application.
 - Protect the graphic image from scratching during application.
 - Aid in the registration of cut graphic parts.
 - Protect applied graphics from damage during other operations.
- What's the difference between one premasking tape and another, or one prespacing tape and another?
 - Each tape has a different level of adhesion. This ensures that the tape you use has a lower adhesion to the film than the film does to the substrate.
 - Choose the recommended tape for your application to ensure easy removal. See the tables on pages 3 and 4, and the information that follows the tables.
- Which type of tape should be used?
 - This depends on the type of graphic and the last component of the graphic construction. See the Usage Recommendations Tables on pages 3 and 4.

Product Line

- 3M™ Prespacing Tape SCPS-2
- 3M™ Prespacing Tape SCPS-53X
- 3M™ Prespacing Tape SCPS-55
- 3M™ Premasking Tape SCPM-3
- 3M™ Premasking Tape SCPM-19
- 3M™ Premasking Tape SCPM-44X

Characteristics

These are typical values for unprocessed product. Contact your 3M representative for a custom specification.

Characteristic	Value
Tape material	Paper
Thickness	4.5 to 5 mils (0.11 to 0.12 mm)
Adhesive type and color	Pressure sensitive, clear
Adhesion to 3M graphic film	0.39 to 0.77 pounds/inch (69 to 138 g/cm) Note: Each tape has a different adhesion, designed to work with the films, inks and graphic protection as recommended in the base film's Product Bulletin or the Usage Recommendations Table on page 3 and 4.
Tensile strength (minimum)	5 pounds/inch at 73°F (0.9 kg/cm at 23°C)
Service temperature range	Same as the film with which it is used

3M Products Mentioned in this Bulletin

3M™ Scotchcal™ Graphic Film
3M™ Controltac™ Graphic Film
3M™ Controltac™ Graphic Film with Comply™ Adhesive
3M™ Controltac™ Graphic Film with Comply™ v3 Adhesive
3M™ Scotchlite™ Reflective Films
3M™ Piezo Inkjet Inks
3M™ Screen Printing Inks
3M™ Scotchlite™ Screen Printing Inks
3M™ Prespacing Tape
3M™ Premasking Tape

Warranty and Durability

Warranty and Limited Remedy

This product is covered by the 3M Basic Product Warranty.

The following is made in lieu of all other express or implied warranties, including any implied warranty of **merchantability** or fitness for a particular purpose or implied warranty arising out of a course of dealing, custom or usage of trade: all 3M products are warranted to be free of defects in materials and manufacture at the time of shipment and to meet the specifications stated in this Product Bulletin. 3M will replace or refund the price of any 3M materials that do not meet this warranty within the specified time periods. These remedies are exclusive. **In no case shall 3M be liable for any direct, indirect, or consequential damages, including any labor or non-3M materials charges.**

See the *3M Graphics Market Center Warranty Brochure* at 3Mgraphics.com, which gives the terms, additional limitations of the warranty, if any, and limitations of liability.

Health and Safety



When handling any chemical products, read the manufacturers' container labels and the Material Safety Data Sheets (MSDS) for important health, safety and environmental information. To obtain MSDS sheets for 3M products go to 3M.com/MSDS, or by mail or in case of an emergency, call 1-800-364-3577 or 1-651-737-6501.

When using any equipment, always follow the manufacturers' instructions for safe operation.

Usage Recommendations

Application tape is not required for all films or types of applications and it is specifically not recommended for certain film or applications. Refer to the most current Product and Instruction Bulletins for information on specific constructions and end use recommendations.

The type of premasking or prespacing tape to use depends on the type of graphic produced and the last component (ink, overlaminate or clear) that was applied to the graphic construction.

Refer to pages 5 - 8 for application.

When to Use Premasking Tape

- Use as an application aid to increase stiffness, and prevent stretching and damage during application (see Premasking Tape as an Application Aid, page 5).
- Use when little or no liner is exposed.
- Use to protect the graphic when used in combination with spray painted clears (see Premasking Tape Used in Overpaint Systems, page 5).

PREMASKING TAPE

TABLE 1
FILMS, UNPRINTED:
with or without Comply Adhesive
OVERLAMINATES

If this was the Last Applied Component	Use this Premasking Tape
<ul style="list-style-type: none"> • Most unprinted films • Most overlaminates 	SCPM-3
<ul style="list-style-type: none"> • Film 190 	SCPM-19
<ul style="list-style-type: none"> • Film 7725SE 	See PB 7725SE
<ul style="list-style-type: none"> • Thick overlaminates <ul style="list-style-type: none"> - 3645 - 3647 - 3648 	Not required
<ul style="list-style-type: none"> • Specialty overlaminates <ul style="list-style-type: none"> - 8914 - 8518 - 8524 • Film IJ8624 	Do NOT use premasking tape

TABLE 2
SOLVENT INKS and CLEARS

<ul style="list-style-type: none"> • All 3M solvent inks, uncleared • Most solvent clears <ul style="list-style-type: none"> - 1920DR - 1930 - 8530 	SCPM-3
<ul style="list-style-type: none"> • Clear 8920 • Film 3545C with any recommended clear 	SCPM-44X

TABLE 3
UV INKS and CLEARS

<ul style="list-style-type: none"> • All 3M UV inkjet inks, uncleared • Ink series 9800, uncleared • All UV clears <ul style="list-style-type: none"> - 9800CL - 9720UV - 9730UV - 9720i 	SCPM-44X
--	----------

When to Use
Prespacing Tape

- Hold cut and weeded letters or graphics in registration after removing the film liner (see Prespacing Tape for Cut Graphics, page 5).
- Protect cut graphic parts from scratching or damage during application.
- Use when large amounts of liner are exposed.

PRESPACING TAPE

TABLE 4
FILMS, UNPRINTED
without Comply Adhesive
OVERLAMINATES

If this was the Last Applied Component	Use this Prespacing Tape
<ul style="list-style-type: none"> • Most films • Most overlaminates 	SCPS-2
<ul style="list-style-type: none"> • Film 7725SE 	See PB 7725SE
<ul style="list-style-type: none"> • Changeable films <ul style="list-style-type: none"> - 3500C, 3552C - IJ3552C, IJ3555 FN3552C, FN3555, RG3552C, RG3555 - 8522 - 8652C, 8655C - IJ46, IJ63 	Do NOT use changeable films for prespaced graphics
<ul style="list-style-type: none"> • Thick overlaminates <ul style="list-style-type: none"> - 3645 - 3647 - 3648 • Specialty overlaminates <ul style="list-style-type: none"> - 8914 - 8518 - 8524 - 8908 - 8909 • Film IJ8624 	Do NOT use these products for prespaced graphics

TABLE 5
FILMS, PRINTED OR UNPRINTED
with Comply Adhesive
with / without Graphic Protection

<ul style="list-style-type: none"> • All films with Comply adhesive 	SCPS-55
--	---------

TABLE 6
FILMS, PRINTED
without Comply Adhesive and
with SOLVENT INKS and CLEARS

<ul style="list-style-type: none"> • All 3M solvent inks, uncleared • Most solvent clears <ul style="list-style-type: none"> - 1920DR - 1930 - 8530 	SCPS-2
<ul style="list-style-type: none"> • Clear 8920 	SCPS-53X

TABLE 7
UV INKS and CLEARS

<ul style="list-style-type: none"> • All 3M UV inks, uncleared • All UV clears <ul style="list-style-type: none"> - 9800CL - 9720UV - 9730UV - 9720i 	SCPS-53X
---	----------

Application Tape as An Application Aid

An application tape can reduce stretching, wrinkling and air entrapment during hand application of the graphic film to the substrate. The tape increases the stiffness of the graphic, which makes the graphic easier to handle.

An application tape is typically recommended when the graphic meets at least one of these criteria:

- Graphic constructions less than 4 mils thick (film or film and overlamine).
- Graphics that are four square feet or larger.
- Striping or intricately-cut graphics.
- Vinyl films printed with solvent-based inkjet inks.
- Graphics applied at high temperatures.

Important Note!

Do not use an application tape on textured substrates. The graphic may not have enough initial adhesion to the substrate for the application tape to be removed without lifting the graphic.

Premasking Tape in Overpaint Systems

Application tape can protect the graphic from staining when overpainted with most finish paints. This allows you to apply premasked graphics to the prime coat and then apply the finish coat around the graphic. This method effectively edge seals the graphic by embedding the graphic in the paint. The application tape should be removed while the paint is still tacky, but not wet.

Refer to Instruction Bulletin 5.4 for complete details.



The customer should test premasked graphics to ensure that the graphic is protected from the paint and that the premasking can be removed without damaging or lifting the graphic.

Prespacing Tape for Cut Graphics

About Removing Film from Liners

Applying an application tape to prespaced cut graphic parts eliminates the time-consuming layout of individual parts on the application surface.

Graphic film with Comply adhesive, or Controltac graphic films: Do NOT remove these films from their liners and then attempt to reapply the film to the liner. The liners on these films play an important role in how the films apply to a substrate. Key application features will be lost if you prematurely remove the liner.

For films with Comply adhesive where there is liner exposed, use only prespacing tape SCPS-55. Other application tapes will not adhere.

Procedure for Prespacing Graphics

1. Follow the recommended cutting sizes found in each film's Product Bulletin.
2. Make the cut only through film and adhesive. Refer to Instruction Bulletin 4.1 for specific recommendations.
3. Weed (remove) the background material that will not be used in the graphic.

Note: Use caution to avoid lifting very narrow characters from the liner.

4. Apply the appropriate application tape specified in the Usage Recommendations Table. See the Techniques for Applying Application Tape section later in this bulletin for more specific instructions.
5. Trim the graphic to size.

Note: Always check for ease of part pick up before releasing the job. This is particularly important if the cut graphics include small letters, narrow stroke letters or intricate designs with narrow stroke widths or if applying prespacing tape to an exposed liner of a film with Comply adhesive.

6. If the prespacing tape does not adequately pick up the cut graphic parts or adhere well to the liner, a heat lamp vacuum applicator may be required. Process the graphic with its prespacing tape in a heat lamp vacuum applicator at 150°-180°F (66°- 82°C). The duration of this process is dependent upon the type of equipment used. Typically, a two-minute cycle with little or no dwell time at the peak temperature will provide satisfactory results.

- If the prespacing tape does not remove all of the prespaced cut graphic parts easily from the liner, reapply the tape using a squeegee to secure the elements back to the liner. Then gently pull the graphic, liner-side down, over the corner edge of a surface. This helps loosen any imbedded kiss cut edges. See FIGURE 1.

FIGURE 1
Loosening Prespaced Graphics
from a Liner

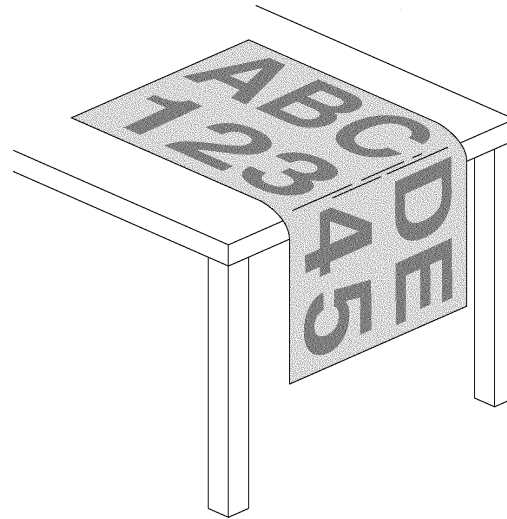

CG-251A

Printing Instructions on Application Tapes

The surface of the application tape can be printed with application instructions and registry marks that aid in positioning and application. These tapes have been successfully printed using the following methods: screen printing, hand printing/stamping, and press printing. Check with an ink manufacturer for assistance in selecting and using an ink for printing application tape. 3M does not provide an ink for this use.

Refer to the ink container labels and the ink manufacturer's Material Safety Data Sheet for health, safety and handling information.

One recommended supplier is Nazdar Inc. at 800-767-9942 or www.nazdar.com (website includes MSDS sheets).

Screen Printing

- Screen print using NazDar® 9700 air dry ink or an equivalent. Use a 200 to 305 tpi (threads per inch) screen or equivalent.
- Rack and air dry for 30 minutes.

Hand Printing

Hand stamp using the NazDar 4411 black ink or equivalent.

Press Printing

Use a fast drying halftone black. Avoid heavy ink laydown.

Protecting Graphics During Vehicle Refinishing

To protect existing 3M graphics when a vehicle is being refinished, use the application tape recommended in the Usage Recommendations Table for the last applied component of the vehicle's existing graphic.

- Cover the graphic with a slightly oversized piece of application tape.
- Cut carefully around the edges with a sharp razor blade.
- Remove the excess tape.
- Apply the paint.
- Remove application tape while paint is still tacky, but not wet.

Techniques For Applying Application Tape

Preparation of Printed Graphics Before Applying Application Tape

Be sure that printed graphics are thoroughly dried or cured before applying application tape. For specific recommendations, see the Instruction Bulletin for the inks being used.

If sheets must be stacked, wrap the stacks with polyethylene and seal to minimize moisture absorption or loss during storage and handling. This can prevent uneven moisture absorption or loss, both of which results in the edges of the sheets waving or curling.

Cutting Films with Application Tape

Certain precautions should be noted when cutting. For specific recommendations see Instruction Bulletin 4.1.

Hand Premasking Procedure

1. Lay an appropriately-sized piece of application tape adhesive-side-up on a table. See FIGURE 2.

FIGURE 2
Lay the Application Tape Adhesive Side Up

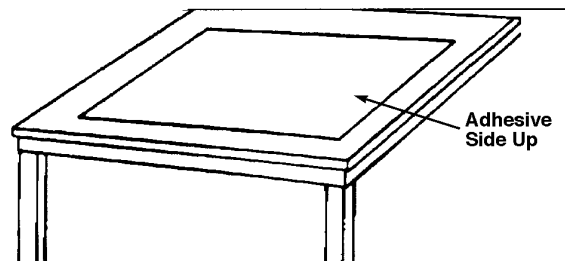

2. Align the graphic face-down on the application tape adhesive. See FIGURE 3.

FIGURE 3
Align the Graphic Face Down

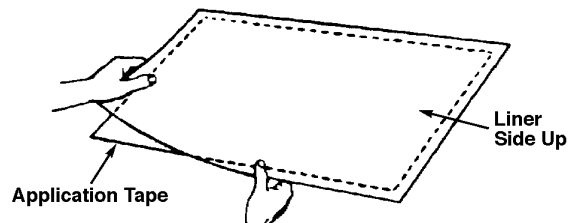

3. Squeegee the graphic from the liner side to adhere the application tape. Work from the center out. See FIGURE 4.

FIGURE 4
Squeegee the Graphic and Application Tape

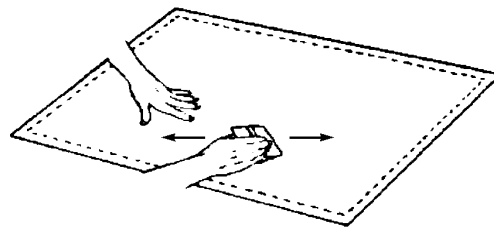

4. Flip the entire graphic/application tape assembly over and squeegee the application tape side. Again, work from the center out.
5. Trim the graphic to size or cut it to shape. See Cutting Films with Application Tape.

Mechanical Lamination

Numerous laminators are available. FIGURE 5 provides two examples. Follow the manufacturer's operating and safety procedures.



When using any equipment, always follow the manufacturers' instructions for safe operation.

FIGURE 5
Examples of Mechanical Equipment

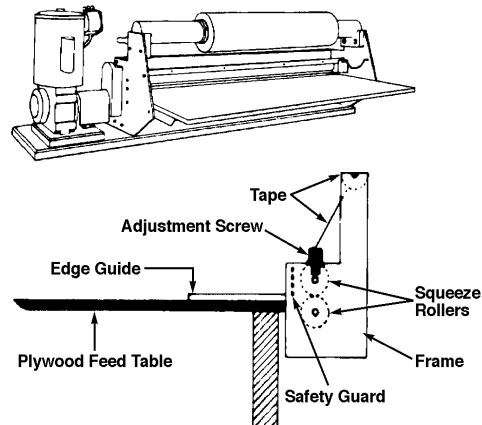

Suggestions When Using 3M Application Tapes

- Do not apply brake pressure to the application tape feed roller. Brake pressure stretches the tape during lamination causing the application tape to shrink on the finished graphic.
- The application tape laminator should have at least one rubber squeeze roller at the nip site.
- The recommended nip pressure setting depends on the device used. In general, higher pressures and temperatures will provide higher adhesion of the application tape to the film and exposed liner. Excessive pressure can cause the application tape or the film's liner to curl.
- An edge guide and a feed table can be used to keep the graphic aligned with the application tape.
- After completing a job, the laminator may be left threaded, but remove the pressure from the squeeze rollers. Prolonged pressure flattens the rollers, which can cause lamination problems.
- A heated roller may be used up to a temperature of 200°F.

Shelf Life, Storage, Handling

An application tape helps graphics resist normal surface abrasion during storage, handling and application.

As tape ages or when stored at elevated temperatures, its adhesive becomes more aggressive. Unrolling the tape during mechanical application can cause the tape to stretch resulting in pop-off and curl of the graphic. If the graphic has been improperly stored, the tape can be difficult to remove from finished graphics making removal more difficult and resulting in edge lifting.

Unused Application Tape

- The shelf life is one year from the date of purchase.
- Store in a cool, dry place, suspended horizontally from the core.
- Avoid exposure to sunlight.

Graphics with Application Tape Applied

- After the application tape has been applied to the graphic, store in a cool, dry place and avoid exposure to sunlight.
- Most films: Store flat or wrapped onto cores with a minimum diameter of 6 inches (15 cm). Wrap so the side of the film with the application tape faces out.
- Film 680CR, IJ680CR, FN680CR, RG680CR: Finished graphics with exposed liner and application tape, must be shipped lying flat. This method will help prevent the graphics and prespacing tape from popping off the liner.
- Apply the finished graphic within one year from the date of its processing.

Important Note!

After applying application tape, avoid exposing the graphic to sunlight except during application. Sunlight, or UV light, can cause the tape to permanently bond to the film.

3M Related Literature

Before starting any job, be sure you have the most current Product and Instruction Bulletins.

The information in 3M Product and Instruction Bulletins is subject to change. Current Bulletins are available at 3Mgraphics.com. The following applicable Bulletins provide information and processes you need to properly make the graphics described in this Bulletin. Additional Bulletins may be needed as indicated in the 3M Related Literature section of other 3M components you use.

	Subject	Bulletin No.
Product Bulletins	Films, Overlaminates, Inks and Clears Please visit our web site or our Fax on Demand system to identify and obtain the additional Product and Instruction Bulletins you need for a successful application.	
Instruction Bulletins	Scoring and cutting	4.1
	Application, substrate selection, preparation and substrate-specific application techniques	5.1
	Application, special applications and vehicles	5.4
	Application, general procedures for indoor and outdoor dry applications	5.5
	A guide to understanding and applying graphics to common indoor and outdoor wall surfaces	5.37
Warranties	3M Graphics Center Warranty Brochure	

3M, Comply, Controltac, MCS, Scotchcal and Scotchlite are trademarks of 3M.

Bulletin Change Summary

Improved clarity in tables on pages 3 & 4. Please take special note of these changes:

- Table 1 is for unprinted films *with or without Comply adhesive, as well as overlaminates*.
- Table 2 is for any 3M solvent-based ink and the listed clears, and for film 3545C with any recommended solvent clear. Clear 2920DR is obsolete and replaced by 1920DR.
- Table 3 is for any 3M UV ink and the listed clears.
- Table 4 now includes changeable films IJ46 and IJ63.
- Table 6 is for films without Comply adhesive, with any 3M solvent-based ink and the listed clears.
- Table 7 is for any 3M UV ink and the listed clears.

Follow the recommended cutting sizes found in each film's Product Bulletin.

**Commercial Graphics Division**

3M India Ltd., Concorde Block,
UB City, 24, Vittal Mallya Road,
Bangalore, India.
Tel: +91-80-2223 1414 | 6659 5776
Fax: +91-80-2223 1450

Customer Contact Center :

1-800-425-3030 (Toll Free)

www.3m.com/in/graphics

Commercial Graphics Division

3M Center, Building 220-12E-04
PO Box 33220
St. Paul, MN 55144-3220 USA
General Info. 1-800-374-6772
Technical Info. 1-800-328-3908
Fax 1-651-736-4233

3M Canada

P.O. Box 5757
London, Ontario
Canada N6A 4T1
1-800-265-1840
Fax 519-452-6245

3M México, S.A. de C.V

Av. Santa Fe No. 55
Col. Santa Fe, Del. Alvaro Obregón
México, D.F. 01210
52-55-52-70-04-00
Fax 52-55-52-70-22-77

3M Puerto Rico, Inc.

Puerto Rico Industrial Park
350 Chardon Avenue, Suite 1100
San Juan PR 00918
787-620-3000
Fax 787-620-3018

©3M 2010. All rights reserved.