



Thread Milling

The MaxThread™ and the AccuThread 856® threadmill ranges are designed to deliver outstanding performance, long tool life and high precision, whether using our solid carbide or indexable insert threadmills.

CONTENTS

Thread Milling Range	Page 262
How to Identify Information	Page 264
MaxThread Thread Mills (BSPP/BSPT/BSW)	Page 265
MaxThread Thread Mills (NPT/NPTF)	Page 266
MaxThread Thread Mills (UN)	Page 267
MaxThread Thread Mills (Metric)	Page 268
MaxThread Thread Mills - Technical Section	Page 269
AccuThread Thread Mills (BSPP/BSPT/BSW)	Page 270
AccuThread Thread Mills (NPT/NPTF/AccuPort)	Page 271
AccuThread Thread Mills (UN)	Page 272
AccuThread Thread Mills (Metric & made to order)	Page 273
AccuThread Bolt in Style Inserts (UN)	Page 274
AccuThread Bolt in Style Inserts (UNJ)	Page 275
AccuThread Bolt in Style Inserts (Metric/BSPP)	Page 276
AccuThread Bolt in Style Holder (UN/ISO/BSPP)	Page 276
AccuThread Bolt in Style Inserts (BSPT/NPT/NPTF)	Page 277
AccuThread Bolt in Style Holder (NPT/NPTF/BSPT)	Page 277
AccuThread Pin Style Inserts (NPT/NPTF/BSPP/BSPT/API)	Page 278
AccuThread Pin Style Inserts (UN)	Page 279
AccuThread Pin Style Inserts (UNJ)	Page 280
AccuThread Pin Style Inserts (Metric/ACME)	Page 281
AccuThread Pin Style Holders	Page 282
AccuThread Technical Section	Page 283
Guaranteed Application Request Form	Page 301



Features and Benefits

- Complete programme available of both solid carbide and indexable thread mills
- All tools can produce left or right hand threads
- Full profiles present on all inserts and solid carbide thread mills
- High technology manufacturing ensures consistent thread forms



Thread Milling

High Performance Threading Solutions

AMEC's thread milling programme has developed into a comprehensive range of high precision tooling offering outstanding productivity with exceptional levels of tool life and thread accuracy. The thread mill range covers both solid carbide and indexable replaceable insert tools with an extensive range of threads forms.

Our thread milling programme has been specifically designed to provide customers with a wide choice. This is achieved by offering two thread mill ranges within our product line up – the low cost, general purpose MaxThread™ thread mill range and the high performance, high productivity AccuThread 856® range.

Both product ranges are designed for manufacturing and production environments and offer excellent performance and thread accuracy, allowing AMEC® to offer the best product for the job, to help give our customers the cutting edge.

Also available is AMEC's 'Special Products', solutions that provide engineers, designers and production managers with the opportunity of creating application specific tooling that can achieve levels of efficiency and performance beyond standard threading solutions.

Solid Carbide

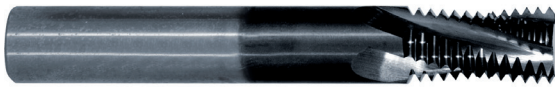

MaxThread™ Thread Mills

The MaxThread™ threadmill range is manufactured from solid carbide with ground helical flutes and a TiAlN coating as standard. These product have been designed for the low volume / low cost production environment, providing excellent performance at a competitive price.

A helical flute design has been maintained across the MaxThread™ range to allow for maximum production benefits and to negate the need for straight flute thread mills. A comprehensive range of thread forms and technical information further supports the programme.

Features and Benefits

- Helical flute which offers increased strength and rigidity when cutting forces are applied
- TiAlN coated for increased tool life over uncoated tools
- Extensive range of thread forms
- High quality for consistent predictable production

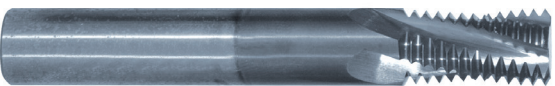

AccuThread 856®

The AccuThread 856® is AMEC's premium thread milling product range, manufactured from micro grain carbide and coated in AMEC's AM210® premium coating. This product is designed for the demanding environment of high production thread milling, providing extraordinary tool life and exceptionally high quality thread forms. The AccuThread range is available in a wide selection of thread standards and forms part of our specials programme allowing you to tailor design threadmills to your specific requirements.

Features and Benefits

- AMEC's proprietary AM210® coating has a 25-50% increase in tool life over competitor product
- Standard cutting lengths allow for multiple applications without the need for special thread mills
- Helical flute which offers increased strength and rigidity when cutting forces are applied
- CNC G code programmes available



Indexable Thread Milling

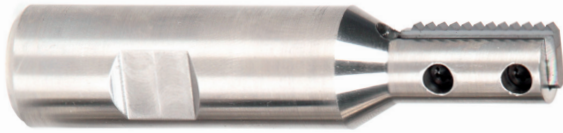

AccuThread 856® - Bolt in style

The AccuThread 856® indexable bolt in style is our general purpose system available in two insert lengths with an extensive range of thread forms. The tool holders are manufactured from engineered dampened stainless steel providing excellent rigidity when in contact with the work pieces, helping to provide quality thread forms.

Features and Benefits

- Thread mill holders are manufactured from stainless steel that is engineered to dampen vibration during operation
- Extensive range of thread forms with two thread lengths
- Can produce left or right handed threads



AccuThread 856® - Pin style

The AccuThread 856® indexable pin style is designed to allow for a deeper working thread and higher rigidity, enabling high productivity, extended tool life and excellent performance when producing threads. The tool holders are manufactured from dampened stainless steel, which provides outstanding rigidity when in contact with the work piece, helping ensure high quality thread forms are produced. Pin style tool holders incorporate through coolant as standard.

Features and Benefits

- Patented pin style locking system ensures unsurpassed repeatability
- Thread mill holders are manufactured from stainless steel that is engineered to dampen vibration during operation
- Extensive range of thread forms with two thread lengths

AccuThread 856® - Indexable inserts



Bolt-in Style



Pin Style

Features and Benefits

- Full profiles present on all inserts allows 100% thread form against 65-75% for tapping
- AMEC's proprietary AM210® coating has a 25-50% increase in tool life over competitor product
- AMEC's premium carbide allows for extended tool life whilst providing high quality thread forms



How to Identify Information

T-A & GENZ T-A
GENSYS
APX
Revolution & Core Drill
ASC 320 Solid Carbide
AccuPort 432
Criterion
Thread Milling
Special Tooling

MaxThread™ Solid Carbide Threadmills

MAX	A	0250	BSW	20
MaxThread	Coating	Min. Thread Dia.	Thread Forms	Thread Pitch
	A – TiAIN	Imperial – 0250 = ¼" Number Drill – 0008 - #8 Metric – 0450 = M 4.5	BSW BSPP BSPT NPT NPTF	UN – 20 Metric – 1.0
Metric and UN are shown with thread diameter and pitch only				

AccuThread 856® Solid Carbide Threadmills

TM	U	K	0250	-	20	M	
AccuThread	Thread Class	Coating	Min. Thread Dia.		Thread Pitch / TPI / Thread Form	Size	Shank Designation
TM - Cylindrical Shank TW - Shank with Weldon flat	U - UN, UNF N - NPT, NPTF M - Metric A - Accuport® Specific B - BSP, BSPT, BSW	K - AM210®	Imperial - 0250 = ¼" Number Drill - 0008 - #8 Metric - 0450 = M 4.5		UN - 20 = 20 TPI Metric - 100 = 1.0 pitch Thread Forms - BSPP, BSPT, BSW NPT, NPTF	Blank - Standard XL - Extra Length	M - Metric

AccuThread 856® Indexable Threadmill Holders

THT	-	0400	-	1F	075	M
Holder Style		Cutter Dia.		# of Flutes	Length of Insert	Shank Designation
THT – Tapered Head THN – Straight Head (Neutral) THP – Straight Head (Positive) TSN – Shell Mill		400 - .400"(10.2mm)		1F – 1 Flute 2F – 2 Flutes 3F – 3 Flutes 5F – 5 Flutes 7F – 7 Flutes 8F – 8 Flutes	075 – ¾" 100 – 1.00" 150 – 1.50"	M - Metric

THT and THN Holders utilise bolt-in style inserts
THP and TSN Holders utilise pin style inserts

AccuThread 856® Indexable Threadmill Inserts

TP	075	K	-	UN	32	I
Insert Style	Insert Length	Coating		Thread Class	Thread Pitch	Thread Style
TP – Positive – Bolt In TN – Neutral – Pin & Screw	075 – ¾" 100 – 1.00" 150 – 1.50"	K – AM210®		UN, UNJ NPT, NPTF BSP, BSPT M - Metric F – Full ACME AP – API Round	UN – 20 Metric – 1.0	I - Internal E - External

MaxThread™ Threadmills

Solid Carbide Threadmills BSPP/BSPT & BSW
TiAlN coated

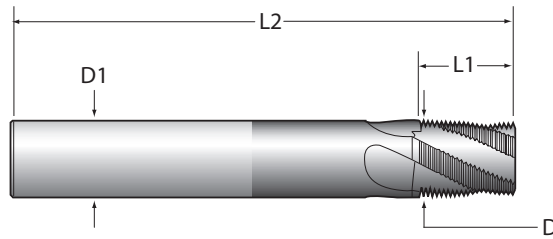
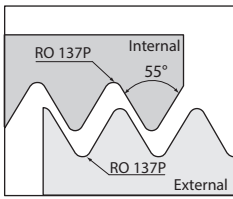

Solid Carbide Threadmills BSPP

Part Number	BSP Size	Thread per Inch	Flutes	Max Cutter Dia (D)	Shank Dia (D1)	Length of Cut (L1)	OAL (L2)	Stk.
				mm	mm	mm	mm	
MAXA0063BSPP28	1/16" and 1/8" BSPP	28	3	5.97	6.00	14.53	51.00	●
MAXA0250BSPP19	1/4" and 3/8" BSPP	19	4	9.91	10.00	18.72	73.00	●
MAXAF0375BSPP19	3/8" BSPP	19	4	11.94	12.00	29.00	84.00	●
MAXA0500BSPP14	1/2" and 3/4" BSPP	14	4	11.94	12.00	29.03	84.00	●
MAXAF0500BSPP14	1/2"-5/8"-3/4"-7/8"	14	5	15.75	16.00	34.47	93.00	●
MAXAF1000BSPP11	1"	11	5	15.75	16.00	34.67	93.00	●
MAXA1000BSPP11	1" to 2" BSPP	11	4	15.75	16.00	34.67	93.00	●

Note - Shank with Weldon flat available, price and delivery on request

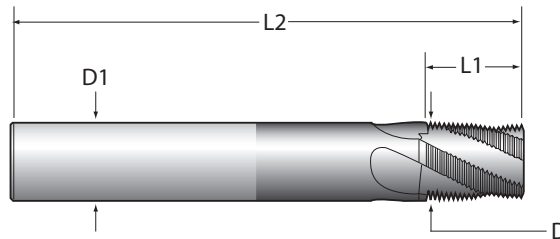
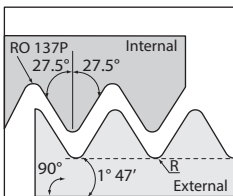

Solid Carbide Threadmills BSPT

Part Number	BSPT Size	Thread per Inch	Flutes	Max Cutter Dia (D)	Shank Dia (D1)	Length of Cut (L1)	OAL (L2)	Stk.
				mm	mm	mm	mm	
MAXA0063BSPT28	1/16" and 1/8" BSPT	28	3	5.97	6.00	9.98	51.00	●
MAXA0250BSPT19	1/4" and 3/8" BSPT	19	4	9.91	10.00	14.73	73.00	●
MAXA0500BSPT14	1/2" and 3/4" BSPT	14	4	11.94	12.00	20.00	84.00	●
MAXA1000BSPT11	1" to 2" BSPT	11	4	15.75	16.00	32.31	93.00	●

Note - Shank with Weldon flat available, price and delivery on request

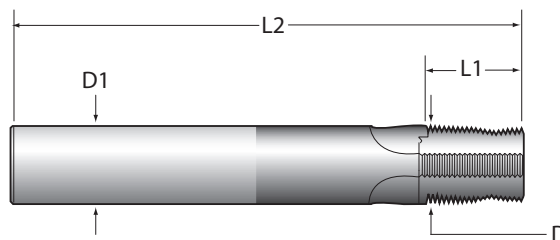
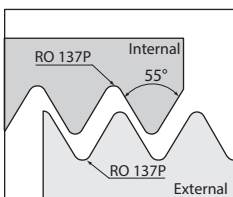

Solid Carbide Threadmills BSW

Part Number	Min. Thread Size	Thread per Inch	Flutes	Max Cutter Dia (D)	Shank Dia (D1)	Length of Cut (L1)	OAL (L2)	Stk.
				mm	mm	mm	mm	
MAXA0250BSW20	1/4"	20	3	4.50	6.00	10.21	58	●
MAXA0312BSW18	5/16"	18	3	5.00	6.00	11.30	58	●
MAXA0375BSW16	3/8"	16	5	7.00	8.00	14.32	64	●
MAXA0437BSW14	7/16"	14	5	7.90	8.00	18.16	64	●
MAXA0500BSW12	1/2" - 9/16"	12	5	9.00	10.00	19.10	73	●
MAXA0625BSW11	5/8"	11	5	11.90	12.00	23.16	84	●
MAXA0750BSW10	3/4"	10	5	11.90	12.00	27.99	84	●
MAXA0875BSW9	7/8"	9	6	15.90	16.00	28.32	93	●
MAXA1000BSW8	1"	8	6	15.90	16.00	34.98	93	●

Note - Shank with Weldon flat available, price and delivery on request



MaxThread™ Threadmills

Solid Carbide Threadmills NPT/NPTF
TiAlN coated

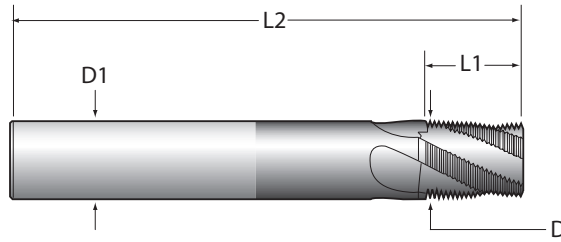
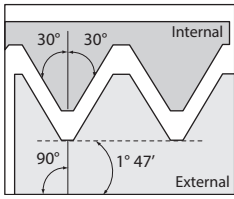

Solid Carbide Threadmills NPT

Part Number	NPT Size	Thread per Inch	Flutes	Max Cutter Dia (D)	Shank Dia (D1)	Length of Cut (L1)	OAL (L2)	Stk.
				mm	mm	mm	mm	
MAXA0063NPT27	1/16" and 1/8" NPT	27	3	5.95	6.00	11.30	58.00	●
MAXA0250NPT18	1/4" and 3/8" NPT	18	4	7.75	8.00	15.70	64.00	●
MAXA0500NPT14	1/2" and 3/4" NPT	14	4	11.95	12.00	23.70	84.00	●
MAXA1000NPT115	1" to 2" NPT	11.5	4	15.75	16.00	28.75	93.00	●
MAXA2500NPT8	2-1/2" to 6" NPT	8	5	19.75	20.00	38.10	115.00	●

Note - Shank with Weldon flat available, price and delivery on request

Solid Carbide Threadmills NPTF

Part Number	NPTF Size	Thread per Inch	Flutes	Max Cutter Dia (D)	Shank Dia (D1)	Length of Cut (L1)	OAL (L2)	Stk.
				mm	mm	mm	mm	
MAXA0063NPTF27	1/16" and 1/8" NPTF	27	3	5.95	6.00	11.30	58.00	○
MAXA0250NPTF18	1/4" and 3/8" NPTF	18	4	7.75	8.00	15.70	64.00	○
MAXA0500NPTF14	1/2" and 3/4" NPTF	14	4	11.95	12.00	23.70	84.00	○
MAXA1000NPTF115	1" to 2" NPTF	11.5	4	15.75	16.00	28.75	93.00	○
MAXA2500NPTF8	2-1/2" to 6" NPTF	8	5	19.75	20.00	38.10	115.00	○

Note - Shank with Weldon flat available, price and delivery on request

Note: Solid Carbide Threadmills are sold in packs of 1

Stk. - Stock Availability

- Stocked.
 - Stocked in limited quantities
 - ◆ Non-Stocked Standard – 25 working days delivery
- All other coatings are non-stocked standards – 25 working day delivery applies

T-A & GENZ T-A
GENSSYS
APX
Revolution & Core Drill
ASC 320 Solid Carbide
AccuPort 432
Criterion
Thread Milling
Special Tooling

MaxThread™ Threadmills

Solid Carbide Threadmills UN
TiAlN coated

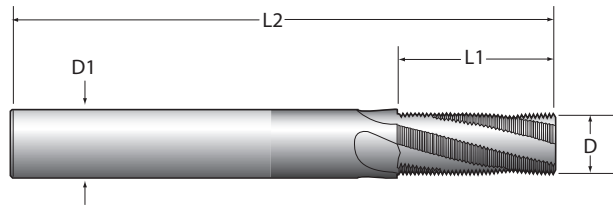
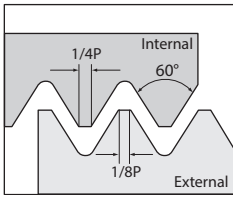

Solid Carbide Threadmills UN

Part Number	Min. Thread Size	Thread per Inch	Flutes	Max Cutter Dia (D)	Shank Dia (D1)	Length of Cut (L1)	OAL (L2)	Stk.
				mm	mm	mm	mm	
MAXA0002x64*	#2	64	3*	1.65	3.00	3.20	39.00	●
MAXA0002x56*	#2	56	3*	1.65	3.00	3.20	39.00	●
MAXA0003x48*	#3	48	3*	1.80	3.00	3.75	39.00	●
MAXA0004x40*	#4	40	3*	2.20	3.00	4.45	39.00	●
MAXA0005x44	#5	44	3	2.40	3.00	4.65	39.00	●
MAXA0006x32	#6	32	3	2.50	3.00	5.55	39.00	●
MAXA0008x36	#8	36	3	3.00	4.00	6.35	51.00	●
MAXA0008x32	#8	32	3	3.20	4.00	6.35	51.00	●
MAXA0010x32	#10	32	3	3.80	4.00	7.95	51.00	●
MAXA0010x28	#10	28	3	3.80	4.00	8.20	51.00	●
MAXA0010x24	#10	24	3	3.70	4.00	8.50	51.00	●
MAXA0250x28	1/4"	28	3	4.75	6.00	12.70	58.00	●
MAXA0250x20	1/4"	20	3	4.75	6.00	12.70	58.00	●
MAXA0313x24	5/16"	24	3	5.95	6.00	16.00	58.00	●
MAXA0313x18	5/16"	18	3	5.95	6.00	17.00	58.00	●
MAXA0375x24	3/8"	24	4	7.25	8.00	19.00	64.00	●
MAXA0375x16	3/8"	16	4	7.25	8.00	19.00	64.00	●
MAXA0438x28	7/16"	28	4	7.90	8.00	19.95	64.00	●
MAXA0438x20	7/16"	20	4	8.75	10.00	22.85	73.00	●
MAXA0438x14	7/16"	14	4	7.75	8.00	20.00	64.00	●
MAXA0500x13	1/2"	13	4	9.40	10.00	23.50	73.00	●
MAXA0563x18	9/16"	18	4	9.90	10.00	22.65	73.00	●
MAXA0563x12	9/16"	12	4	9.90	10.00	22.65	73.00	●
MAXA0625x11	5/8"	11	4	11.95	12.00	32.40	84.00	●
MAXA0750x16	3/4"	16	4	11.95	12.00	31.75	84.00	●
MAXA0750x12	3/4"	12	4	11.95	12.00	31.75	84.00	●
MAXA0750x10	3/4"	10	4	11.95	12.00	33.00	84.00	●
MAXA0875x14	7/8"	14	4	11.95	12.00	32.70	84.00	●
MAXAF0875x14	7/8"	14	5	15.75	16.00	34.47	93.00	●
MAXA0875x9	7/8"	9	4	15.75	16.00	36.75	93.00	●
MAXA1000x8	1"	8	4	15.75	16.00	35.00	93.00	●
MAXAF1000x12	1"-1 1/16"-1 1/8"-1 1/4"	12	5	15.75	16.00	33.87	93.00	●
MAXA1125x7	1 1/8"	7	5	19.90	20.00	36.30	105.00	●
MAXA1375x6	1 3/8"	6	5	19.90	20.00	38.10	105.00	●

Note - Shank with Weldon flat available over 6mm shank diameter, price and delivery on request

* Items marked with an asterisk are straight fluted

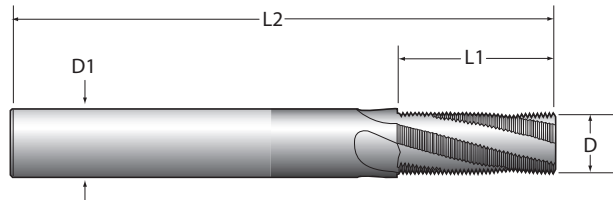
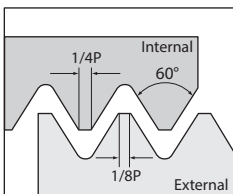

Solid Carbide Threadmills UN Extra Length

Part Number	Min. Thread Size	Thread per Inch	Flutes	Max Cutter Dia (D)	Shank Dia (D1)	Length of Cut (L1)	OAL (L2)	Stk.
				mm	mm	mm	mm	
MAXA0625x11XL	5/8"	11	4	11.95	12.00	37.00	100.00	○
MAXA0750x10XL	3/4"	10	4	11.95	12.00	40.70	100.00	○
MAXA0875x9XL	7/8"	9	4	15.75	16.00	45.20	100.00	○
MAXA1000x8XL	1"	8	6	19.90	20.00	50.80	115.00	○

Note - Shank with Weldon flat available, price and delivery on request



MaxThread™ Threadmills

Solid Carbide Threadmills Metric ISO
TiAlN coated

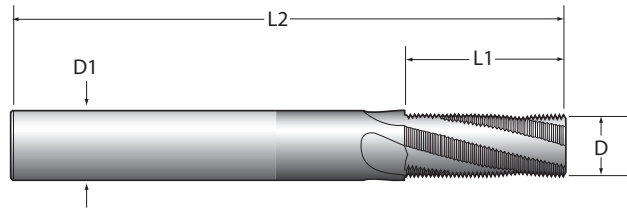
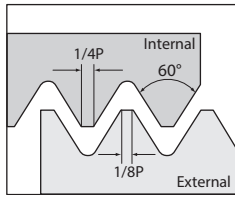

Solid Carbide Threadmills Metric

Part Number	Thread Size	Pitch	Flutes	Max Cutter Dia (D)	Shank Dia (D1)	Length of Cut (L1)	OAL (L2)	Stk.
				mm	mm	mm	mm	
MAXA0200x040*	M2	0.40	3*	1.50	3.00	3.20	39.00	●
MAXA0250x045*	M2.5	0.45	3*	1.50	3.00	3.60	39.00	●
MAXA0300x050*	M3	0.50	3*	2.15	3.00	4.50	39.00	●
MAXA0400x070	M4	0.70	3	2.90	3.00	8.00	39.00	●
MAXA0450x075	M4.5	0.75	3	3.00	4.00	6.75	51.00	●
MAXA0500x080	M5	0.80	3	3.60	4.00	8.00	51.00	●
MAXA0600x100	M6	1.00	3	4.60	6.00	12.00	51.00	●
MAXA0600x075	M6	0.75	3	4.60	6.00	12.00	51.00	●
MAXA0600x050	M6	0.50	3	4.60	6.00	12.00	58.00	●
MAXA0800x125	M8	1.25	3	5.90	6.00	16.25	51.00	●
MAXA1000x150	M10	1.50	4	7.40	8.00	19.50	64.00	●
MAXA1000x075	M10	0.75	4	7.95	8.00	15.00	64.00	●
MAXA1000x050	M10	0.50	4	7.95	8.00	15.00	64.00	●
MAXA1200x175	M12	1.75	4	9.40	10.00	22.71	73.00	●
MAXA1200x100	M12	1.00	4	9.40	10.00	20.00	73.00	●
MAXA1400x150	M14	1.50	4	10.90	12.00	27.00	84.00	●
MAXA1400x200	M14	2.00	4	10.90	12.00	28.00	84.00	●
MAXA1800x150	M18	1.50	4	11.90	12.00	31.50	84.00	●
MAXA2000x250	M20	2.50	4	11.90	12.00	30.00	84.00	●
MAXA2000x200	M20	2.00	4	11.95	12.00	30.00	84.00	●
MAXAF2000x150	M20-M22-M24	1.50	5	15.75	16.00	36.00	93.00	●
MAXA2400x300	M24	3.00	4	15.90	16.00	36.00	93.00	●
MAXA3000x350	M30	3.50	4	15.75	16.00	38.50	100.00	●
MAXA3600x400	M36	4.00	5	19.90	20.00	40.00	105.00	●

Note - Shank with Weldon flat available over 6mm shank diameter, price and delivery on request

* Items marked with an asterisk are straight fluted

Stk. - Stock Availability

- Stocked.
 - Stocked in limited quantities
 - ◆ Non-Stocked Standard – 25 working days delivery
- All other coatings are non-stocked standards – 25 working day delivery applies

Technical Section - MaxThread™ Threadmills



Recommended Cutting Data
Solid Carbide Threadmills

Material	Material Hardness (BHN)	Material Machinability	TiAlN M/min	Cutter (mm)							
				Recommended Feed (mm/tooth)							
				3	5	6	8	10	12	16	19
Free Machining Steel	100-150	Easy	167	0.010	0.013	0.018	0.023	0.025	0.038	0.051	0.064
	150-200	Easy	130	0.010	0.013	0.018	0.023	0.025	0.038	0.051	0.064
	200-250	Easy	93	0.010	0.013	0.018	0.023	0.025	0.038	0.051	0.064
Low Carbon Steel	85-125	Average	167	0.010	0.013	0.018	0.023	0.025	0.038	0.051	0.064
	125-175	Average	130	0.010	0.013	0.018	0.023	0.025	0.038	0.051	0.064
	175-225	Average	112	0.010	0.013	0.018	0.023	0.025	0.038	0.051	0.064
	225-275	Average	93	0.010	0.013	0.018	0.023	0.025	0.038	0.051	0.064
Medium Carbon Steel	125-175	Average	137	0.010	0.013	0.015	0.020	0.025	0.033	0.046	0.051
	175-225	Average	120	0.010	0.013	0.015	0.020	0.025	0.033	0.046	0.051
	225-275	Average	107	0.010	0.013	0.015	0.020	0.025	0.033	0.046	0.051
	275-325	Average	95	0.010	0.013	0.015	0.020	0.025	0.033	0.046	0.051
Alloy Steel	125-175	Average	107	0.010	0.013	0.015	0.020	0.025	0.033	0.046	0.051
	175-225	Average	93	0.010	0.013	0.015	0.020	0.025	0.033	0.046	0.051
	225-275	Average	84	0.010	0.013	0.015	0.020	0.025	0.033	0.046	0.051
	275-325	Difficult	75	0.010	0.013	0.015	0.020	0.025	0.033	0.046	0.051
	325-375	Difficult	70	0.010	0.013	0.015	0.020	0.025	0.033	0.046	0.051
High Strength Alloy Steel	225-300	Average	89	0.010	0.013	0.015	0.020	0.025	0.033	0.046	0.051
	300-350	Difficult	80	0.010	0.013	0.015	0.020	0.025	0.033	0.046	0.051
	350-400	Difficult	70	0.010	0.013	0.015	0.020	0.025	0.033	0.046	0.051
Structural Steel	100-150	Average	143	0.010	0.013	0.018	0.023	0.025	0.038	0.051	0.064
	150-250	Average	119	0.010	0.013	0.018	0.023	0.025	0.038	0.051	0.064
	250-350	Difficult	107	0.010	0.013	0.018	0.023	0.025	0.038	0.051	0.064
Tool Steel	150-200	Difficult	107	0.010	0.013	0.018	0.023	0.025	0.038	0.051	0.064
	200-250	Difficult	93	0.010	0.013	0.018	0.023	0.025	0.038	0.051	0.064
High Temp Alloy	140-220	Difficult	31	0.008	0.010	0.015	0.020	0.023	0.025	0.030	0.038
	220-310	Difficult	21	0.008	0.010	0.015	0.020	0.023	0.025	0.030	0.038
Stainless Steel	135-185	Average	101	0.010	0.013	0.015	0.020	0.023	0.025	0.038	0.051
	185-275	Difficult	96	0.010	0.013	0.015	0.020	0.023	0.025	0.038	0.051
Stainless Steel PH	185-275	Average	58	0.010	0.013	0.015	0.020	0.023	0.025	0.038	0.051
	275-325	Difficult	29	0.010	0.013	0.015	0.020	0.023	0.025	0.038	0.051
Cast Iron	120-150	Easy	152	0.010	0.013	0.018	0.023	0.025	0.038	0.051	0.064
	150-200	Easy	142	0.010	0.013	0.018	0.023	0.025	0.038	0.051	0.064
	200-220	Easy	130	0.010	0.013	0.018	0.023	0.025	0.038	0.051	0.064
	220-260	Average	113	0.010	0.013	0.018	0.023	0.025	0.038	0.051	0.064
	260-320	Average	108	0.010	0.013	0.018	0.023	0.025	0.038	0.051	0.064
Aluminium, Wrought	30	Easy	335	0.013	0.015	0.023	0.025	0.038	0.051	0.064	0.076
	180	Easy	305	0.013	0.015	0.023	0.025	0.038	0.051	0.064	0.076
Cast Aluminium*	120	Easy	191	0.013	0.015	0.023	0.025	0.038	0.051	0.064	0.076
Brass	30-125	Easy	295	0.013	0.015	0.023	0.025	0.038	0.051	0.064	0.076

Formulas: Linear Feed Rate = RPM x mm/tooth x No. of Teeth M/min = (RPM x 3.142 x Dia)/1000. RPM = (M/min x 1000) / (Dia x 3.142)
Adjusted Feed Rate (AFR) for Internal Thread Milling = (Thread Major Dia – Cutter Dia) / major Dia x Linear Feed Rate

The above formula on an internal thread program adjusts the linear feed rate to be applied to the O.D. instead of the centre of the cutting tool. If the feed rate is not adjusted, the excessive feed rate will cause the thread mill cutting edges to fail.

Example of an Internal Thread Feed Rate Calculation: Cast Iron 125 BHN with a ½ - 13 thread form.

Step 1	Step 2	Step 3
RPM=(m/min x 1000)/(Dia x 3.142)	Linear Feed Rate = RPM x mm/tooth x No of teeth	AFR for Internal Thread Milling = (Major Dia-Cutter Dia) / Major Dia) x Linear Feed Rate
RPM=(152 x 1000)/(8.89 x 3.142)	Linear Feed Rate = 5442 x 0.038 x 4	AFR for Internal Thread Milling = (12.7 – 8.89) / 12.7) x 827.18
RPM=5442	Linear Feed Rate = 827.18 mm/min	AFR for Internal Thread Milling = 248.15mm/min

Note: Reduce feed and speed by 30% for NPT and NPTF Thread Forms due to tapered cutting action
* Uncoated thread mills are recommended for cast aluminium applications (price and availability upon request)
Refer to recommended pass chart on page 286 when referencing material machinability



AccuThread 856[®]

Solid Carbide Threadmills BSPP/BSPT/BSW
AM210[®] coated

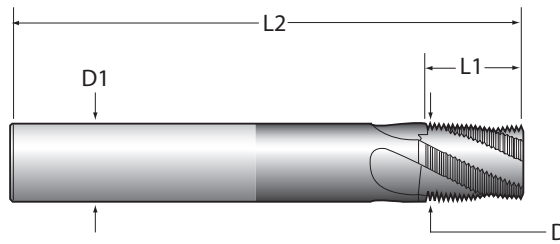
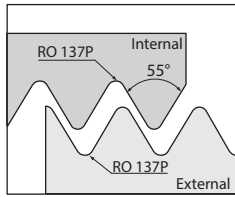

Solid Carbide Threadmills BSPP

Part Number	BSP Size	Thread per Inch	Flutes	Max Cutter Dia (D)	Shank Dia (D1)	Length of Cut (L1)	OAL (L2)	Stk.
				mm	mm	mm	mm	
TMBK0063-BSPPM	1/16" and 1/8" BSP	28	3	5.97	6.00	14.53	51.00	●
TMBK0250-BSPPM	1/4" and 3/8" BSP	19	4	9.91	10.00	18.72	73.00	●
TMBKF0375-BSPPM	3/8"	19	4	11.94	12.00	29.00	84.00	●
TMBK0500-BSPPM	1/2" and 3/4" BSP	14	4	11.94	12.00	29.03	84.00	●
TMBKF0500-BSPPM	1/2"-5/8"-3/4"-7/8"	14	5	15.75	16.00	34.47	93.00	●
TMBKF1000-BSPPM	1"	11	5	15.75	16.00	34.67	93.00	●
TMBK1000-BSPPM	1" to 2" BSP	11	4	15.75	16.00	34.67	93.00	●

Note - Shank with Weldon flat available, price and delivery on request

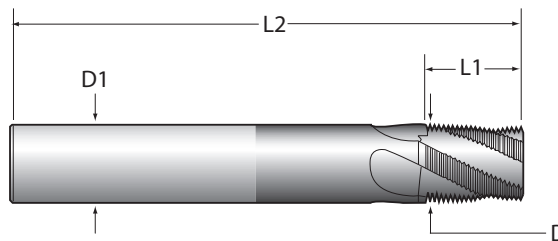
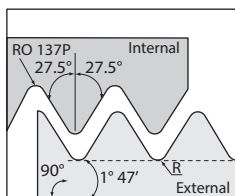

Solid Carbide Threadmills BSPT

Part Number	BSPT Size	Thread per Inch	Flutes	Max Cutter Dia (D)	Shank Dia (D1)	Length of Cut (L1)	OAL (L2)	Stk.
				mm	mm	mm	mm	
TMBK0063-BSPTM	1/16" and 1/8" BSPT	28	3	5.97	6.00	9.98	51.00	●
TMBK0250-BSPTM	1/4" and 3/8" BSPT	19	4	9.91	10.00	14.73	73.00	●
TMBK0500-BSPTM	1/2" and 3/4" BSPT	14	4	11.94	12.00	20.00	84.00	●
TMBK1000-BSPTM	1" to 2" BSPT	11	4	15.75	16.00	32.31	93.00	●

Note - Shank with Weldon flat available, price and delivery on request

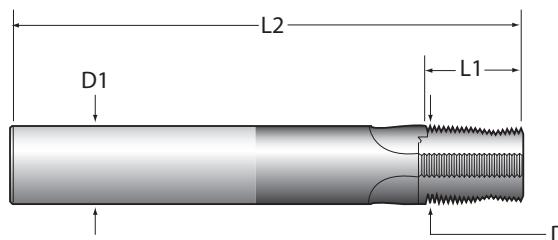
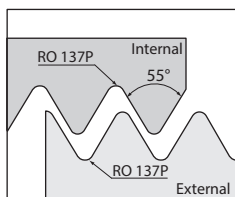

Solid Carbide Threadmills BSW

Part Number	Min. Thread Size	Thread per Inch	Flutes	Max Cutter Dia (D)	Shank Dia (D1)	Length of Cut (L1)	OAL (L2)	Stk.
				mm	mm	mm	mm	
TMBK0250-BSWM	1/4"	20	3	4.50	6.00	10.21	58	●
TMBK0312-BSWM	5/16"	18	3	5.00	6.00	11.30	58	●
TMBK0375-BSWM	3/8"	16	5	7.00	8.00	14.32	64	●
TMBK0437-BSWM	7/16"	14	5	7.90	8.00	18.16	64	●
TMBK0500-BSWM	1/2" - 9/16"	12	5	9.00	10.00	19.10	73	●
TMBK0625-BSWM	5/8"	11	5	11.90	12.00	23.16	84	●
TMBK0750-BSWM	3/4"	10	5	11.90	12.00	27.99	84	●
TMBK0875-BSWM	7/8"	9	6	15.90	16.00	28.32	93	●
TMBK1000-BSWM	1"	8	6	15.90	16.00	34.98	93	●

Note - Shank with Weldon flat available, price and delivery on request



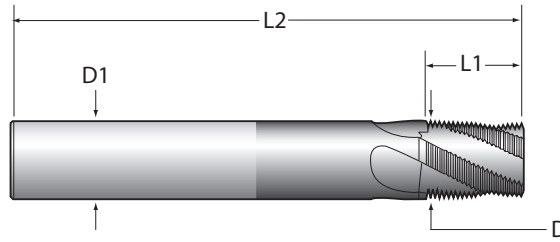
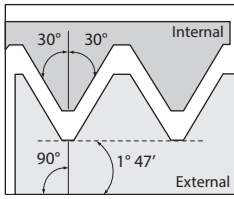

Solid Carbide Threadmills NPT

Part Number	NPT Size	Thread per Inch	Flutes	Max Cutter Dia (D)	Shank Dia (D1)	Length of Cut (L1)	OAL (L2)	Stk.
				mm	mm	mm	mm	
TMNK0063-NPTM	1/16" and 1/8" NPT	27	3	5.95	6.00	11.30	58.00	●
TMNK0250-NPTM	1/4" and 3/8" NPT	18	4	7.75	8.00	15.70	64.00	●
TMNK0500-NPTM	1/2" and 3/4" NPT	14	4	11.95	12.00	23.70	84.00	●
TMNK1000-NPTM	1" to 2" NPT	11.5	4	15.75	16.00	28.75	93.00	●
TMNK2500-NPTM	2-1/2" to 6" NPT	8	4	19.75	20.00	38.10	115.00	●

Note - Shank with Weldon flat available, price and delivery on request

Solid Carbide Threadmills NPTF

Part Number	NPTF Size	Thread per Inch	Flutes	Max Cutter Dia (D)	Shank Dia (D1)	Length of Cut (L1)	OAL (L2)	Stk.
				mm	mm	mm	mm	
TMNK0063-NPTFM	1/16" and 1/8" NPTF	27	3	5.95	6.00	11.30	58.00	○
TMNK0250-NPTFM	1/4" and 3/8" NPTF	18	4	7.75	8.00	15.70	64.00	○
TMNK0500-NPTFM	1/2" and 3/4" NPTF	14	4	11.95	12.00	23.70	84.00	○
TMNK1000-NPTFM	1" to 2" NPTF	11.5	4	15.75	16.00	28.75	93.00	○
TMNK2500-NPTFM	2-1/2" to 6" NPTF	8	4	19.75	20.00	38.10	115.00	○

Note - Shank with Weldon flat available, price and delivery on request

Note: Solid Carbide Threadmills are sold in packs of 1

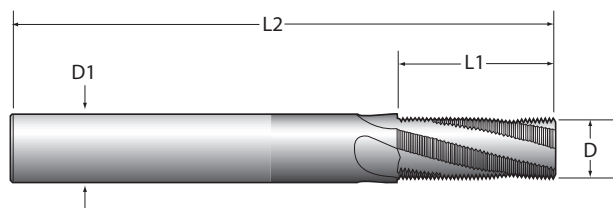
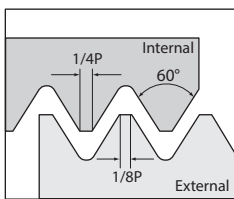

Solid Carbide Threadmills AccuPort 432[®] Specific UN

Part Number	Min. Thread Size	Thread per Inch	Flutes	Max Cutter Dia (D)	Shank Dia (D1)	Length of Cut (L1)	OAL (L2)	Stk.
				mm	mm	mm	mm	
TMAK0438-20M	-4 to -5	20	4	8.51	10.00	15.24	73.00	●
TMAK0563-18M	-6	18	4	9.40	10.00	16.92	73.00	●
TMAK0750-16M	-8	16	4	11.94	12.00	19.05	84.00	●
TMAK0875-14M	-10	14	4	11.94	12.00	21.77	84.00	●
TMAK1063-12M	-12 to -32	12	4	11.94	12.00	23.29	84.00	●

Note - Shank with Weldon flat available, price and delivery on request

Stk. - Stock Availability

- Stocked.
- Stocked in limited quantities
- ◆ Non-Stocked Standard – 25 working days delivery
- All other coatings are non-stocked standards – 25 working day delivery applies



AccuThread 856[®]

Solid Carbide Threadmills UN
AM210[®] coated

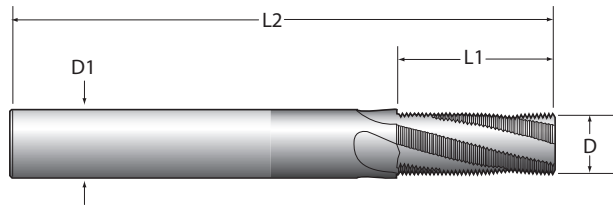
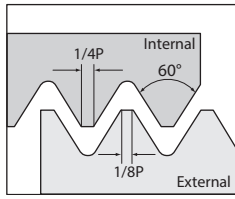

Solid Carbide Threadmills UN

Part Number	Min. Thread Size	Thread per Inch	Flutes	Max Cutter Dia (D)	Shank Dia (D1)	Length of Cut (L1)	OAL (L2)	Stk.
				mm	mm	mm	mm	
TMUK0002-64M	#2	64	3*	1.65	3.00	3.20	39.00	●
TMUK0002-56M	#2	56	3*	1.65	3.00	3.20	39.00	●
TMUK0003-48M	#3	48	3*	1.80	3.00	3.75	39.00	●
TMUK0004-40M	#4	40	3*	2.20	3.00	4.45	39.00	●
TMUK0005-44M	#5	44	3	2.40	3.00	4.65	39.00	●
TMUK0006-32M	#6	32	3	2.50	3.00	5.55	39.00	●
TMUK0008-36M	#8	36	3	3.00	4.00	6.35	51.00	●
TMUK0008-32M	#8	32	3	3.20	4.00	6.35	51.00	●
TMUK0010-32M	#10	32	3	3.80	4.00	7.95	51.00	●
TMUK0010-28M	#10	28	3	3.80	4.00	8.20	51.00	●
TMUK0010-24M	#10	24	3	3.70	4.00	8.50	51.00	●
TMUK0250-28M	1/4"	28	3	4.75	6.00	12.70	58.00	●
TMUK0250-20M	1/4"	20	3	4.75	6.00	12.70	58.00	●
TMUK0313-24M	5/16"	24	3	5.95	6.00	16.00	58.00	●
TMUK0313-18M	5/16"	18	3	5.95	6.00	17.00	58.00	●
TMUK0375-24M	3/8"	24	4	7.25	8.00	19.00	64.00	●
TMUK0375-16M	3/8"	16	4	7.25	8.00	19.00	64.00	●
TMUK0438-28M	7/16"	28	4	7.90	8.00	19.95	64.00	●
TMUK0438-20M	7/16"	20	4	8.75	10.00	22.85	73.00	●
TMUK0438-14M	7/16"	14	4	7.75	8.00	20.00	64.00	●
TMUK0500-13M	1/2"	13	4	9.40	10.00	23.50	73.00	●
TMUK0563-18M	9/16"	18	4	9.90	10.00	22.65	73.00	●
TMUK0563-12M	9/16"	12	4	9.90	10.00	22.65	73.00	●
TMUK0625-11M	5/8"	11	4	11.95	12.00	32.40	84.00	●
TMUK0750-16M	3/4"	16	4	11.95	12.00	31.75	84.00	●
TMUK0750-12M	3/4"	12	4	11.95	12.00	31.75	84.00	●
TMUK0750-10M	3/4"	10	4	11.95	12.00	33.00	84.00	●
TMUK0875-14M	7/8"	14	4	11.95	12.00	32.70	84.00	●
TMUKF0875-14M	7/8"	14	5	15.75	16.00	34.47	93.00	●
TMUK0875-9M	7/8"	9	4	15.75	16.00	36.75	93.00	●
TMUK1000-8M	1"	8	4	15.75	16.00	35.00	93.00	●
TMUKF1000-12M	1"-1 1/16"-1 1/8"-1 1/4"	12	5	15.75	16.00	33.87	93.00	●
TMUK1125-7M	1 1/8"	7	5	19.90	20.00	36.30	105.00	●
TMUK1375-6M	1 3/8"	6	5	19.90	20.00	38.10	105.00	●

Note - Shank with Weldon flat available over 6mm shank diameter, price and delivery on request

* Items marked with an asterisk are straight fluted

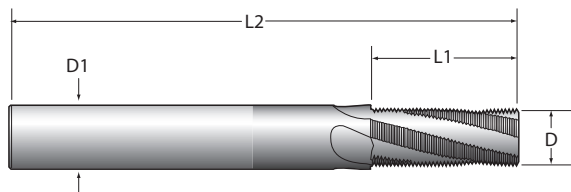
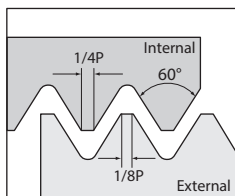

Solid Carbide Threadmills UN Extra Length

Part Number	Min. Thread Size	Thread per Inch	Flutes	Max Cutter Dia (D)	Shank Dia (D1)	Length of Cut (L1)	OAL (L2)	Stk.
				mm	mm	mm	mm	
TMUK0625-11XLM	5/8"	11	4	11.95	12.00	37.00	100.00	○
TMUK0750-10XLM	3/4"	10	4	11.95	12.00	40.70	100.00	○
TMUK0875-9XLM	7/8"	9	4	15.75	16.00	45.20	100.00	○
TMUK1000-8XLM	1"	8	6	19.90	20.00	50.80	115.00	○

Note - Shank with Weldon flat available, price and delivery on request

Note: Solid Carbide Threadmills are sold in packs of 1



+44 (0)1384 400 900



+44 (0)1384 400 105



enquiries@alliedmaxcut.com



www.alliedmaxcut.com

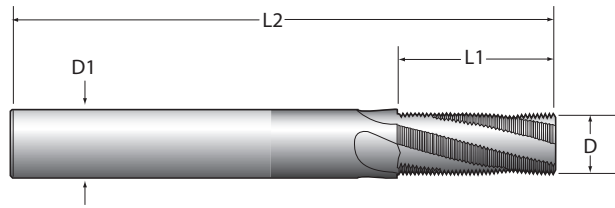
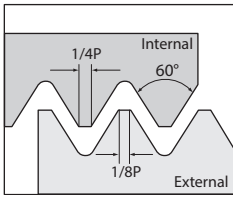

Solid Carbide Threadmills Metric

Part Number	Min. Thread Size	Pitch	Flutes	Max Cutter Dia (D)	Shank Dia (D1)	Length of Cut (L1)	OAL (L2)	Stk.
				mm	mm	mm	mm	
TMMK0200-040M*	M2	0.40	3*	1.50	3.00	3.20	39.00	●
TMMK0250-045M*	M2.5	0.45	3*	1.50	3.00	3.60	39.00	●
TMMK0300-050M*	M3	0.50	3*	2.15	3.00	4.50	39.00	●
TMMK0400-070M	M4	0.70	3	2.90	3.00	8.00	39.00	●
TMMK0450-075M	M4.5	0.75	3	3.00	4.00	6.75	51.00	●
TMMK0500-080M	M5	0.80	3	3.60	4.00	8.00	51.00	●
TMMK0600-100M	M6	1.00	3	4.60	6.00	12.00	51.00	●
TMMK0600-075M	M6	0.75	3	4.60	6.00	12.00	51.00	●
TMMK0600-050M	M6	0.50	3	4.60	6.00	12.00	58.00	●
TMMK0800-125M	M8	1.25	3	5.90	6.00	16.25	51.00	●
TMMK1000-150M	M10	1.50	4	7.40	8.00	19.50	64.00	●
TMMK1000-075M	M10	0.75	4	7.95	8.00	15.00	64.00	●
TMMK1000-050M	M10	0.50	4	7.95	8.00	15.00	64.00	●
TMMK1200-175M	M12	1.75	4	9.40	10.00	22.71	73.00	●
TMMK1200-100M	M12	1.00	4	9.40	10.00	20.00	73.00	●
TMMK1400-150M	M14	1.50	4	10.90	12.00	27.00	84.00	●
TMMK1400-200M	M14	2.00	4	10.90	12.00	28.00	84.00	●
TMMK1800-150M	M18	1.50	4	11.90	12.00	31.50	84.00	●
TMMK2000-250M	M20	2.50	4	11.90	12.00	30.00	84.00	●
TMMK2000-200M	M20	2.00	4	11.95	12.00	30.00	84.00	●
TMMKF2000-150M	M20-M22-M24	1.50	5	15.75	16.00	36.00	93.00	●
TMMK2400-300M	M24	3.00	4	15.90	16.00	36.00	93.00	●
TMMK3000-350M	M30	3.50	4	15.75	16.00	38.50	100.00	●
TMMK3600-400M	M36	4.00	5	19.90	20.00	40.00	105.00	●

Note - Shank with Weldon flat available over 6mm shank diameter, price and delivery on request

* Items marked with an asterisk are straight fluted

Stk. - Stock Availability

- Stocked.
- Stocked in limited quantities
- ◆ Non-Stocked Standard – 25 working days delivery
- All other coatings are non-stocked standards – 25 working day delivery applies

Made to order tool specification – Priced on Request

Fax a copy of the table below to the AMEC's Application Engineering Department +44 1384 408372 or email engineering@alliedmaxcut.com to receive pricing for a special thread mill

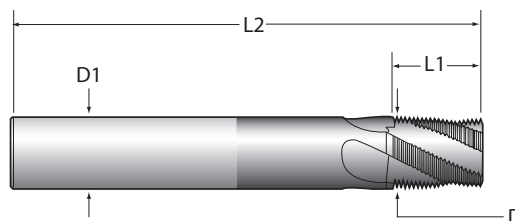

Thread Size	Thread Form	Pitch	# Flutes	Cutter Diameter (D)	Shank Diameter (D1)	Length of Cut (L1)	OAL (L2)	Flute Style	Coating	Qty
Company Name			Contact Name				Telephone		Fax	
Distributor Name			Distributor Contact Name				Telephone		Fax	

Note: Solid Carbide Threadmills are sold in packs of 1



AccuThread 856[®]

Indexable Threadmills Bolt-In Inserts Style UN
AM210[®] coated

T-A & GENZ T-A

GENSSYS

APX

Revolution & Core Drill

ASC 320 Solid Carbide

AccuPort 432

Criterion

Thread Milling

Special Tooling

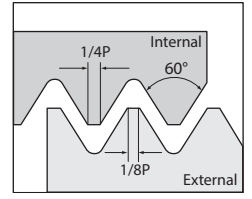
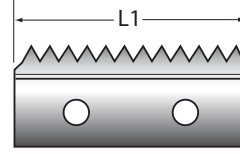
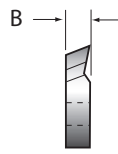

Bolt-In Style Inserts UN Internal

Part Number	Threads per Inch	Insert Length (L1)	Insert Thickness (B)	Stk.
		mm	mm	
TP075K-UN32I	32	19.05	2.03	●
TP075K-UN24I	24	19.05	2.03	●
TP075K-UN20I	20	19.05	2.03	●
TP075K-UN18I	18	19.05	2.03	●
TP075K-UN16I	16	19.05	2.03	●
TP100K-UN32I	32	25.40	3.56	●
TP100K-UN24I	24	25.40	3.56	●
TP100K-UN20I	20	25.40	3.56	●
TP100K-UN18I	18	25.40	3.56	●
TP100K-UN16I	16	25.40	3.56	●
TP100K-UN14I	14	25.40	3.56	●
TP100K-UN12I	12	25.40	3.56	●
TP100K-UN10I	10	25.40	3.56	●

Note: Indexable Threadmill Inserts are sold in packs of 2

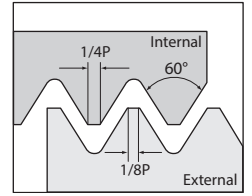
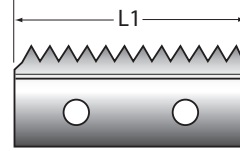
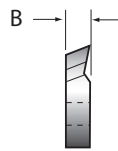

Bolt-In Style Inserts UN External

Part Number	Threads per Inch	Insert Length (L1)	Insert Thickness (B)	Stk.
		mm	mm	
TP075K-UN32E	32	19.05	2.03	◆
TP075K-UN24E	24	19.05	2.03	◆
TP075K-UN20E	20	19.05	2.03	◆
TP075K-UN18E	18	19.05	2.03	◆
TP075K-UN16E	16	19.05	2.03	◆
TP100K-UN32E	32	25.40	3.56	◆
TP100K-UN24E	24	25.40	3.56	◆
TP100K-UN20E	20	25.40	3.56	◆
TP100K-UN18E	18	25.40	3.56	◆
TP100K-UN16E	16	25.40	3.56	◆
TP100K-UN14E	14	25.40	3.56	◆
TP100K-UN12E	12	25.40	3.56	◆

Note: Indexable Threadmill Inserts are sold in packs of 2

Stk. - Stock Availability

- Stocked.
- Stocked in limited quantities
- ◆ Non-Stocked Standard – 25 working days delivery
All other coatings are non-stocked standards – 25 working day delivery applies



+44 (0)1384 400 900



+44 (0)1384 400 105



enquiries@alliedmaxcut.com



www.alliedmaxcut.com

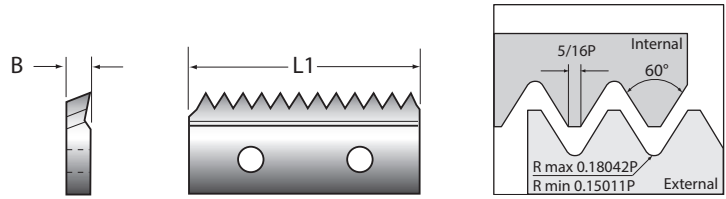

Bolt-In Style Inserts UNJ Internal

Part Number	Threads per Inch	Insert Length (L1)		Insert Thickness (B)		Stk.
		mm	mm	mm	mm	
TP075K-UNJ32I	32	19.05	19.05	2.03	2.03	◆
TP075K-UNJ24I	24	19.05	19.05	2.03	2.03	◆
TP075K-UNJ20I	20	19.05	19.05	2.03	2.03	◆
TP075K-UNJ18I	18	19.05	19.05	2.03	2.03	◆
TP075K-UNJ16I	16	19.05	19.05	2.03	2.03	◆
TP100K-UNJ32I	32	25.40	25.40	3.56	3.56	◆
TP100K-UNJ24I	24	25.40	25.40	3.56	3.56	◆
TP100K-UNJ20I	20	25.40	25.40	3.56	3.56	◆
TP100K-UNJ18I	18	25.40	25.40	3.56	3.56	◆
TP100K-UNJ16I	16	25.40	25.40	3.56	3.56	◆
TP100K-UNJ14I	14	25.40	25.40	3.56	3.56	◆
TP100K-UNJ12I	12	19.05	19.05	2.03	2.03	◆

Note: Indexable Threadmill Inserts are sold in packs of 2

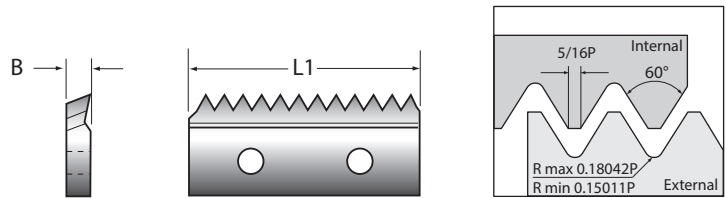

Bolt-In Style Inserts UNJ External

Part Number	Threads per Inch	Insert Length (L1)		Insert Thickness (B)		Stk.
		mm	mm	mm	mm	
TP075K-UNJ32E	32	19.05	19.05	2.03	2.03	◆
TP075K-UNJ24E	24	19.05	19.05	2.03	2.03	◆
TP075K-UNJ20E	20	19.05	19.05	2.03	2.03	◆
TP075K-UNJ18E	18	19.05	19.05	2.03	2.03	◆
TP075K-UNJ16E	16	19.05	19.05	2.03	2.03	◆
TP100K-UNJ32E	32	25.40	25.40	3.56	3.56	◆
TP100K-UNJ24E	24	25.40	25.40	3.56	3.56	◆
TP100K-UNJ20E	20	25.40	25.40	3.56	3.56	◆
TP100K-UNJ18E	18	25.40	25.40	3.56	3.56	◆
TP100K-UNJ16E	16	25.40	25.40	3.56	3.56	◆
TP100K-UNJ12E	12	25.40	25.40	3.56	3.56	◆

Note: Indexable Threadmill Inserts are sold in packs of 2

Stk. - Stock Availability

- Stocked.
 - Stocked in limited quantities
 - ◆ Non-Stocked Standard – 25 working days delivery
- All other coatings are non-stocked standards – 25 working day delivery applies



AccuThread 856[®]

Indexable Threadmills Metric/BSP and Holders
AM210[®] coated

T-A & GENZ T-A

GENSYS

APX

Revolution & Core Drill

ASC 320 Solid Carbide

AccuPort 432

Criterion

Thread Milling

Special Tooling

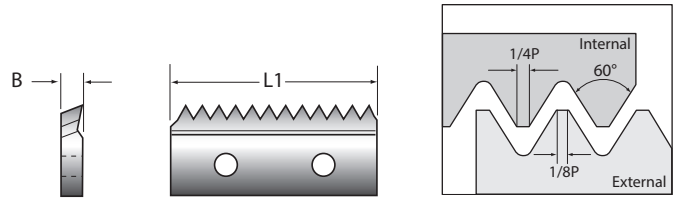

Bolt-In Style Inserts Metric Internal

Part Number	Pitch	Insert Length (L1)		Insert Thickness (B)		Stk.
		mm	mm	mm	mm	
TP075K-M0.5I	0.5	19.05	19.05	2.03	2.03	●
TP075K-M1.0I	1.0	19.05	19.05	2.03	2.03	●
TP075K-M1.25I	1.25	19.05	19.05	2.03	2.03	●
TP075K-M1.5I	1.5	19.05	19.05	2.03	2.03	●
TP100K-M1.0I	1.0	25.40	25.40	3.56	3.56	●
TP100K-M1.5I	1.5	25.40	25.40	3.56	3.56	●
TP100K-M2.0I	2.0	25.40	25.40	3.56	3.56	●

Note: Indexable Threadmill Inserts are sold in packs of 2

Bolt-In Style Inserts Metric External

Part Number	Pitch	Insert Length (L1)		Insert Thickness (B)		Stk.
		mm	mm	mm	mm	
TP100K-M1.0E	1.0	25.40	25.40	3.56	3.56	◆
TP100K-M1.5E	1.5	25.40	25.40	3.56	3.56	◆
TP100K-M2.0E	2.0	25.40	25.40	3.56	3.56	◆

Note: Indexable Threadmill Inserts are sold in packs of 2

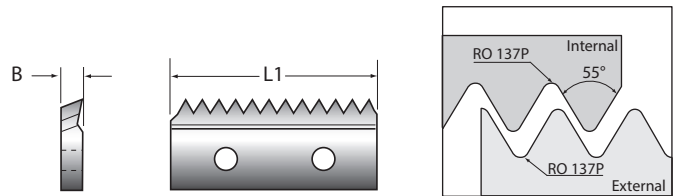

Bolt-In Style Inserts BSPP Internal & External

Part Number	Threads per Inch	Insert Length (L1)		Insert Thickness (B)		Stk.
		mm	mm	mm	mm	
TP075K-BSPP19	19	19.05	19.05	2.03	2.03	●
TP100K-BSPP14	14	25.40	25.40	3.56	3.56	●
TP100K-BSPP19	19	25.40	25.40	3.56	3.56	●

Note: Indexable Threadmill Inserts are sold in packs of 2

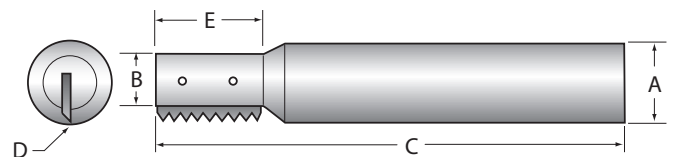

Straight Bolt-In Style UN/ISO/BSPP Internal & External

Part Number	Min. Thread Size	Shank Dia (A)	Pilot Dia (B)	OAL (C)	Cutter Dia (D)	Insert Length (E)	Flutes	Screw	Stk.
		mm	mm	mm	mm	mm			
THN-0394-IF075M	TP075K-UN/ISO/BSPP	13.00	6.35	76.20	10.01	19.05	1	TMS-250	●
THN-0625-1F100M	TP100K-UN/ISO/BSPP	20.00	11.58	88.90	15.88	25.40	1	TMS-40	●



+44 (0)1384 400 900



+44 (0)1384 400 105



enquiries@alliedmaxcut.com



www.alliedmaxcut.com

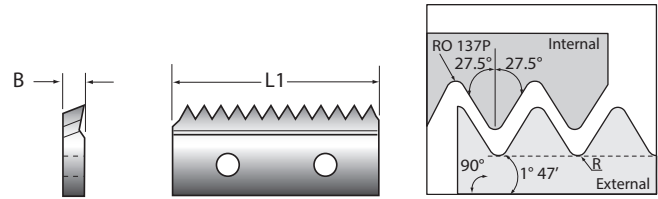

Bolt-In Style Inserts BSPT Internal & External

Part Number	Threads per Inch	Insert Length (L1)		Insert Thickness (B)		Stk.
		mm	mm	mm	mm	
TP075K-BSPT19	19	19.05	19.05	2.03	2.03	●
TP100K-BSPT14	14	25.40	25.40	3.56	3.56	●
TP100K-BSPT19	19	25.40	25.40	3.56	3.56	●

Note: Indexable Threadmill Inserts are sold in packs of 2

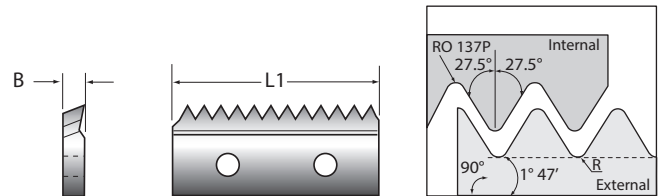

Bolt-In Style Inserts NPT/NPTF Internal & External

Part Number	Threads per Inch	Insert Length (L1)		Insert Thickness (B)		Stk.
		mm	mm	mm	mm	
TP075K-NPT18	18	19.05	19.05	2.03	2.03	●
TP075K-NPTF18	18	19.05	19.05	2.03	2.03	●
TP100K-NPT14	14	25.40	25.40	3.56	3.56	●
TP100K-NPTF14	14	25.40	25.40	3.56	3.56	●

Note: Indexable Threadmill Inserts are sold in packs of 2

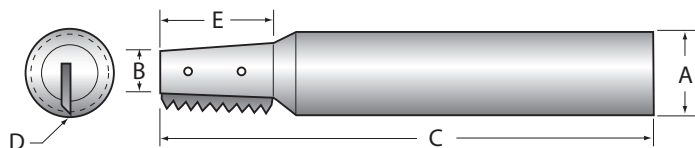

Threadmill Holders Tapered Bolt-In Style NPT/NPTF/BSPT Internal & External

Part Number	Stk.	Insert	Shank Dia (A)	Pilot Dia (B)	OAL (C)	Cutter Dia (D)	Insert Length (E)	Flutes	Screw
			mm	mm	mm	mm	mm		
THT-0400-1F075M	●	TP075K-NPT/NPTF/BSPT	13.00	5.82	76.20	10.16	19.05	1	TMS-250
THT-0659-1F100M	●	TP100K-NPT/NPTF/BSPT	13.00	9.65	76.20	16.74	25.40	1	TMS-45

Note: Indexable Threadmill Inserts are sold in packs of 2

Stk. - Stock Availability

- Stocked.
 - Stocked in limited quantities
 - ◆ Non-Stocked Standard – 25 working days delivery
- All other coatings are non-stocked standards – 25 working day delivery applies



AccuThread 856[®]

Indexable Threadmills Pin Style Inserts NPT/NPTF/BSP/BSPT/API
AM210[®] coated

T-A & GENZ T-A

GENSYS

APX

Revolution & Core Drill

ASC 320 Solid Carbide

AccuPort 432

Criterion

Thread Milling

Special Tooling

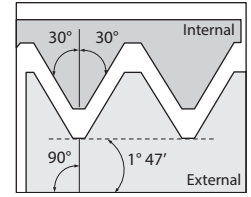
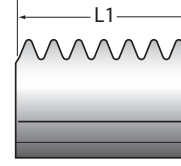
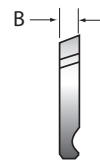

Pin Style Inserts NPT/NPTF Internal & External

Part Number	Threads per Inch	Insert Length (L1)		Insert Thickness (B)		Stk.
		mm	mm	mm	mm	
TN150K-NPT11.5	11.5	38.10		3.56		●
TN150K-NPTF11.5	11.5	38.10		3.56		●
TN150K-NPT8	8	38.10		3.56		●
TN150K-NPTF8	8	38.10		3.56		●

Note: Indexable Threadmill Inserts are sold in packs of 2

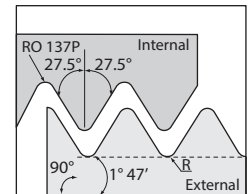
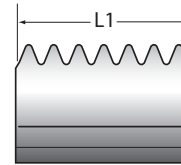
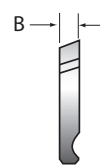
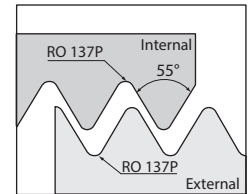

Pin Style Inserts BSPP/BSPT Internal & External

Part Number	Threads per Inch	Insert Length (L1)		Insert Thickness (B)		Stk.
		mm	mm	mm	mm	
TN150K-BSPP11	11	38.10		3.56		●
TN150K-BSPT11	11	38.10		3.56		●

Note: Indexable Threadmill Inserts are sold in packs of 2

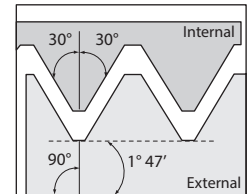
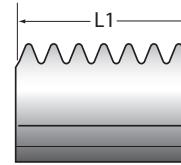
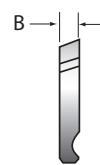

Pin Style Inserts API-ROUND Internal & External

Part Number	Threads per Inch	Insert Length (L1)		Insert Thickness (B)		Stk.
		mm	mm	mm	mm	
TN150K-AP10	10	38.10		3.56		○
TN150K-AP8	8	38.10		3.56		○

Note: Indexable Threadmill Inserts are sold in packs of 2



+44 (0)1384 400 900



+44 (0)1384 400 105



enquiries@alliedmaxcut.com



www.alliedmaxcut.com

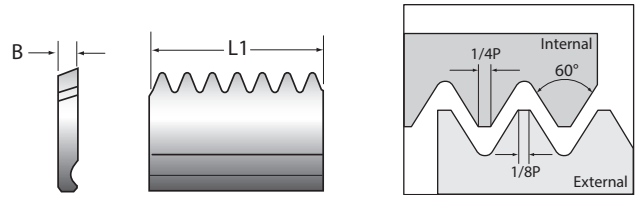

Pin Style Inserts UN (Internal)

Part Number	Threads per Inch	Insert Length (L1)		Insert Thickness (B)		Stk.
		mm	mm	mm	mm	
TN100K-UN32I	32	25.40	25.40	3.56	3.56	●
TN100K-UN24I	24	25.40	25.40	3.56	3.56	●
TN100K-UN20I	20	25.40	25.40	3.56	3.56	●
TN100K-UN18I	18	25.40	25.40	3.56	3.56	●
TN100K-UN16I	16	25.40	25.40	3.56	3.56	●
TN100K-UN12I	12	25.40	25.40	3.56	3.56	●
TN100K-UN10I	10	25.40	25.40	3.56	3.56	●
TN100K-UN8I	8	25.40	25.40	3.56	3.56	●
TN150K-UN24I	24	38.10	38.10	3.56	3.56	●
TN150K-UN20I	20	38.10	38.10	3.56	3.56	●
TN150K-UN18I	18	38.10	38.10	3.56	3.56	●
TN150K-UN16I	16	38.10	38.10	3.56	3.56	●
TN150K-UN14I	14	38.10	38.10	3.56	3.56	●
TN150K-UN12I	12	38.10	38.10	3.56	3.56	●
TN150K-UN10I	10	38.10	38.10	3.56	3.56	●
TN150K-UN8I	8	38.10	38.10	3.56	3.56	●
TN150K-UN7I	7	38.10	38.10	3.56	3.56	●
TN150K-UN6I	6	38.10	38.10	3.56	3.56	●

Note: Indexable Threadmill Inserts are sold in packs of 2

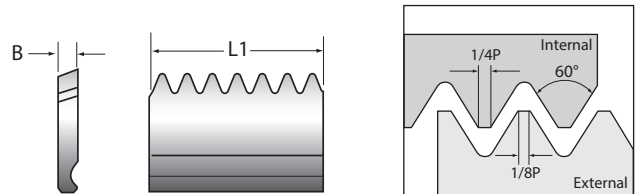

Pin Style Inserts UN (External)

Part Number	Threads per Inch	Insert Length (L1)		Insert Thickness (B)		Stk.
		mm	mm	mm	mm	
TN100K-UN32E	32	25.40	25.40	3.56	3.56	◆
TN100K-UN24E	24	25.40	25.40	3.56	3.56	◆
TN100K-UN20E	20	25.40	25.40	3.56	3.56	◆
TN100K-UN18E	18	25.40	25.40	3.56	3.56	◆
TN100K-UN16E	16	25.40	25.40	3.56	3.56	◆
TN100K-UN12E	12	25.40	25.40	3.56	3.56	◆
TN100K-UN10E	10	25.40	25.40	3.56	3.56	◆
TN100K-UN8E	8	25.40	25.40	3.56	3.56	◆
TN100K-UN7E	7	25.40	25.40	3.56	3.56	◆
TN150K-UN24E	24	38.10	38.10	3.56	3.56	◆
TN150K-UN20E	20	38.10	38.10	3.56	3.56	◆
TN150K-UN18E	18	38.10	38.10	3.56	3.56	◆
TN150K-UN16E	16	38.10	38.10	3.56	3.56	◆
TN150K-UN12E	12	38.10	38.10	3.56	3.56	◆
TN150K-UN10E	10	38.10	38.10	3.56	3.56	◆
TN150K-UN8E	8	38.10	38.10	3.56	3.56	◆
TN150K-UN7E	7	38.10	38.10	3.56	3.56	◆
TN150K-UN6E	6	38.10	38.10	3.56	3.56	◆

Note: Indexable Threadmill Inserts are sold in packs of 2



AccuThread 856[®]

Indexable Threadmills Pin Style UNJ
AM210[®] coated

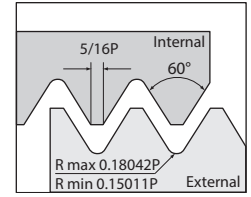
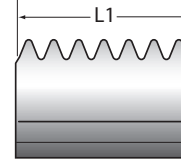
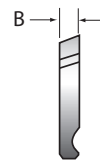

Pin Style Inserts UNJ (Internal)

Part Number	Threads per Inch	Insert Length (L1)		Insert Thickness (B)		Stk.
		mm	mm	mm	mm	
TN100K-UNJ32I	32	25.40		3.56		◆
TN100K-UNJ24I	24	25.40		3.56		◆
TN100K-UNJ20I	20	25.40		3.56		◆
TN100K-UNJ18I	18	25.40		3.56		◆
TN100K-UNJ16I	16	25.40		3.56		◆
TN100K-UNJ12I	12	25.40		3.56		◆
TN100K-UNJ10I	10	25.40		3.56		◆
TN150K-UNJ24I	24	38.10		3.56		◆
TN150K-UNJ20I	20	38.10		3.56		◆
TN150K-UNJ18I	18	38.10		3.56		◆
TN150K-UNJ16I	16	38.10		3.56		◆
TN150K-UNJ14I	14	38.10		3.56		◆
TN150K-UNJ12I	12	38.10		3.56		◆
TN150K-UNJ10I	10	38.10		3.56		◆
TN150K-UNJ8I	8	38.10		3.56		◆

Note: Indexable Threadmill Inserts are sold in packs of 2

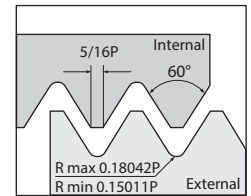
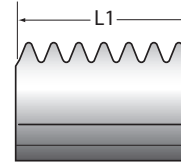
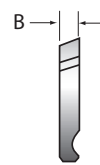

Pin Style Inserts UNJ (External)

Part Number	Threads per Inch	Insert Length (L1)		Insert Thickness (B)		Stk.
		mm	mm	mm	mm	
TN100K-UNJ32E	32	25.40		3.56		◆
TN100K-UNJ24E	24	25.40		3.56		◆
TN100K-UNJ20E	20	25.40		3.56		◆
TN100K-UNJ18E	18	25.40		3.56		◆
TN100K-UNJ16E	16	25.40		3.56		◆
TN100K-UNJ12E	12	25.40		3.56		◆
TN100K-UNJ10E	10	25.40		3.56		◆
TN150K-UNJ24E	24	38.10		3.56		◆
TN150K-UNJ20E	20	38.10		3.56		◆
TN150K-UNJ18E	18	38.10		3.56		◆
TN150K-UNJ16E	16	38.10		3.56		◆
TN150K-UNJ12E	12	38.10		3.56		◆
TN150K-UNJ10E	10	38.10		3.56		◆
TN150K-UNJ8E	8	38.10		3.56		◆

Note: Indexable Threadmill Inserts are sold in packs of 2



+44 (0)1384 400 900



+44 (0)1384 400 105



enquiries@alliedmaxcut.com



www.alliedmaxcut.com

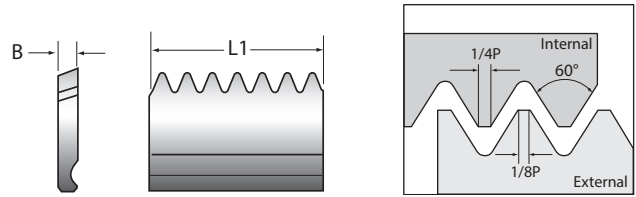

Pin Style Inserts Metric Internal

Part Number	Pitch	Insert Length (L1)		Insert Thickness (B)		Stk.
		mm		mm		
TN150K-M2.0I	2.0	38.10		3.56		●
TN150K-M2.5I	2.5	38.10		3.56		●
TN150K-M3.0I	3.0	38.10		3.56		●
TN150K-M3.5I	3.5	38.10		3.56		●
TN150K-M4.0I	4.0	38.10		3.56		●
TN150K-M4.5I	4.5	38.10		3.56		●
TN150K-M5.0I	5.0	38.10		3.56		●
TN150K-M6.0I	6.0	38.10		3.56		●

Note: Indexable Threadmill Inserts are sold in packs of 2

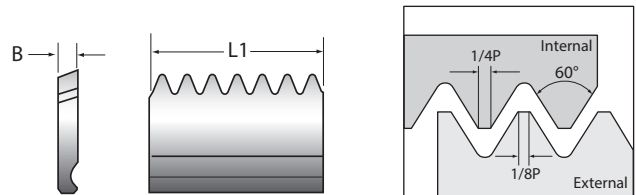

Pin Style Inserts Metric External

Part Number	Pitch	Insert Length (L1)		Insert Thickness (B)		Stk.
		mm		mm		
TN150K-M2.0E	2.0	38.10		3.56		○
TN150K-M4.0E	4.0	38.10		3.56		○
TN150K-M4.5E	4.5	38.10		3.56		○
TN150K-M5.0E	5.0	38.10		3.56		○
TN150K-M6.0E	6.0	38.10		3.56		○

Note: Indexable Threadmill Inserts are sold in packs of 2

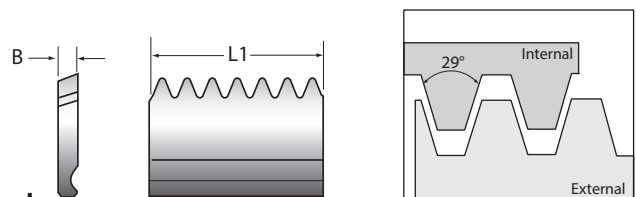

Pin Style Inserts (Full Profile) ACME Internal & External

Part Number	Threads per Inch	Insert Length (L1)		Insert Thickness (B)		Stk.
		mm		mm		
TN100K-FA12	12	25.40		3.56		○
TN100K-FA10	10	25.40		3.56		○
TN100K-FA8	8	25.40		3.56		○
TN150K-FA12	12	38.10		3.56		○
TN150K-FA10	10	38.10		3.56		○
TN150K-FA8	8	38.10		3.56		○
TN150K-FA6	6	38.10		3.56		○
TN150K-FA5	5	38.10		3.56		○

Note: Indexable Threadmill Inserts are sold in packs of 2



AccuThread 856[®]

Indexable Threadmill Pin Style Holders

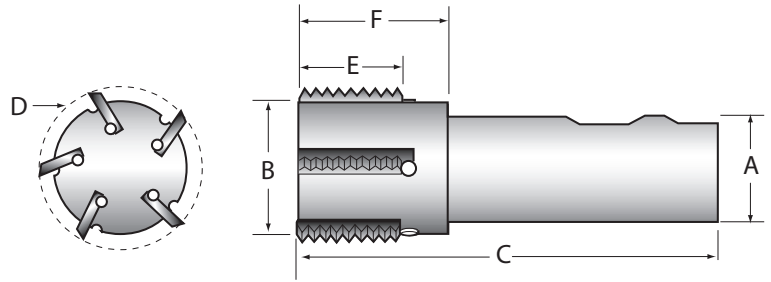

Pin Style Holders UN/NPT/ISO/ACME/API/NPTF/BSP & BSPT (Internal & External)

Part Number	Stk.	Insert Size	Coolant Port	Shank Dia (A)	Pilot Dia (B)	OAL (C)	Cutter Dia (UN) Straight (D)	Cutter Dia (NPT) Tapered (D)	Insert Length (E)	Flute Length (F)	Flutes	Screw	Pin
THP-0969-2F100M	●	TN100K-	N	25	19.05	114.3	24.61	-	25.4	35.05	2	TMSS-3	TMP-6
THP-1755-5F100M	●	TN100K-	Y	32	38.1	101.6	44.58	-	25.4	57.15	5	TMSS-2	TMP-1
THP-0932-1F150M	●	TN150K-	N	25	18.34	114.3	23.67	27.05	38.1	48.44	1	TMSS-2	TMP-2
THP-1116-3F150M	●	TN150K-	Y	25	20.63	114.3	28.35	31.67	38.1	50.8	3	TMSS-3	TMP-2
THP-1755-5F150M	●	TN150K-	Y	32	38.1	114.3	44.58	47.96	38.1	57.15	5	TMSS-2	TMP-2
THP-0969-2F150M	●	TN150K-	N	25	19.05	114.3	24.61	-	38.1	50.8	2	TMSS-3	TMP-6

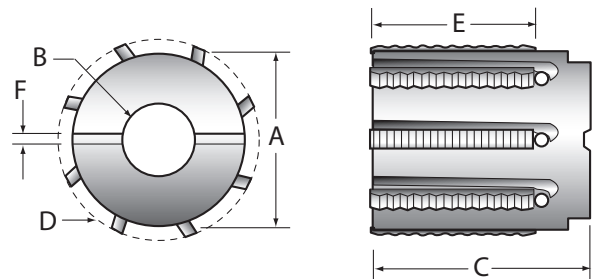

Pin Style Holders (Shell Mill) UN/ISO/ACME/BSP (Internal & External)

Part Number	Stk.	Insert Size	Body Dia (A)	Bore Dia (B)	OAL (C)	Cutter Dia (D)	Insert Length (E)	Slow Width (F)	Flutes	Screw	Pin
TSN-2846-7F150M	●	TN150K-	63.50	27.00	57.15	68.94*	38.10	12.70	7	TMSS-2	TMP-2
TSN-3341-8F150M	●	TN150K-	76.20	32.00	57.15	81.48*	38.10	14.00	8	TMSS-2	T

* For larger thread forms this diameter will change. Please refer to on-line programming at www.alliedmaxcut.com

T-A & GENZ T-A

GENSSYS

APX

Revolution & Core Drill

ASC 320 Solid Carbide

AccuPart 432

Criterion

Thread Milling

Special Tooling



+44 (0)1384 400 900



+44 (0)1384 400 105



enquiries@alliedmaxcut.com



www.alliedmaxcut.com

Technical Section - AccuThread 856[®]

Recommended Cutting Data
Solid Carbide Threadmills



Material	Material Hardness (BHN)	Material Machinability	AM210 [®] M/min	Cutter (mm)							
				Recommended Feed (mm/tooth)							
				3	5	6	8	10	12	16	19
Free Machining Steel	100-150	Easy	274	0.010	0.013	0.018	0.023	0.025	0.038	0.051	0.064
	150-200	Easy	213	0.010	0.013	0.018	0.023	0.025	0.038	0.051	0.064
	200-250	Easy	152	0.010	0.013	0.018	0.023	0.025	0.038	0.051	0.064
Low Carbon Steel	85-125	Average	274	0.010	0.013	0.018	0.023	0.025	0.038	0.051	0.064
	125-175	Average	213	0.010	0.013	0.018	0.023	0.025	0.038	0.051	0.064
	175-225	Average	183	0.010	0.013	0.018	0.023	0.025	0.038	0.051	0.064
	225-275	Average	152	0.010	0.013	0.018	0.023	0.025	0.038	0.051	0.064
Medium Carbon Steel	125-175	Average	175	0.010	0.013	0.015	0.020	0.025	0.033	0.046	0.051
	175-225	Average	152	0.010	0.013	0.015	0.020	0.025	0.033	0.046	0.051
	225-275	Average	137	0.010	0.013	0.015	0.020	0.025	0.033	0.046	0.051
	275-325	Average	122	0.010	0.013	0.015	0.020	0.025	0.033	0.046	0.051
Alloy Steel	125-175	Average	175	0.010	0.013	0.015	0.020	0.025	0.033	0.046	0.051
	175-225	Average	152	0.010	0.013	0.015	0.020	0.025	0.033	0.046	0.051
	225-275	Average	137	0.010	0.013	0.015	0.020	0.025	0.033	0.046	0.051
	275-325	Difficult	122	0.010	0.013	0.015	0.020	0.025	0.033	0.046	0.051
	325-375	Difficult	114	0.010	0.013	0.015	0.020	0.025	0.033	0.046	0.051
High Strength Alloy Steel	225-300	Average	137	0.010	0.013	0.015	0.020	0.025	0.033	0.046	0.051
	300-350	Difficult	122	0.010	0.013	0.015	0.020	0.025	0.033	0.046	0.051
	350-400	Difficult	107	0.010	0.013	0.015	0.020	0.025	0.033	0.046	0.051
Structural Steel	100-150	Average	183	0.010	0.013	0.018	0.023	0.025	0.038	0.051	0.064
	150-250	Average	152	0.010	0.013	0.018	0.023	0.025	0.038	0.051	0.064
	250-350	Difficult	137	0.010	0.013	0.018	0.023	0.025	0.038	0.051	0.064
Tool Steel	150-200	Difficult	175	0.010	0.013	0.018	0.023	0.025	0.038	0.051	0.064
	200-250	Difficult	152	0.010	0.013	0.018	0.023	0.025	0.038	0.051	0.064
High Temp Alloy	140-220	Difficult	37	0.008	0.010	0.015	0.020	0.023	0.025	0.030	0.038
	220-310	Difficult	27	0.008	0.010	0.015	0.020	0.023	0.025	0.030	0.038
Stainless Steel	135-185	Average	160	0.010	0.013	0.015	0.020	0.023	0.025	0.038	0.051
	185-275	Difficult	152	0.010	0.013	0.015	0.020	0.023	0.025	0.038	0.051
Stainless Steel PH	185-275	Average	91	0.010	0.013	0.015	0.020	0.023	0.025	0.038	0.051
	275-325	Difficult	46	0.010	0.013	0.015	0.020	0.023	0.025	0.038	0.051
Cast Iron	120-150	Easy	206	0.010	0.013	0.018	0.023	0.025	0.038	0.051	0.064
	150-200	Easy	191	0.010	0.013	0.018	0.023	0.025	0.038	0.051	0.064
	200-220	Easy	175	0.010	0.013	0.018	0.023	0.025	0.038	0.051	0.064
	220-260	Average	152	0.010	0.013	0.018	0.023	0.025	0.038	0.051	0.064
	260-320	Average	145	0.010	0.013	0.018	0.023	0.025	0.038	0.051	0.064
Aluminium, Wrought	30	Easy	335	0.013	0.015	0.023	0.025	0.038	0.051	0.064	0.076
	180	Easy	305	0.013	0.015	0.023	0.025	0.038	0.051	0.064	0.076
Cast Aluminium*	120	Easy	191	0.013	0.015	0.023	0.025	0.038	0.051	0.064	0.076
Brass	30-125	Easy	335	0.013	0.015	0.023	0.025	0.038	0.051	0.064	0.076

Formulas: Linear Feed Rate = RPM x mm/tooth x No. of Teeth M/min = (RPM x 3.142 x Dia)/1000. RPM = (M/min x 1000) / (Dia x 3.142)
Adjusted Feed Rate (AFR) for Internal Thread Milling = (Thread Major Dia – Cutter Dia) / major Dia x Linear Feed Rate

The above formula on an internal thread program adjusts the linear feed rate to be applied to the O.D. instead of the centre of the cutting tool. If the feed rate is not adjusted, the excessive feed rate will cause the thread mill cutting edges to fail.

Example of an Internal Thread Feed Rate Calculation: Cast Iron 125 BHN with a ½ - 13 thread form.

Step 1	Step 2	Step 3
RPM=(m/min x 1000)/(Dia x 3.142)	Linear Feed Rate = RPM x mm/tooth x No of teeth	AFR for Internal Thread Milling = (Major Dia-Cutter Dia) / Major Dia) x Linear Feed Rate
RPM=(152 x 1000)/(8.89 x 3.142)	Linear Feed Rate = 5442 x 0.038 x 4	AFR for Internal Thread Milling = (12.7 – 8.89) / 12.7) x 827.18
RPM=5442	Linear Feed Rate = 827.18 mm/min	AFR for Internal Thread Milling = 248.15mm/min

Note: Reduce feed and speed by 30% for NPT and NPTF Thread Forms due to tapered cutting action
* Uncoated thread mills are recommended for cast aluminium applications (price and availability upon request)
Refer to recommended pass chart on page 286 when referencing material machinability



Technical Section - AccuThread 856[®]

Recommended Cutting Data Indexable Threadmills

Material	Cutter Diameter (Metric)			9.53-12.7	12.70-19.05	19.05-25.40	25.40-38.10	38.10-50.80	50.80-69.85	69.85-88.90
	Number of Flutes			1	1	1&2	3	5	7	8
	Material Hardness (BHN)	Material Machinability	AM210 [®] M/min	Chipload per Tooth (mm per tooth)						
Free Machining Steel	100-150	Easy	274	0.02	0.03	0.03	0.04	0.05	0.06	0.08
	150-200	Easy	213	0.02	0.03	0.03	0.04	0.05	0.06	0.08
	200-250	Easy	152	0.02	0.03	0.03	0.04	0.05	0.06	0.08
Low Carbon Steel	85-125	Average	274	0.02	0.03	0.03	0.04	0.05	0.06	0.08
	125-175	Average	213	0.02	0.03	0.03	0.04	0.05	0.06	0.08
	175-225	Average	183	0.02	0.03	0.03	0.04	0.05	0.06	0.08
	225-275	Average	152	0.02	0.03	0.03	0.04	0.05	0.06	0.08
Medium Carbon Steel	125-175	Average	175	0.02	0.02	0.03	0.03	0.04	0.05	0.06
	175-225	Average	152	0.02	0.02	0.03	0.03	0.04	0.05	0.06
	225-275	Average	137	0.02	0.02	0.03	0.03	0.04	0.05	0.06
	275-325	Average	122	0.02	0.02	0.03	0.03	0.04	0.05	0.06
Alloy Steel	125-175	Average	175	0.01	0.02	0.03	0.03	0.04	0.05	0.06
	175-225	Average	152	0.01	0.02	0.03	0.03	0.04	0.05	0.06
	225-275	Average	137	0.01	0.02	0.03	0.03	0.04	0.05	0.06
	275-325	Difficult	122	0.01	0.02	0.03	0.03	0.04	0.05	0.06
	325-375	Difficult	114	0.01	0.02	0.03	0.03	0.04	0.05	0.06
High Strength Alloy Steel	225-300	Average	137	0.01	0.02	0.03	0.03	0.04	0.05	0.06
	300-350	Difficult	122	0.01	0.02	0.03	0.03	0.04	0.05	0.06
	350-400	Difficult	107	0.01	0.02	0.03	0.03	0.04	0.05	0.06
Structural Steel	100-150	Average	183	0.02	0.03	0.03	0.04	0.05	0.06	0.08
	150-250	Average	152	0.02	0.03	0.03	0.04	0.05	0.06	0.08
	250-350	Difficult	137	0.02	0.03	0.03	0.04	0.05	0.06	0.08
Tool Steel	150-200	Difficult	175	0.01	0.03	0.03	0.04	0.05	0.06	0.08
	200-250	Difficult	152	0.01	0.03	0.03	0.04	0.05	0.06	0.08
High Temp Alloy	140-220	Difficult	37	0.01	0.02	0.02	0.03	0.04	0.05	0.06
	220-310	Difficult	27	0.01	0.02	0.02	0.03	0.04	0.05	0.06
Stainless Steel	135-185	Average	160	0.01	0.02	0.02	0.04	0.04	0.05	0.06
	185-275	Difficult	152	0.01	0.02	0.02	0.04	0.04	0.05	0.06
Stainless Steel PH	185-275	Average	91	0.01	0.02	0.02	0.04	0.04	0.05	0.06
	275-325	Difficult	46	0.01	0.02	0.02	0.04	0.04	0.05	0.06
Cast Iron	120-150	Easy	206	0.02	0.03	0.04	0.05	0.08	0.10	0.13
	150-200	Easy	191	0.02	0.03	0.04	0.05	0.08	0.10	0.13
	200-220	Easy	175	0.02	0.03	0.04	0.05	0.08	0.10	0.13
	220-260	Average	152	0.02	0.03	0.04	0.05	0.08	0.10	0.13
	260-320	Average	145	0.02	0.03	0.04	0.05	0.08	0.10	0.13
Aluminium, Wrought	30	Easy	335	0.04	0.05	0.06	0.08	0.10	0.13	0.15
	180	Easy	305	0.04	0.05	0.06	0.08	0.10	0.13	0.15
Cast Aluminium*	120	Easy	191	0.03	0.05	0.06	0.08	0.10	0.13	0.15
Brass	30-125	Easy	335	0.05	0.06	0.08	0.10	0.11	0.14	0.17

Formulas: Linear Feed Rate = RPM x mm/tooth x No. of Teeth M/min = (RPM x 3.142 x Dia)/1000. RPM = (M/min x 1000) / (Dia x 3.142)
 Adjusted Feed Rate (AFR) for Internal Thread Milling = (Thread Major Dia – Cutter Dia) / major Dia x Linear Feed Rate

The above formula on an internal thread milling program adjusts the linear feed rate to be applied to the O.D. instead of the centre of the cutting tool. If the feed rate is not adjusted, the excessive feed rate will cause the thread mill cutting edges to fail.

Note: Reduce feed and speed by 30% for NPT and NPTF Thread Forms due to tapered cutting action
 * Uncoated thread mills are recommended for cast aluminium applications (price and availability upon request)
 Refer to recommended pass chart on page 286 when referencing material machinability

- Thread Milling can be easily accomplished with simple G code programming
- If your machine is capable of 3 axis (Helical) Interpolation, you can and should be thread milling
- Basic programming of a one pass thread mill can be achieved in 6 basic steps (see below)

The following are examples of how to calculate and program a 7/16-20 right hand thread that will be 1/2" deep and produced in one pass

Maj. Thread Diameter (mm)	11.112	Major diameter of thread ($7/16 = 0.4375$ ")
Threads Per Inch	20	Number of threads per inch (20 is from $7/16$ -20 designation)
Length of Thread (mm)	12.7	Desired length of thread
M/min Surface Speed	145	Recommended surface speed for material to be cut
Feed Per Flute (mm/tooth)	0.0635	Recommended feed rate per cutting edge
Number of Flutes	4	Number of flutes on tool to be used
Tool Diameter (mm)	8.509	Diameter of cutting tool

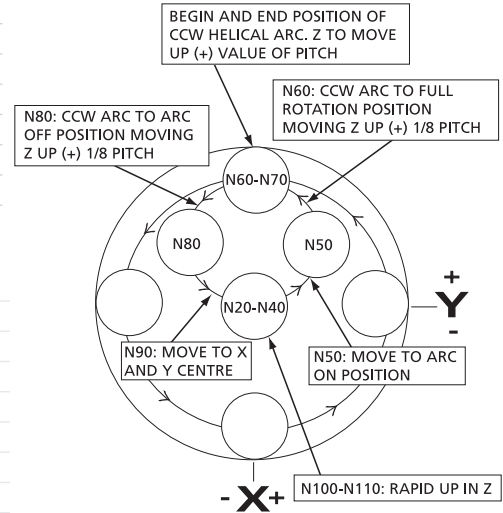

Using the information below, the values can be calculated

Pitch (mm)	1.27	= 25.4/Threads Per Inch
RPM	5419	(m/min / Tool Dia) x 318
Linear Feed (mm/min)	1376.43	RPM x Feed Per Flute x Number of Flutes
Feed Rate for Thread Milling	322.43	Linear Feed x (Maj Thread Dia – Tool Dia) / Maj Thread Dia
Z axis move for full thread	12.86	(Pitch / 8) + Length Of Thread
Z axis move on Arc On	0.16	(Pitch / 8)
Arc On/Off Value	0.650	(Maj Thread Dia – Tool Dia) / 4
Full Rotation Value	1.302	(Maj Thread Dia – Tool Dia) 2

Maj Thread Dia.	11.112	Feed Rate For Thread Milling	322.43	Arc On/Off	0.65
Cutter Diameter	8.509	Z axis Depth for Full Thread	12.86	Full Rotation Value	1.302
Length Of Thread	12.7	Z axis Move for Arc On/Off	0.16	Pitch Value	1.27

Incremental Program for 1 Pass Thread Mill

```

1  N10  S 5416 MO3
   N20  G90 G00 X 0.0000 Y 0.0000
   N30
2  N40  G91 G01 Z -12.860 F 1270
   N50  G41 G01 X 0.650 Y 0.650 D1 F 80.600
   N60  G03 X -0.650 Y 0.650 Z 0.160 I -0.650 J 0.00 F 322.43
   N70  G03 X 0.0000 Y 0.0000 Z 1.270 I 0.000 J -1.302 F 322.43
   N80  G03 X -0.650 Y -0.650 Z 0.160 I 0.000 J -0.650 F 644.12
   N90  G40 G01 X 0.650 Y -0.650
   N100 G00 Z 11.270
   N110 G90 G00 Z 25.000
    
```

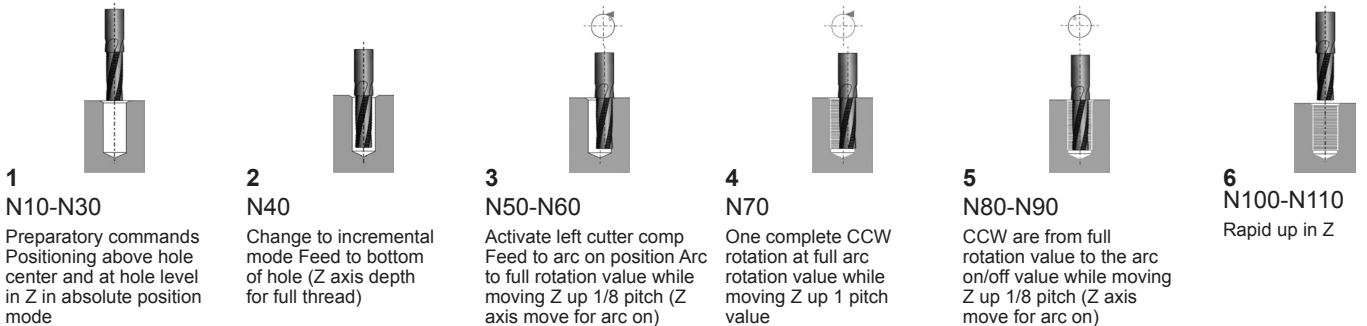



Technical Section

Pass Chart & Threadmilling Formulas

T-A & GENZ T-A
GENSYS
APX
Revolution & Core Drill
ASC 320 Solid Carbide
AccuPort 432
Criterion
Thread Milling
Special Tooling

Number of Passes NPT/NPTF			
Thread Size	Materials		
	Easy to Machine	Average to Machine	Difficult to Machine
1/16 NPT	1	1	2
1/8 NPT	1	1	2
1/4 NPT	1	1	2
3/8 NPT	1	1	2
1/2 NPT	1	2	3
3/4 NPT	1	2	3
1 NPT	1	2	3
1-1/4 NPT	1	2	3
1-1/2 NPT	1	2	3
2 NPT	1	2	3
2-1/2 NPT	2	3	4
3 NPT	2	3	4
3-1/2 NPT	2	3	4
4 NPT	2	3	4
5 NPT	2	3	4
6 NPT	2	3	4

Number of Passes Metric (ISO)			
Thread Size	Materials		
	Easy to Machine	Average to Machine	Difficult to Machine
M4.5 x .75	1	1	2
M5 x .80	1	1	2
M6 x .75	1	1	2
M6 x 1.0	1	1	2
M8 x .75	1	2	3
M8 x 1.25	1	2	3
M10 x 1.0	1	2	3
M10 x 1.5	1	2	3
M12 x 1.0	1	2	3
M12 x 1.75	1	2	3
M14 x 1.5	1	2	3
M14 x 2.0	1	2	3
M16 x 1.0	1	2	3
M16 x 2.0	1	2	3
M18 x 1.5	1	2	3
M18 x 2.0	1	2	3
M18 x 2.5	2	3	4
M20 x 2.5	2	3	4
M24 x 3.0	2	3	4
M30 x 3.5	2	3	4
M27 x 3.0	2	3	4
M33 x 3.5	2	3	4
M33 x 4.5	2	3	4
M36 x 4.0	2	3	4
M39 x 5.0	2	3	4
M39 x 4.0	2	3	4
M45 x 4.5	2	3	4
M52 x 5.0	2	3	4
M56 x 5.5	2	3	4

Threadmill Drill Calculation

Inch
Based on nominal tap drill diameter. Based on .003" or .0075mm probable mean oversize
To calculate percent of full thread for given hole diameter:
% Thread = No of Threads per Inch x (Basic Major Dia of thread (Inch) - Drill Hole Size (Inch)) / 0.0130

Metric
% Thread = $\frac{76.93}{\text{Pitch (mm)}} \times (\text{Basic Major Diameter of thread (mm)} - \text{Drill Hole Size (mm)})$

Number of Passes UN			
Thread Size	Materials		
	Easy to Machine	Average to Machine	Difficult to Machine
#2-56	1	1	2
#4-40	1	1	2
#5-40	1	1	2
#6-32	1	1	2
#8-32	1	1	2
#10-32	1	1	2
#10-24	1	1	2
#12-28	1	1	2
#12-24	1	1	2
1/4-28	1	2	3
1/4-20	1	2	3
5/16-24	1	2	3
5/16-18	1	2	3
3/4-24	1	2	3
3/8-16	1	2	3
7/16-20	1	2	3
7/16-14	1	2	3
1/2-20	1	2	3
1/2-13	1	2	3
9-16-18	1	2	3
9-16-2	1	2	3
5/8-18	1	2	3
5/8-11	2	2	4
3/4-16	1	2	3
3/4-10	2	3	4
7/8-14	1	2	3
7/8-9	2	3	4
1-14	1	2	3
1-10	2	3	4
1-8	2	2	4
1-1/8-7	2	3	4
1-1/4-7	2	3	4
1-3/8-6	2	3	4
1-1/2-6	2	3	4
1-3/4-5	2	3	4
2-4 1/2	2	3	4
1-1/4-4 1/2	2	3	4
2-1/2-4	2	3	4
25-3/4-4	2	3	4
3-4	2	3	4

Easy Machining Materials: Non-ferrous and leaded steels
Average Machining Materials: Carbon and alloy steels up to 30 Rc, 300 and 400 series stainless
Difficult Machining Materials: Inconels, harder steels, titanium, 17-4PH Stainless

Thread Milling Formulas

Linear Feed Rate = RPM * (mm/tooth x No of flutes)
M/min = (RPM x 3.142 x DIA/1000)
RPM = (m/min x 1000)/DIA x 3.142
AFR = (Major Diameter - Cutter Diameter) / Major Diameter * Linear Feed Rate
Arc On/Off Value = (Major Diameter - Tool Diameter) / 4
2 Axis Move Full Thread = (Pitch / 8) + Length of Thread
2 Axis Move Arc On = (Pitch / 8)

ANC Threads (60°) Major Thread Dia for # Drills					
#2	2.18	#5	3.18	#10	4.83
#3	2.51	#6	3.51	#12	5.49
#4	2.84	#8	4.17		

Technical Section

Thread Specification and Drill Chart



Thread Specification	Uses this drill	Closest Fraction	Decimal Inches
2-56	50	-	0.0700
3-56	45	-	0.0820
4-40	43	3/32"	0.0890
1/4-40	38	-	0.1015
5-40	38	-	0.1015
6-40	33	-	0.1130
M4x0.7	3.4mm	-	0.133
M4x0.75	3.4mm	-	0.1338
8-32	29	-	0.1360
8-40	28	-	0.1405
3/16-24	26	-	0.1470
10-24	25	5/32"	0.1495
3/16-32	22	-	0.1570
10-32	21	5/32"	0.1590
M5-0.8	4.2mm	-	0.1653
M5-0.9	4.3mm	-	0.1693
12-24	16	11/64"	0.1770
12-28	14	3/16"	0.1820
12-32	13	-	0.1850
14-20	10	-	0.1935
1/4-20	7	13/64"	0.2010
14-24	7	-	0.2010
M6-1.0	5.2mm	-	0.2047
1/4-24	4	-	2090
1/4-28	3	7/32"	0.2130
1/4-32	7/32"	7/32"	0.2188
1/4-40	1	-	0.2280
M7-1.0	6.1mm	15/64"	0.2401
5/16-18	F	17/64"	0.2570
M8-1.25	6.9mm	17/64"	0.2716
5/16-24	I	-	0.2720
M8-1.0	7.1mm	-	0.2795
5/16-32	9/32"	9/32"	0.2812
M9-1.25	7.9mm	-	0.3110
3/8-16	5/16"	5/16"	0.3125
M9-1.0	8.1mm	-	0.3189
M9-0.75	8.3mm	-	0.3268
3/8-24	Q	21/64"	0.3320
M10-1.5	8.7mm	-	0.3425
M10-1.25	8.9mm	11/32"	0.3503
M10-1.0	9.1mm	-	0.3583
7/16-14	U	23/64"	0.3680
M11-1.5	9.7mm	-	0.3818
7/16-20	25/64"	25/64"	0.3906
M12-1.75	10.5mm	-	0.4133
M12-1.5	10.7mm	27/64"	0.4212
1/2-13	27/64"	27/64"	0.4291
M12-1.25	10.9mm	27/64"	0.4291

Thread Specification	Uses this drill	Closest Fraction	Decimal Inches
1/2-20	29/64"	29/64"	0.4531
1/2-24	29/64"	29/64"	0.4531
M14-2.0	12.2mm	-	0.4803
9/16-12	31/64"	31/64"	0.4844
M14-1.5	12.7mm	-	0.4999
M14-1.25	12.8mm	-	0.5039
5/16-18	33/64"	33/64"	0.5156
5/8-11	17/32"	17/32"	0.5312
M16-2.0	14.2mm	35/64"	0.5590
5/8-18	37/64"	37/64"	0.5781
M16-1.5	14.7mm	-	0.5787
11/16-11	19/32"	19/32"	0.5938
M18-2.5	15.8mm	39/64"	0.5220
11/16-16	5/8"	5/8"	0.6250
3/4-10	21/32"	21/32"	0.6562
M18-1.5	16.8mm	-	0.6614
3/4-16	11/16"	11/16"	0.6875
M20-2.5	17.8mm	11/16"	0.7008
7/8-9	49/64"	49/64"	0.7656
7/8-14	13/16"	13/16"	0.8125
M22-1.5	20.9mm	-	0.8228
7/8-18	53/64"	53/64"	0.8281
M24-3.0	21.4mm	53/64"	0.8425
1-8	7/8"	7/8"	0.8750
M24-2.0	22.3mm	-	0.8779
1-12	59/64"	59/64"	0.9219
1-14	15/16"	15/16"	0.9375
1-1/8-7	63/64"	63/64"	0.9844
1-1/8-12	1-3/64"	1-3/64"	1.0469
1-1/4-7	1-7/64"	1-7/64"	1.1094
1-1/4-12	1-11/64"	1-11/64"	1.1719
1-3/8-6	1-7/32"	1-7/32"	1.2188
1-3/8-12	1-19/64"	1-19/64"	1.2969
1-1/2-6	1-11/32"	1-11/32"	1.3438
1-1/2-12	1-27/64"	1-27/64"	1.4219

Major Thread Diameter for # Drills

Thread Specification	Uses this drill	Closest Fraction	Decimal Inches
1/8-27 NPT	R	-	0.3390
1/4-18 NPT	7/16"	7/16"	0.4375
3/8-18 NPT	37/64"	37/64"	0.5781
1/2-14 NPT	45-64"	45/64"	0.7031
3/4-14 NPT	59/64"	59/64"	0.9219
1-11-1/2 NPT	1-5/32"	1-5/32"	1.1562
1-1/4-11.5 NPT	1-1/2"	1-1/2"	1.5000
1-1/2-11.5 NPT	1-47/64"	1-47/64"	1.7344
2-11.5 NPT	2-7/32"	2-7/32"	2.2188

Threadmill Drill Calculation

Based on nominal tap drill diameter. Based on .003" or 0.075mm probable mean oversize.

To calculate percent of full thread for a given hole diameter

$$\text{\% Thread} = \# \text{ of Threads per Inch} \times \left\{ \frac{\text{Basic Major Diameter Of thread (inch)} - \text{Drill Hole Size (inch)}}{0.0130} \right\}$$

$$\text{\% Thread} = \frac{76.93}{\text{Pitch (mm)}} \times \left\{ \frac{\text{Basic Major Diameter Of thread (mm)} - \text{Drill Hole Size (mm)}}{0.0130} \right\}$$



Technical Section

Thread Milling methods

External

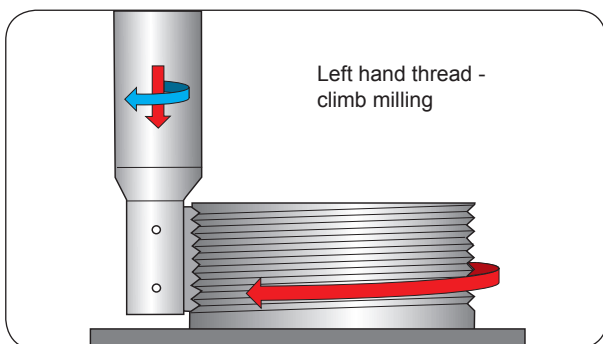
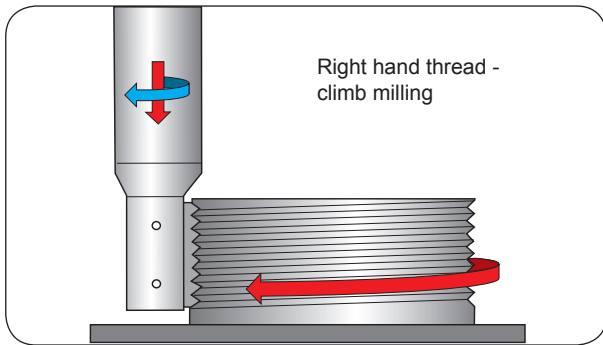
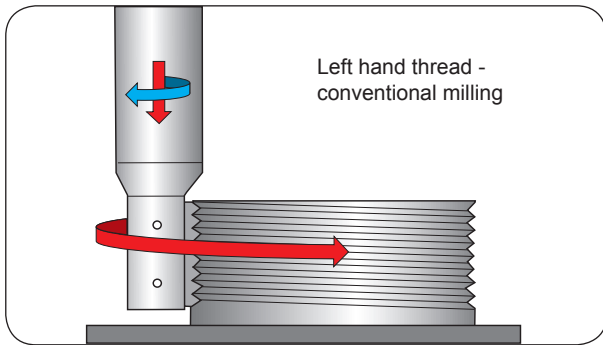
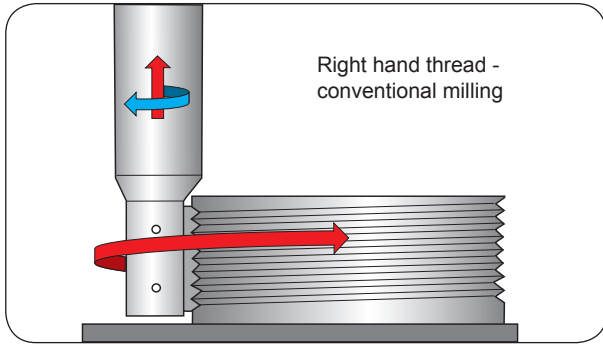

Internal

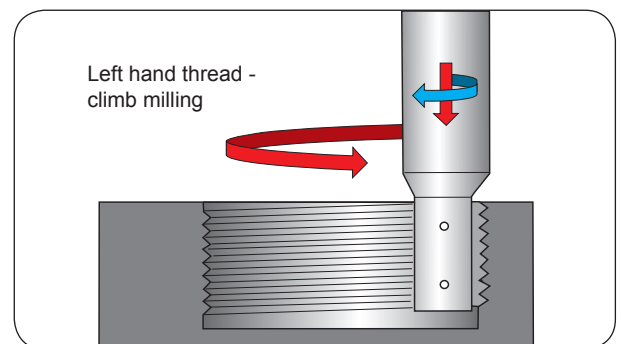
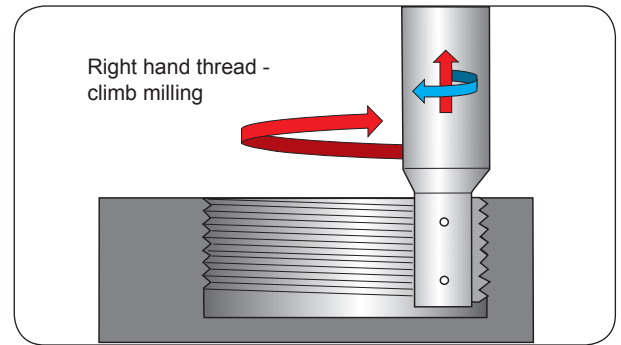
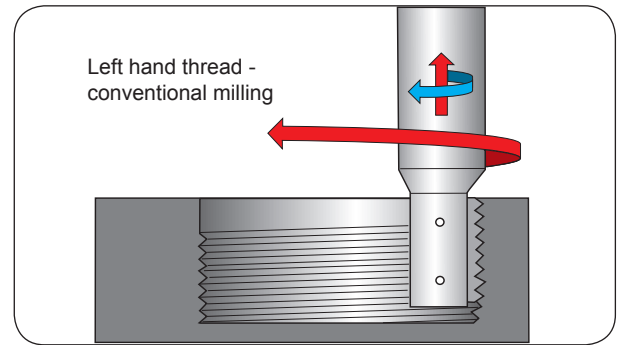
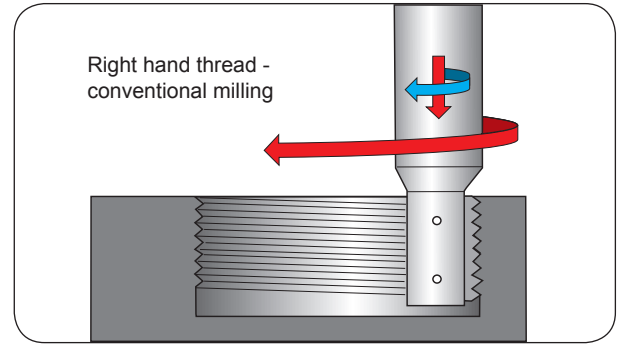

T-A & GENZ T-A

GENSYS

APX

Revolution & Core Drill

ASC 320 Solid Carbide

AccuPort 432

Criterion

Thread Milling

Special Tooling

G codes (ISO) for CNC Programme

Code	Description	Code	Description
%	Recognition Code (ISO or EIA), +End of tape	H	Tool length compensation number
G00	Rapid Traverse	D	Tool radius compensation number
G01	Linear interpolation	X	X coordinate
G02	Circular/Helical interpolation CW	Y	Y coordinate
G03	Circular/Helical interpolation CCW	Z	Z coordinate
G40	Cutter radius compensation cancel	R	Radius of travel
G41	Cutter radius compensation left	I	X coordinate to centre of starting arc travel
G42	Cutter radius compensation right	J	Y coordinate to centre of starting arc travel
G43	Tool length compensation +	M3	Spindle clockwise rotation
G49	Tool length compensation cancel	M5	Spindle stop
G57	Work coordinate system selection	M30	Programme end & rewind
G90	Absolute command relative to work coordinate origin	O	Programme number
G91	Incremental command relative to tool position	N	Block number (can be avoided)
F	Feed mm/min	(Start of comment
S	Spindle speed RPM)	End of comment

Troubleshooting guide

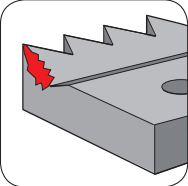
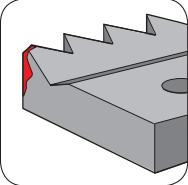
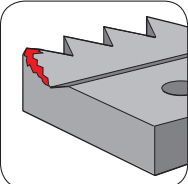
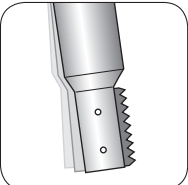
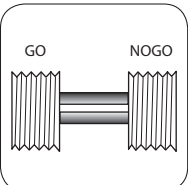
Problem	Possible cause	Solution
 <p>Increased insert flank wear</p>	<p>Cutting speed too high</p> <p>Chip is too thin</p> <p>Insufficient coolant</p>	<p>.....> Reduce cutting speed</p> <p>.....> Increase feed rate</p> <p>.....> Increase coolant flow rate</p>
 <p>Chipping of cutting edge</p>	<p>Chip is too thick</p> <p>Vibration</p>	<p>.....> Reduce feed rate / use the tangential arc method / increase RPM</p> <p>.....> Check stability</p>
 <p>Material build up on the cutting edge</p>	<p>Incorrect cutting speed</p>	<p>.....> Change cutting speed</p>
 <p>Chatter/vibration</p>	<p>Feed rate is too high</p> <p>Profile is too deep</p> <p>Thread length is too long</p>	<p>.....> Reduce the feed</p> <p>.....> Execute two passes, each with increased cutting depth / Execute two passes, each cutting only half the thread length</p> <p>.....> Execute two passes, each cutting only half the thread length</p>
 <p>Insufficient thread accuracy</p>	<p>Tool deflection</p>	<p>.....> Reduce feed rate / execute a "ZERO" cut</p>



Technical Section

Troubleshooting Guide

T-A & GENZ T-A
GENSYS
APX
Revolution & Core Drill
ASC 320 Solid Carbide
AccuPort 432
Criterion
Thread Milling
Special Tooling

Thread Mill is showing accelerated or excessive wear
Cutting edges are chipping
Thread mill is breaking in the first hole or part
Thread mill is creating excessive chatter
Out of round thread is produced
Bell mouthed thread is (small at bottom, big at top)
Part rejection because of rough flank insert
Steps in thread profile
Gauge difference from part to part
Machine not making correct paths to create thread profile
Control not accepting the program

	Thread Mill is showing accelerated or excessive wear	Cutting edges are chipping	Thread mill is breaking in the first hole or part	Thread mill is creating excessive chatter	Out of round thread is produced	Bell mouthed thread is (small at bottom, big at top)	Part rejection because of rough flank insert	Steps in thread profile	Gauge difference from part to part	Machine not making correct paths to create thread profile	Control not accepting the program
Catalogue	Incorrect tool selection		1	1							
	Incorrect speed and feed selection	2,3	2,3		2,3		2,3				
Speed and Feed	RPM too high	5									
	RPM too low			4		4	4				
	Machine tool specifications restricts RPM's			5,19							
	Feed rate too high		7	7		7	7	7			
	Feed rate too low	6									
	Incorrect adjusted feed rate adjustment ratio			12							
	Machine tool specification restrict feed rate				7,19						
	Ramp-in is programmed as an axial move			20				20			
Tool	Thread mill moved or slipped in its holding device	13	13	13	13		13	13			
	Tool is sticking out of the holder too far	15	15	15	15		15	15	15		
	Run out between thread mill and holder				10		10				
	Incorrect coating creating built up edge	8,17							8,17		
	Helix angle too low			9			9				
	Excessive thread mill wear							11	11		
	Excessive tool pressure	7,11,14				7,11,14					
Machine	Work piece moving in its fixturing	16	16	16	16		16		16		
	Insufficient coolant pressure or flow	17	17								
	Lack of machine rigidity	16	16		16	16	16				
Programming	Incorrect number of passes			22		22					
	Incorrect program variables			18,26					18,26		
	Didn't account for X/Y radial moves for tapered threads								24,26		
	Incorrect cutter compensation variables			23,26							23,26
	Helical interpolation option not on machine or turned "off"								21,26	21,26	
	Machine tool control is not formatted to standard EIA/ASC11/ISO Code										25,26

- Refer to the catalogue to ensure proper tool selection.
- Verify the correct speed was selected from the catalogue speed and feed chart.
- Verify the correct feed rate was selected from the catalogue speed and feed chart.
- Increase the spindle speed (RPM)
- Decrease the spindle speed (RPM)
- Increase the feed per tooth (mmpt)
- Decrease the feed per tooth (mmpt)
- Investigate other coatings
- Increase the tool helix.
- Gauge run out between thread mill and tool holder.
- Perform tool change at quicker intervals.
- Adjust the feed rate ratio properly to the correct actual penetration rate for internal threads. Refer to page 286 for formula.
- Use hydraulic clamping chuck.
- Check the tool for excessive wear, beginning threads will wear the fastest.
- Make the amount of overhang in the holding device as short as possible.
- Verify the work piece is being properly clamped, retighten or increase stability if necessary
- Increase the coolant flow and volume
- Check the milling program variables, especially the positive or negative value associated with I and J values.
- Make sure the machine tool has the appropriate axis and path speed capabilities.
- Make sure the thread mill is arcing in the major diameter instead of making a radial move.
- Make sure the machine tool had helical interpolation option and that is "on".
- Increase the number of thread mill passes.
- Make sure the cutter comparison variables are input into the G41.
- Adjust the program for pipe tap threads to taper out on diameter in X/Y directions to create proper form.
- Request information from the machine tool builder regarding its programming formats.
- Fax a copy of your programme to Allied Maxcut Engineering Department at (+44) 1384 408372 or e-mail engineering@alliedmaxcut.com

