

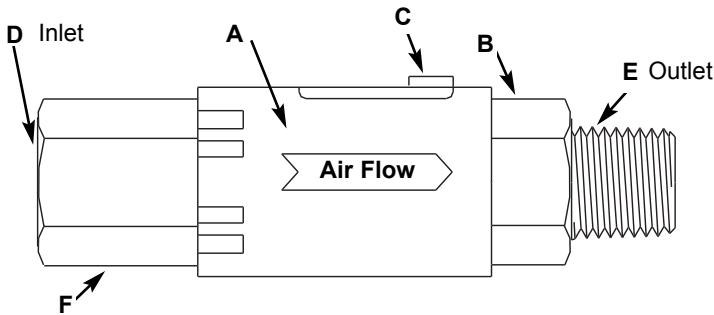

## Installation and Operation Instructions

(Use diagram at bottom of page as a guide)

1. Apply a small amount of seal compound to male threads of regulator and male threads of connector.
2. Engage regulator hex (B) with wrench and connect male outlet threads (E) to female inlet threads of tool.  
**Note: Adding a 6" snubber (whip hose) between the air tool and regulator will provide a safer and longer lasting installation.**
3. Engage regulator hex (F) with wrench and connect female inlet threads (D) to male threads of connector.
4. Engage connector to coupler of air supply line and apply pressure.
5. Loosen screw (C) and slide sleeve (A) toward tool and regulator outlet.
6. To adjust regulator to desired setting, turn hex (F) "out" to increase pressure or "in" to reduce pressure.
7. When desired pressure setting is reached, slide sleeve (A) back to original position by aligning the crest of the hex (F) and notch of the sleeve.
8. Tighten screw (C) to lock in at desired pressure setting.



East/Central: 19 Kimberly Road • East Brunswick, NJ 08816  
Phone: 732-390-8480 / Fax: 732-390-9693

West: 1730 NE Miller Street • McMinnville, OR 97128  
Phone: 503-434-5964 / Fax: 503-472-1989

## Installation and Operation Instructions

(Use diagram at bottom of page as a guide)

1. Apply a small amount of seal compound to male threads of regulator and male threads of connector.
2. Engage regulator hex (B) with wrench and connect male outlet threads (E) to female inlet threads of tool.  
**Note: Adding a 6" snubber (whip hose) between the air tool and regulator will provide a safer and longer lasting installation.**
3. Engage regulator hex (F) with wrench and connect female inlet threads (D) to male threads of connector.
4. Engage connector to coupler of air supply line and apply pressure.
5. Loosen screw (C) and slide sleeve (A) toward tool and regulator outlet.
6. To adjust regulator to desired setting, turn hex (F) "out" to increase pressure or "in" to reduce pressure.
7. When desired pressure setting is reached, slide sleeve (A) back to original position by aligning the crest of the hex (F) and notch of the sleeve.
8. Tighten screw (C) to lock in at desired pressure setting.

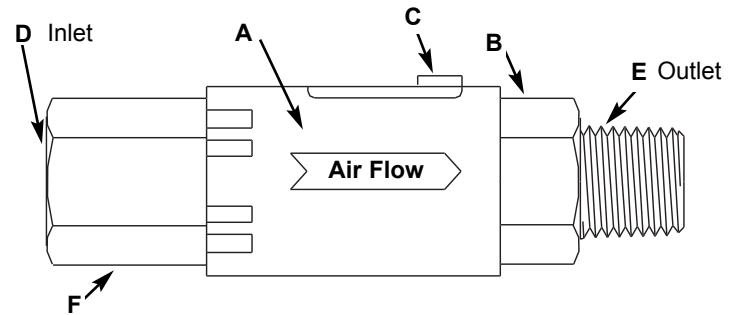

East/Central: 19 Kimberly Road • East Brunswick, NJ 08816  
Phone: 732-390-8480 / Fax: 732-390-9693

West: 1730 NE Miller Street • McMinnville, OR 97128  
Phone: 503-434-5964 / Fax: 503-472-1989

## Installation and Operation Instructions

(Use diagram at bottom of page as a guide)

1. Apply a small amount of seal compound to male threads of regulator and male threads of connector.
2. Engage regulator hex (B) with wrench and connect male outlet threads (E) to female inlet threads of tool.  
**Note: Adding a 6" snubber (whip hose) between the air tool and regulator will provide a safer and longer lasting installation.**
3. Engage regulator hex (F) with wrench and connect female inlet threads (D) to male threads of connector.
4. Engage connector to coupler of air supply line and apply pressure.
5. Loosen screw (C) and slide sleeve (A) toward tool and regulator outlet.
6. To adjust regulator to desired setting, turn hex (F) "out" to increase pressure or "in" to reduce pressure.
7. When desired pressure setting is reached, slide sleeve (A) back to original position by aligning the crest of the hex (F) and notch of the sleeve.
8. Tighten screw (C) to lock in at desired pressure setting.

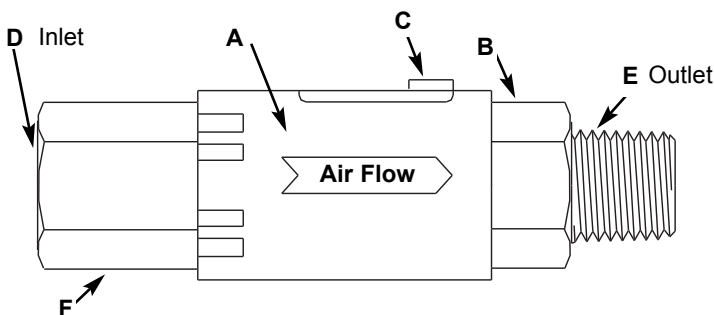

East/Central: 19 Kimberly Road • East Brunswick, NJ 08816  
Phone: 732-390-8480 / Fax: 732-390-9693

West: 1730 NE Miller Street • McMinnville, OR 97128  
Phone: 503-434-5964 / Fax: 503-472-1989

## Installation and Operation Instructions

(Use diagram at bottom of page as a guide)

1. Apply a small amount of seal compound to male threads of regulator and male threads of connector.
2. Engage regulator hex (B) with wrench and connect male outlet threads (E) to female inlet threads of tool.  
**Note: Adding a 6" snubber (whip hose) between the air tool and regulator will provide a safer and longer lasting installation.**
3. Engage regulator hex (F) with wrench and connect female inlet threads (D) to male threads of connector.
4. Engage connector to coupler of air supply line and apply pressure.
5. Loosen screw (C) and slide sleeve (A) toward tool and regulator outlet.
6. To adjust regulator to desired setting, turn hex (F) "out" to increase pressure or "in" to reduce pressure.
7. When desired pressure setting is reached, slide sleeve (A) back to original position by aligning the crest of the hex (F) and notch of the sleeve.
8. Tighten screw (C) to lock in at desired pressure setting.

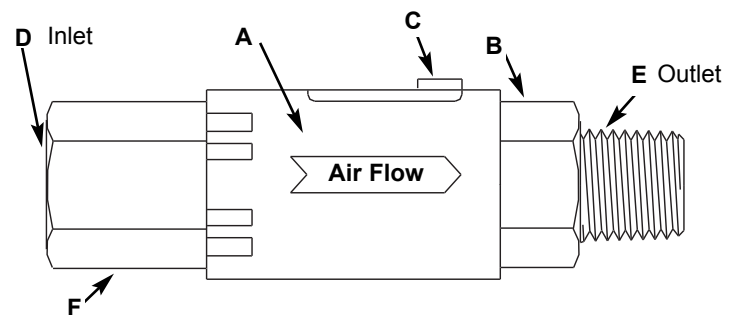

East/Central: 19 Kimberly Road • East Brunswick, NJ 08816  
Phone: 732-390-8480 / Fax: 732-390-9693

West: 1730 NE Miller Street • McMinnville, OR 97128  
Phone: 503-434-5964 / Fax: 503-472-1989