

93-420* (revised 03/09)

Questions regarding this form should be directed to one of the following:

East: 732-390-8480 (NJ)
West: 503-434-5964 (OR)
E-mail: info@coilhose.com

DESICCANT AIR DRYER Operating Instructions and Parts List

Application:

Although much of an air line's liquid condensate can be removed through the use of filters, driplegs and drain traps, water vapor and aerosols will remain in the line. The most reliable and cost efficient method of removing this residual vapor and aerosol is with a desiccant air dryer. These units are especially effective for protecting laboratory instrumentation, spray painting and air lines that are exposed to freezing conditions.

Features:

- Desiccant beads change color from blue to pink to indicate absorbing capacity (blue = dry, pink = wet).
- Provides exceptionally dry air.
- Pressure drop of less than 1 PSI.
- Easy to service.

Technical Data:

Maximum Supply Pressure:150 PSI
Maximum Operating Temperature: .125° F
Maximum Continuous Air Flow: . . .10 SCFM
Atmospheric Dew Point:-45° F

Material:

BodyDie-cast zinc
 BowlPolycarbonate
 Bowl guardSteel

Dimensions and Weights:

Height12.25"
 Width (port to port)4.5"
 Weight (with desiccant)6.8 lbs.



Ordering Information:

1/4" port8422
 3/8" port8423
 1/2" port8424
 Desiccant gel refill8422-GEL

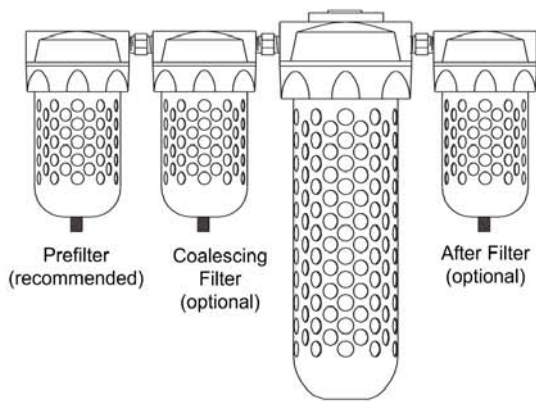

General Description of Operation:

The moist, pressurized air enters the inlet port of the desiccant dryer and is forced down through the bed of silica gel. Each silica bead is made up of many microscopic pores which attract and absorb the water vapor and aerosols as the air passes around them. As the beads become saturated, they change color from blue (dry) to pink (wet), indicating the desiccant must be replaced. With the moisture remaining trapped in the desiccant beads, the dry air passes up the center tube and through the outlet assuring a supply of moisture free air to the downstream equipment.

Installation:

The desiccant air dryer should be installed as close as possible to the area where the air is being used. To make the installation easier, do not open the package of desiccant gel and fill the bowl until the dryer is in place. Make sure the air flow is going in the same direction as the arrow at the top of the unit. Once the desiccant dryer is properly in place, the package of gel can be opened and poured into the bowl (see "Maintenance" instructions to the right for proper filling).

Although a properly installed and maintained desiccant air dryer will provide optimum results as a standalone unit, we recommend placing a particulate filter up stream from the dryer (see Figure 1). This will assure that only clean air will reach the desiccant dryer. In addition, the filter will remove some of the moisture before it reaches the dryer, thus prolonging the service life of the desiccant gel. Where there is oil or an excessive amount of moisture in the line, a coalescing filter should be installed after the particulate filter and before the desiccant dryer. Since Coilhose Pneumatics Desiccant Gel 8422-GEL produces virtually no dust, an after filter is not normally required. However, in applications where the air requirements are extremely critical, an after filter can be used to further protect the system. Recommended optional filters:

Port Size	Prefilter	Coalescing Filter	After Filter
1/4"	8822R	8922R	8822RX
3/8"	8823R	8923R	8823RX
1/2"	8824R	8924R	8824RX

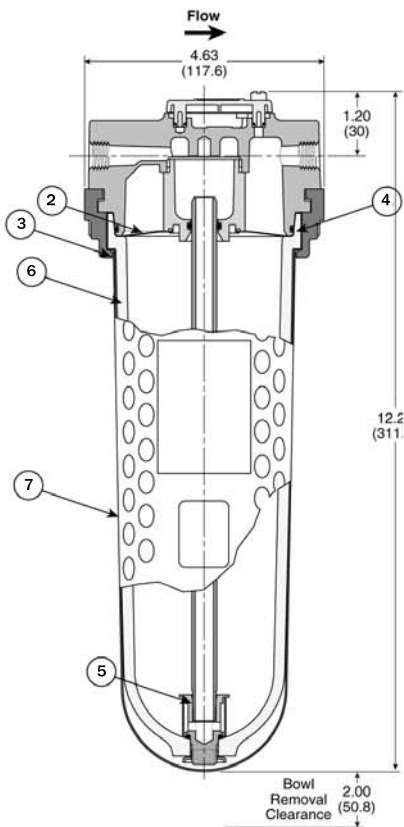

Cleaning and Maintenance:

The only maintenance required on the desiccant air dryer is when the desiccant gel turns from blue (dry) to pink (wet). This indicates that the desiccant beads are saturated and should be changed. Removal of the unit from the line is not necessary and changing the desiccant can be done without the use of any tools. The air supply must be turned off and the desiccant dryer must be depressurized prior to disassembly. Depress the locking tab on the clamping ring and, by rotating it slightly and pulling downward, the clamp is removed from the head of the desiccant dryer. This will allow the polycarbonate bowl and steel guard to come free from the top housing. Once the bowl is removed, pour out the wet (pink) desiccant gel and refill it with dry (blue) desiccant gel (Coilhose Pneumatics model number 8422-GEL) to approximately 1/8" below the inner step. Shake or tap the side of the bowl to help settle the desiccant to assure proper filling. Reassemble polycarbonate bowl, steel guard and clamping ring onto the top housing. Prior to pressurizing the unit, make sure the clamping ring is securely locked in place.

Note: Used (pink) desiccant can be regenerated as follows:

1. Pour out pink desiccant onto a flat pan.
2. Place desiccant-filled pan in 350° F oven for approximately three hours or until the desiccant changes back to blue.
3. When the desiccant returns to blue, remove it from the oven and allow to cool to room temperature.
4. Pour desiccant back into bowl, following the above instructions.

Components:

Chart No.	Description	Model No.
2	Screen assembly	8422-2
3	Clamping ring	8422-3
4	Bowl o-ring	8422-4
5	Tube assembly (with screen)	8422-5
6	Polycarbonate bowl	8422-6
7	Steel bowl guard	8422-7

We reserve the right to make engineering changes in design or materials without notification.