

Parts Manual



SAWING PRODUCTS

2013-V5

Serial No: 573-04101 to

Band Sawing Machine

MACHINE SPECIFICATIONS

MODEL SERIAL NO.

VOLTAGE CYCLE PHASE

For your information and future reference, insert pertinent data concerning your machine in the spaces provided above. This information is stamped on the data plate attached to the machine frame.

Always specify model and serial numbers on all parts orders and correspondence concerning your machine. This will help avoid unnecessary delays and inconvenience during processing.

The specifications contained herein were in effect at the time this manual was approved for printing. The DoALL Company, whose policy is one of continuous product improvement, reserves the right to change specifications or design at any time without notice and without incurring obligations.

How to read your serial number:

Example: 500-001234

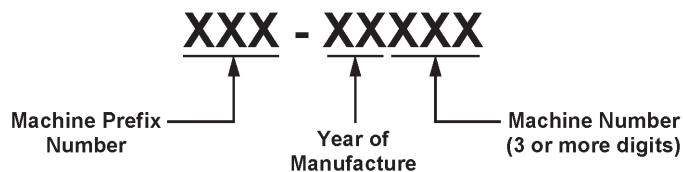

For Sales, Parts and Service, call 1-888-362-5572.



DoALL SAWING PRODUCTS
2375B TOUHY AVENUE
ELK GROVE, ILLINOIS 60007 U.S.A.

YOUR SERVICE REPRESENTATIVE:

Fiche No. C-19 Model 2013-V5 Serial No. 573-04101 to _____

PAGE NO.	DESCRIPTION	FIRST SERIAL	LAST SERIAL	PAGES
C-1-72	Final Assembly	All		2 - 3
C-9-32	*Air Feed Assembly	All		4 - 5
C-2-118	*Auxiliary Post Support Assembly (Extra Work Height)	All		6 - 7
C-7-23	*Band Filing and Polishing Assemblies	All		8 - 9
C-8-30	*Band Lubricator Assembly (Accu-Lube/Unist)	All		10 - 11
C-2-117	Bandwheel Assemblies	All		12 - 13
C-9-33	*Carrier and Cable Assembly (Air Feed)	All		14 - 15
C-9-34	*Chip Blower Assembly (And Related Items)	All		16 - 17
C-10-2	*Disc Cutter Assembly	All		18 - 19
C-1-72	Door Latches	All		2 - 3
C-5-130	Drive Assembly	All		20 - 21
C-6-35	Electrical Assembly	All		22 - 23
C-6-36	Electrical Control Box Assembly	All		24 - 25
C-2-119	*Extra Work Height Assembly	All		26 - 27
C-3-46	*Glide Table Assembly	All		28 - 29
C-10-49	*Guard Assembly (Point of Operation)	All		30 - 31
C-2-114	Head Assembly	All		32 - 33
C-1-72	Job Selector	All		2 - 3
C-6-35	Limit Switches (Interlocks)	All		24 - 25
C-10-65	*Laser Line Generator Assembly	All		34 - 35
C-8-17	*Magnifier	All		64 - 65
C-8-16	*Mist Coolant Assembly (And Related Items)	All		36 - 37
C-10-28	*Mitre Assembly (#2 Cut-Off)	All		38 - 39
C-2-115	Post Assembly	All		40 - 41
C-2-116	*Post Elevating Handwheel Assembly	All		42 - 43
C-10-42	*Protractor Work Stop & Alignment Gage Assembly	All		44 - 45
C-10-6	*Rip Fence Assembly	All		46 - 47
C-7-20	Saw Guide Assemblies (Insert/Special Application)	All		48 - 49
C-7-18	Saw Guide Assemblies (Insert Types)	All		50 - 51
C-7-19	Saw Guide Assemblies (Roller Types)	All		52 - 53
C-3-91	*Sliding Air Table Assembly	All		54 - 55
C-3-92	*Sliding Air Table Assembly (Shop Air Connection)	All		56 - 57
C-3-93	Table and Trunnion Assembly	All		58 - 59
C-3-91	*Table Cylinder (Air Table)	All		54 - 55
C-10-43	*Universally Calibrated Work Fixture Assembly	All		60 - 61
C-2-117	Wheel Hinge Assembly	All		12 - 13
C-10-16	*Work Holding Jaw Assembly	All		62 - 63
C-8-13	*Worklamp Assembly	All		64 - 65
	*Denotes Attachment or Optional Equipment.			

NEW DRG.
S.C.L. 2-25-04
REVISIONS
S.C.L. 8-16-06
S.C.L. 2-14-08
S.C.L. 8-3-09

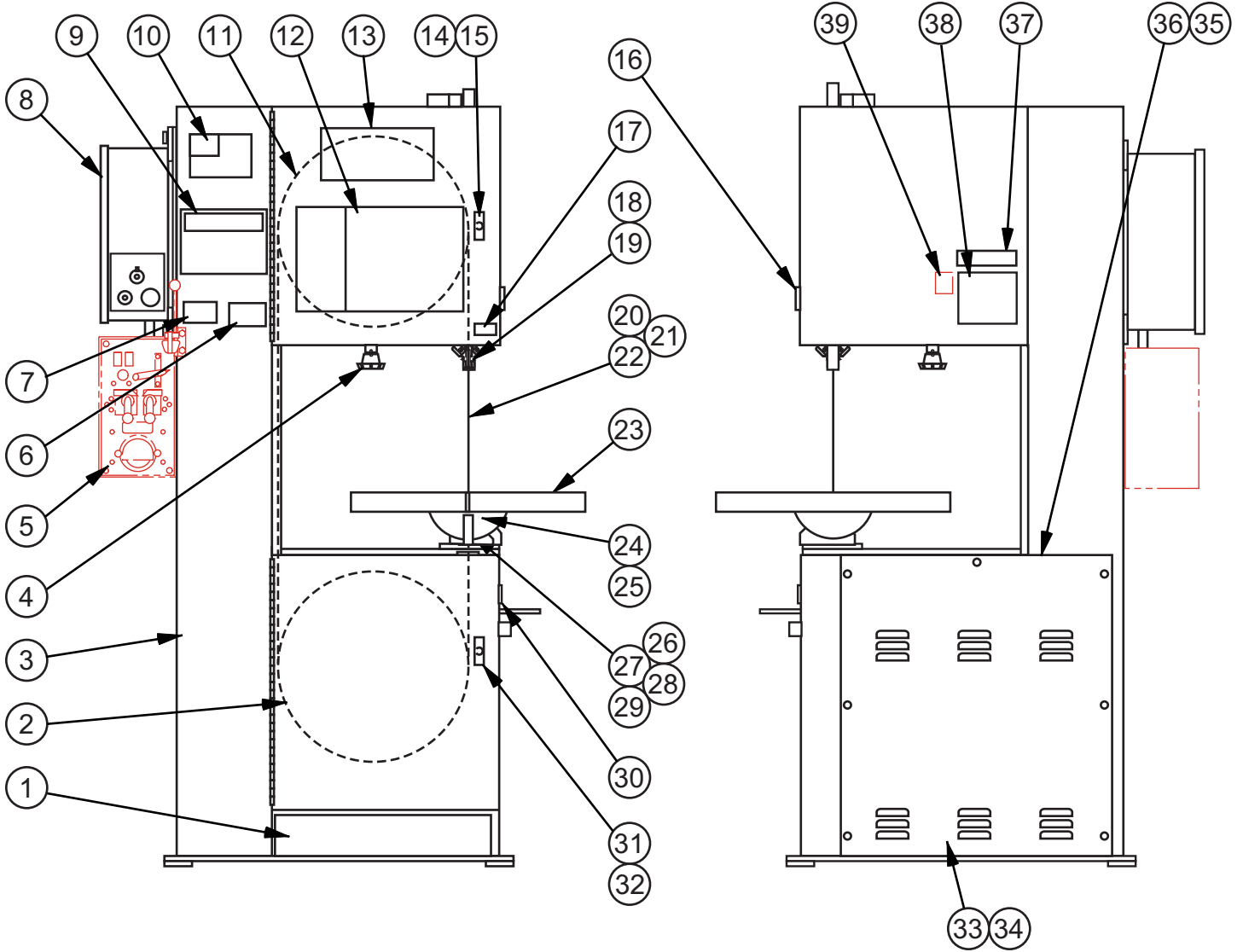

MODEL FIRST MACH. LAST MACH.
 2013-V3 572-04101
 2013-V5 573-04101

FINAL ASSEMBLY

FINAL ASSEMBLY

INDEX NO.	PART NO.	DESCRIPTION	UNITS PER ASS'Y.
Ref.	290184	Final Assembly (2013-V3)	
Ref.	290207	Final Assembly (2013-V5)	
1	404522	. Chip Box Weldment (Standard)	1
	414621	. Chip Box Assembly (Dust Spout Option)	1
2		. Drive Assembly (See Detail)	1
3*	220211	. Frame Weldment	1
4	009400	. Knob Assembly	1
5		. DBW-15 Butt welder Assembly (Optional) (See Welder Manual)	1
6	209652	. Escutcheon (Diameters/X-Section Areas)	1
7	145882	. Escutcheon (Caution) (English)	1
	149667	. Escutcheon (Caution) (International)	1
8		. Electrical Assembly (See Detail)	1
9	404476	. Escutcheon (Warning)	1
10	201469	. Decal (American Flag)	1
11	520279	. Head Assembly (See Detail)	1
12	515907	. Job Selector	1
13	416163	. Decal (DoALL)	1
14	172762	. Latch	1
15	198853	. Screw, Rd. Hd. Mach. #8-32NC x 3/8	2
16	216862	. Plastic Cover	1
17	131033	. Escutcheon (Warning) (English)	1
	131408	. Escutcheon (Warning) (International)	1
18	028081	. Upper Saw Guide Assembly (See Detail)	1
19	018500	. Upper Saw Guide Holding Screw	2
20*	171508	. Saw Band (Imperial Bi-Metal Super Silencer)	1
21	304525	. Saw Band Tag	1
22	222563	. Tag (Installation Instructions)	1
23		. Table and Trunnion Assembly (See Detail)	1
24	028082	. Lower Saw Guide Assembly (See Detail)	1
25	198246	. Screw, Soc. Hd. Cap 1/4-20NC x 1-3/4	2
26	413965	. Guard Weldment (Standard)	1
	414435	. Guard Weldment (Air Table and/or Rip Fence Options)	1
	417086	. Guard Assembly (Point of Operation) (Optional) (See Detail)	1
27	198867	. Screw, Rd. Hd. Mach. #10-24NC x 3/8	2
28	199111	. Nut, Hex. #10-24NC	2
29	199320	. Washer, Lock #10 Std.	2
30	172654	. Escutcheon (Caution) (English) (2013-V3 Only)	1
	172655	. Escutcheon (Caution) (International) (2013-V3 Only)	1
31	172762	. Latch	1
32	198853	. Screw, Rd. Hd. Mach. #8-32NC x 3/8	2
33	420945	. Rear Drive Cover	1
34	199299	. Screw, Hex. Hd. Self-Drill M4.8 x 13	7
35	420725	. Top Drive Cover	1
36	199299	. Screw, Hex. Hd. Self-Drill M4.8 x 13	6
37	222562	. Label (1-888-DoALL)	1
38	1012541	. Label (Machine Specifications)	1
39	206698	. CE Label (Europa Only)	1

*NOTE: See Extra Work Height Assembly If Applicable.

Following Not Shown:

128854	. Escutcheon (Government Specifications)	1
199397	. Screw, Rd. Hd. Drive #2 x 1/4	4
406871	. Instruction Tag	1
222564	. Box of Extra Parts	1
222559	. Saw Guide Insert Pack (See Detail)	1
010853	. Wrench (Table Tilt)	1
199568	. Hex. Key 3/16"	1
207664	. Documentation CD (2013-V3)	1
207665	. Documentation CD (2013-V5)	1
1013223	. Pallet	1
123001	. Shipping Bracket and Hardware (Export Only)	1
417228	. Shipping Container (Government)	1

NEW DRG.
S.C.L. 2-25-04
REVISIONS
S.C.L. 2-11-08
S.C.L. 8-3-09
S.C.L. 8-25-11
S.C.L. 7-8-13

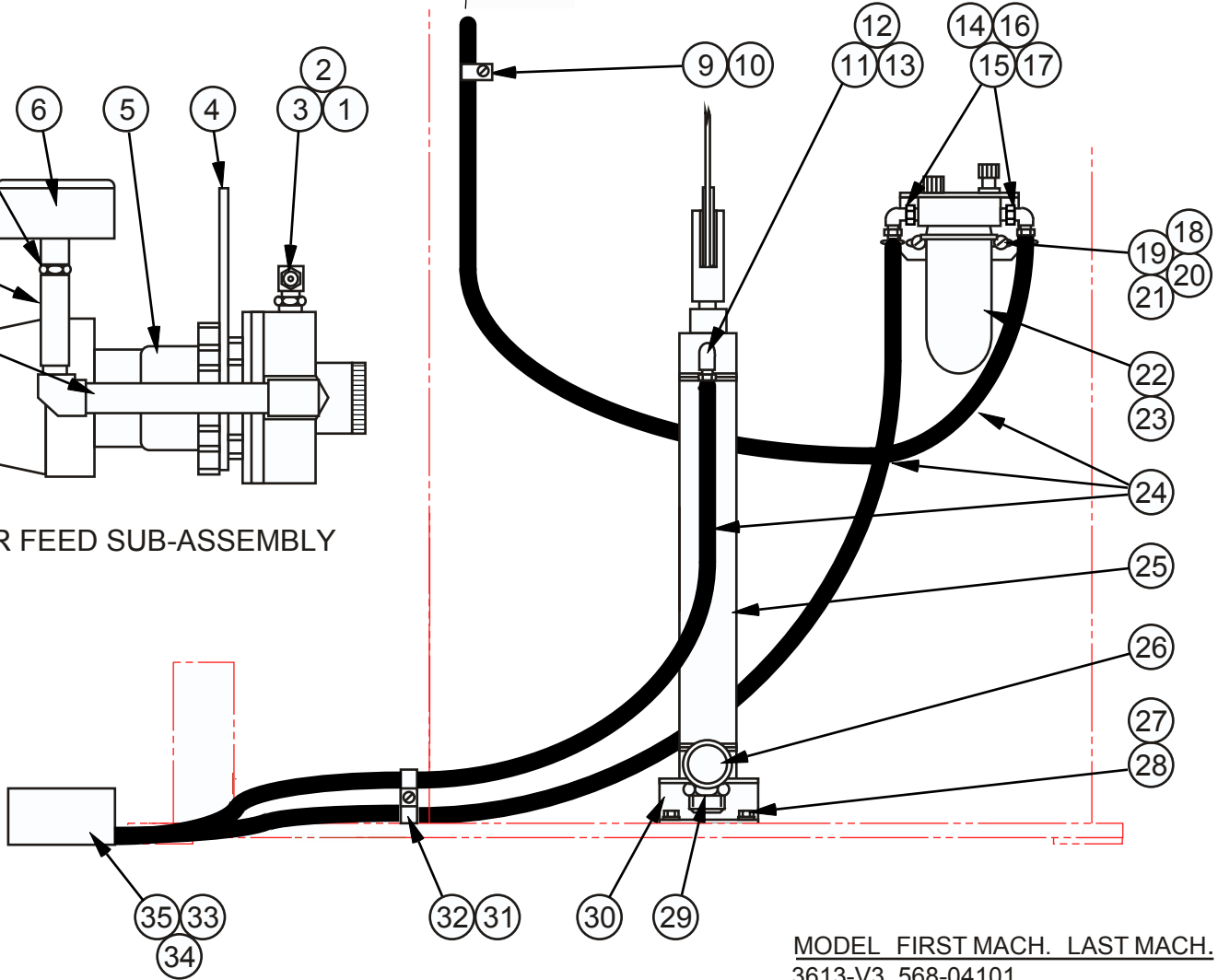
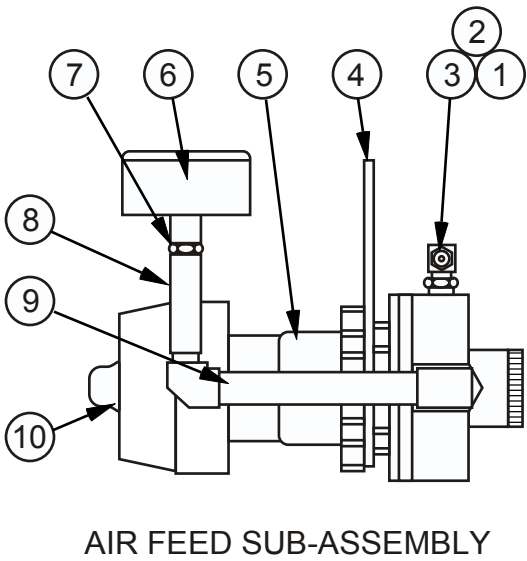
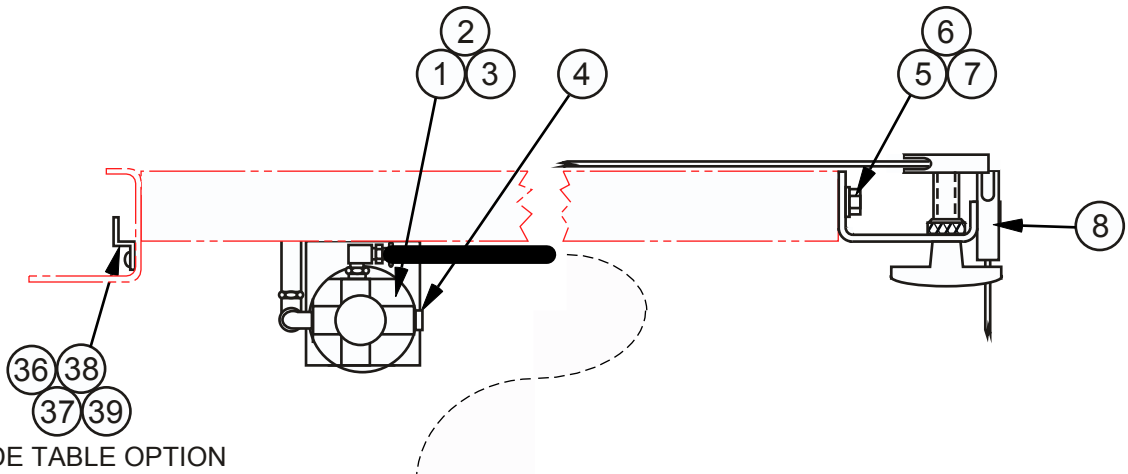

MODEL	FIRST MACH.	LAST MACH.
3613-V3	568-04101	
3613-V5	569-04101	
2013-V	571-04101	
2013-V3	572-04101	
2013-V5	573-04101	
3613-1	577-04101	
2613-V3	589-09101	

AIR FEED ASSEMBLY

AIR FEED ASSEMBLY

INDEX NO.	PART NO.	DESCRIPTION	UNITS PER ASSY.
Ref.	513087	Air Feed Assembly	
Ref.	517986	Air Feed Assembly (With Glide Table Option) (20" Machines)	
Ref.	221718	Air Feed Assembly (With Glide Table Option) (36" Machines)	
1	416813	. Air Feed Sub-Assembly (See Detail)	1
2	198008	. Screw, Hex. Hd. Cap 1/4-20NC x 3/4	2
3	199321	. Washer, Lock 1/4 Std.	2
4	203604	. Pipe Plug (Brass) (If Supplied)	1
5	198044	. Screw, Hex. Hd. Cap 3/8-16NC x 3/4	3
6	199325	. Washer, Lock 3/8 Std.	3
7	34-005414	. Spacer Washer	3
8	420866	. Carrier and Cable Assembly (Air Feed) (See Detail)	1
9	115652	. Tubing Clamp	1
10	199484	. Screw, Pan Hd. Self-Tap 1/4-20NC x 1/2	1
11	008254	. 90° Street Elbow (Brass)	1
12	002004	. Barbed Insert	1
13	35-006888	. Hose Clamp	2
14	203221	. Reducer Bushing (Brass)	2
15	008254	. 90° Street Elbow (Brass)	2
16	002004	. Barbed Insert	2
17	35-006888	. Hose Clamp	2
18	198896	. Screw, Rd. Hd. Mach. 1/4-20NC x 5/8	2
19	199374	. Washer, Lock 1/4 Shakeproof Ext.	2
20	199260	. Washer, Flat 1/4 S.A.E. Std.	2
21	199115	. Nut, Hex. 1/4-20NC	2
22	145883	. Oil-Fog Lubricator (Includes Bracket)	1
23	138445	. Oil (ASTM 315)	A.R.
24	197094	. Neoprene Hose 11/16 O.D. (Black)	A.R.
25	172794	. Air Cylinder	1
26	169631	. Air Filter	1
27	198006	. Screw, Hex. Hd. Cap 1/4-20NC x 1/2 (20" Machines)	4
	198045	. Screw, Hex. Hd. Cap 3/8-16NC x 7/8 (36" Machines)	4
28	199321	. Washer, Lock 1/4 Std. (20" Machines)	4
	199325	. Washer, Lock 3/8 Std. (36" Machines)	4
29	199147	. Nut, Hex. Jam 1-14NF	1
30	325663	. Cylinder Mounting Bracket (20" Machines)	1
	326102	. Cylinder Mounting Bracket (36" Machines)	1
31	115652	. Tubing Clamp	2
32	199484	. Screw, Pan Hd. Self-Tap 1/4-20NC x 1/2	1
33	172793	. Foot Valve	1
34	172792	. Guard	1
35	128179	. Barbed Insert	2
For Machines with Glide Table Option:			
36	209139	. Chain Support (13")	3
37	209140	. Chain Support (2")	1
38	199649	. Screw, Button Hd. Soc. #10-24NC x 1/4	8
39	199320	. Washer, Lock #10 Std.	8
Following Not Shown:			
	5-013007	. Work Holding Jaw Assembly (See Detail)	1
Ref.	416813	. Air Feed Sub-Assembly	
1	203219	. Reducer Bushing (Brass)	1
2	5-027506	. 90° Street Elbow (Brass)	1
3	128179	. Barbed Insert	1
4	315365	. Bracket	1
5	125674	. Regulating Valve	1
6	35-009530	. Gauge	1
7	203219	. Reducer Bushing (Brass)	1
8	204233	. Pipe Coupling (Brass)	1
9	203482	. Pipe Nipple (4") (Brass)	1
10	008254	. 90° Street Elbow (Brass)	2

NEW DRG.
S.C.L. 2-25-04
REVISIONS
S.C.L. 4-4-07
S.C.L. 2-11-08
S.C.L. 9-9-09

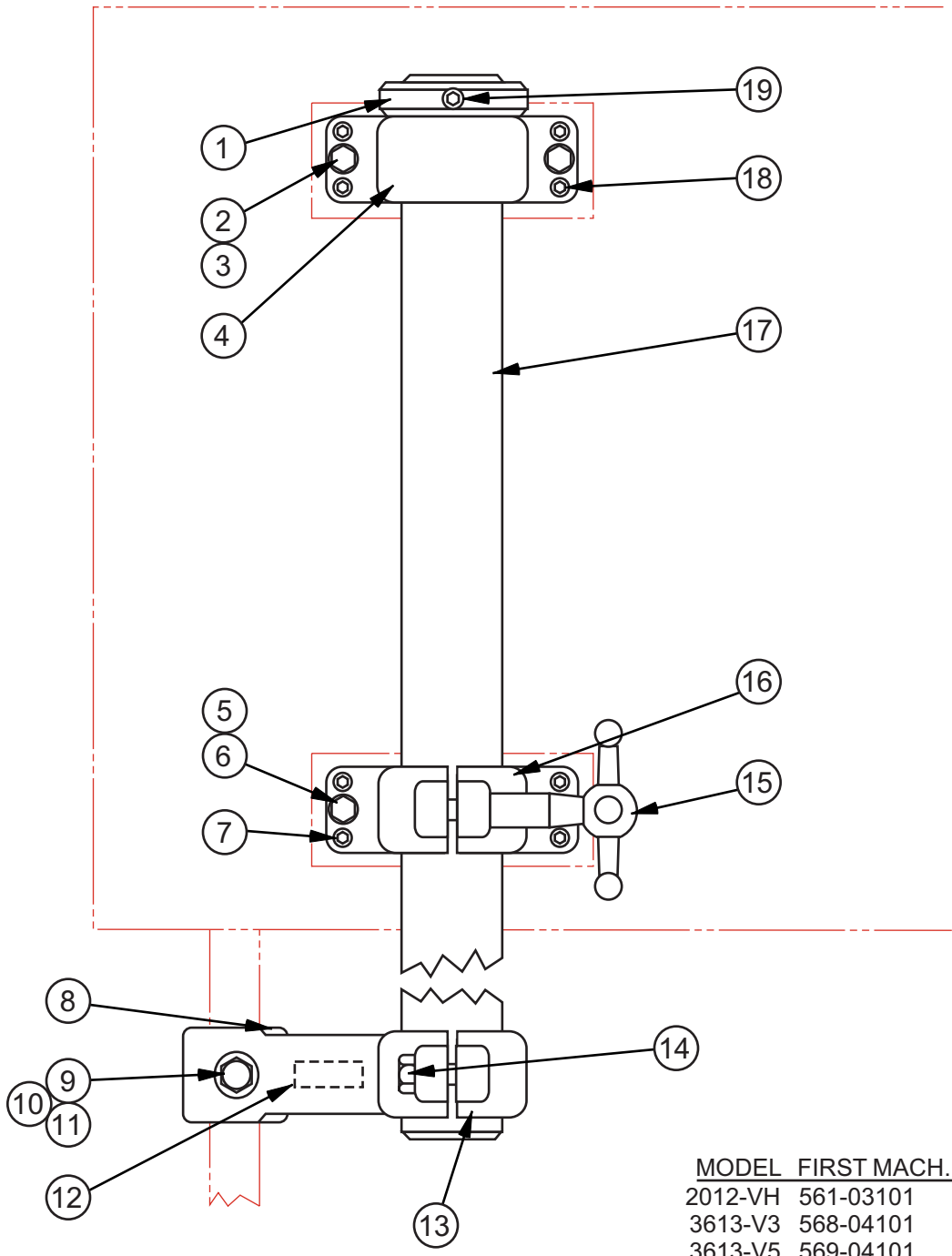

MODEL	FIRST MACH.	LAST MACH.
2012-VH	561-03101	
3613-V3	568-04101	
3613-V5	569-04101	
3612-VH	570-04101	
2013-V	571-04101	
2013-V3	572-04101	
2013-V5	573-04101	
3613-1	577-04101	
2012-D12	584-08101	
2613-V3	589-09101	

AUXILIARY POST SUPPORT ASSEMBLY (EXTRA WORK HEIGHT)

C - 2 - 118 CM - 2 - 132

PRINTED IN U.S.A.

AUXILIARY POST SUPPORT ASSEMBLY

INDEX NO.	PART NO.	DESCRIPTION	UNITS PER ASS'Y.
Ref.	506149	Auxiliary Post Support Assembly	
1	13-001423	. Post Collar	1
2	198048	. Screw, Hex. Hd. Cap 3/8-16NC x 1-1/2	2
3	199325	. Washer, Lock 3/8 Std.	2
4	032463	. Upper Post Guide	1
5	198048	. Screw, Hex. Hd. Cap 3/8-16NC x 1-1/2	2
6	199325	. Washer, Lock 3/8 Std.	2
7	198439	. Screw, Soc. Set 5/16-18NC x 3/4	4
8	13-001309	. Back-Up Pad	1
9	13-001419	. Back-Up Pad Screw 1/2-13NC x 4-1/8	1
10	199132	. Nut, Hex. Jam 1/2-13NC	1
11	35-009616	. Retaining Ring	1
12	203551	. Escutcheon (Remove Bracket)	1
13	024337	. Support Arm	1
14	198067	. Screw, Hex. Hd. Cap 1/2-13NC x 1-1/2	1
15	007629	. Starwheel Assembly	1
	6-001103	. . Starwheel	1
	004261	. . Spring Pin	1
	13-001422	. . Post Clamp Screw	1
16	032462	. Lower Post Guide	1
17	305659	. Auxiliary Post (24" Work Height)	1
	305660	. Auxiliary Post (30" Work Height)	1
18	198439	. Screw, Soc. Set 5/16-18NC x 3/4	4
19	198450	. Screw, Soc. Set 3/8-16NC x 5/8	1

NEW DRG.
S.C.L. 9-25-97
REVISIONS
S.C.L. 6-28-01
S.C.L. 2-20-04
S.C.L. 2-11-08

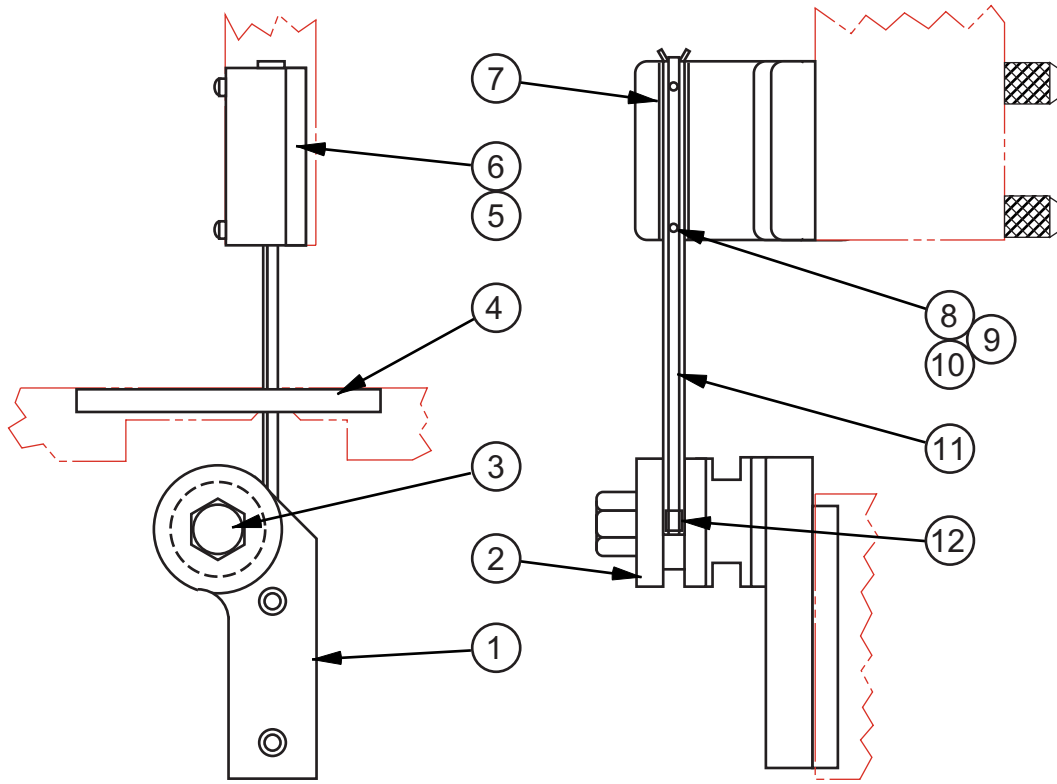

BAND FILING ASSEMBLY

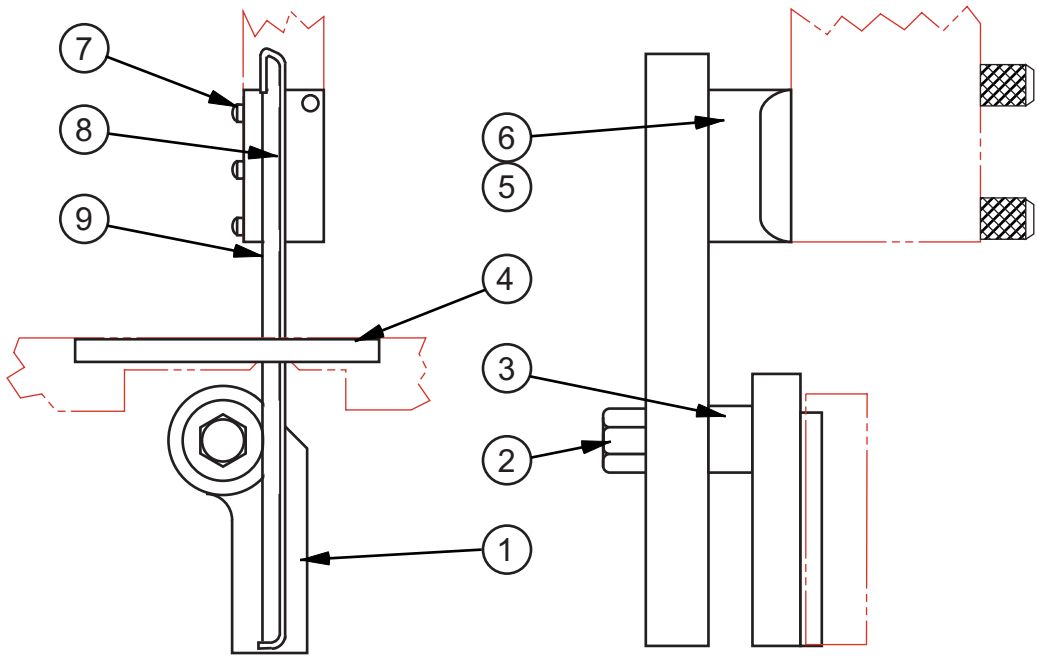

BAND POLISHING ASSEMBLY

**BAND FILING ASSEMBLY
BAND POLISHING ASSEMBLY**

BAND FILING ASSEMBLY
BAND POLISHING ASSEMBLY

INDEX NO.	PART NO.	DESCRIPTION	UNITS PER ASS'Y.
Ref.	044780	Band Filing Assembly (Short Guides, 26" Table)	
Ref.	111948	Band Filing Assembly (Long Guides, 26" Table)	
Ref.	404994	Band Filing Assembly (Short Guides, 30" Table)	
Ref.	132773	Band Filing Assembly (Long Guides, 30" Table)	
1	001371	. Adaptor	1
2	34-009312	. File Guide Back-Up	1
3	34-009001	. File Guide Back-Up Screw	1
4	317592	. Center Plate (Oval) (26" Table)	1
	010627	. Center Plate (Round) (26" Table)	1
	120128	. Center Plate (Round) (30" Table)	1
5	027487	. 1/4" File Guide Assembly (Short Guides)	1
	027490	. 1/4" File Guide Assembly (Long Guides)	1
	027488	. 3/8" File Guide Assembly (Short Guides)	1
	027491	. 3/8" File Guide Assembly (Long Guides)	1
	027489	. 1/2" File Guide Assembly (Short Guides)	1
	027492	. 1/2" File Guide Assembly (Long Guides)	1
6	027417	. . Bracket (1/4", Short Guides)	1
	027418	. . Bracket (1/4", Long Guides)	1
	027420	. . Bracket (3/8", Short Guides)	1
	027421	. . Bracket (3/8", Long Guides)	1
	027419	. . Bracket (1/2", Short Guides)	1
	027422	. . Bracket (1/2", Long Guides)	1
7	6-009307	. . Insert (1/4", Short Guides)	1
	6-009303	. . Insert (1/4", Long Guides)	1
	6-009301	. . Insert (3/8", Short Guides)	1
	6-009305	. . Insert (3/8", Long Guides)	1
	6-009309	. . Insert (1/2", Short Guides)	1
	6-009311	. . Insert (1/2", Long Guides)	1
8	198922	. . Screw, Rd. Hd. Mach. #4-40NC x 5/8 (1/4" File Guides)	2
	198699	. . Screw, Fill. Hd. Mach. #10-24NC x 5/8 (3/8" & 1/2" File Guides)	2
9	199315	. . Washer, Lock #4 Std. (1/4" File Guides)	2
	199319	. . Washer, Lock #10 Std. (3/8" & 1/2" File Guides)	2
10	6-009314	. . Washer (1/4" File Guides) (Between File Guide & Insert)	2
	6-009313	. . Washer (3/8" & 1/2" File Guides) (Between File Guide & Insert)	2
11	6-009308	. . File Guide (1/4", Short Guides)	1
	6-009304	. . File Guide (1/4", Long Guides)	1
	6-009302	. . File Guide (3/8", Short Guides)	1
	6-009306	. . File Guide (3/8", Long Guides)	1
	6-009310	. . File Guide (1/2", Short Guides)	1
	6-009312	. . File Guide (1/2", Long Guides)	1
12	34-009313	. . Guide Plate (1/4", Long Guides Only)	2
13	34-009402	. . Pin (1/4", Long Guides Only)	2
Ref.	201220	Band Polishing Assembly (26" Table)	
Ref.	106957	Band Polishing Assembly (30" Table)	
1	001371	. Adaptor	1
2	34-009001	. Back-Up Screw	1
3	34-010402	. Guide Back-Up	1
4*	318034	. Center Plate (Oval) (26" Table) (Not Shown)	1
	010570	. Center Plate (Round) (30" Table) (Not Shown)	1
5	016686	. Band Polishing Sub-Assembly	1
6	027412	. . Bracket	1
7	198696	. . Screw, Fill. Hd. Mach. #10-24NC x 3/8	3
8	34-010504	. . Back-Up Cloth	1
	136889	. . Adhesive	A.R.
9	6-010301	. . Back-Up Plate	1

*NOTE: Some 26" Tables will have the Round Center Plate Used on 30" Tables.

NEW DRG.
S.C.L. 5-1-00
REVISIONS
S.C.L. 2-25-04
S.C.L. 8-16-06
S.C.L. 2-8-08

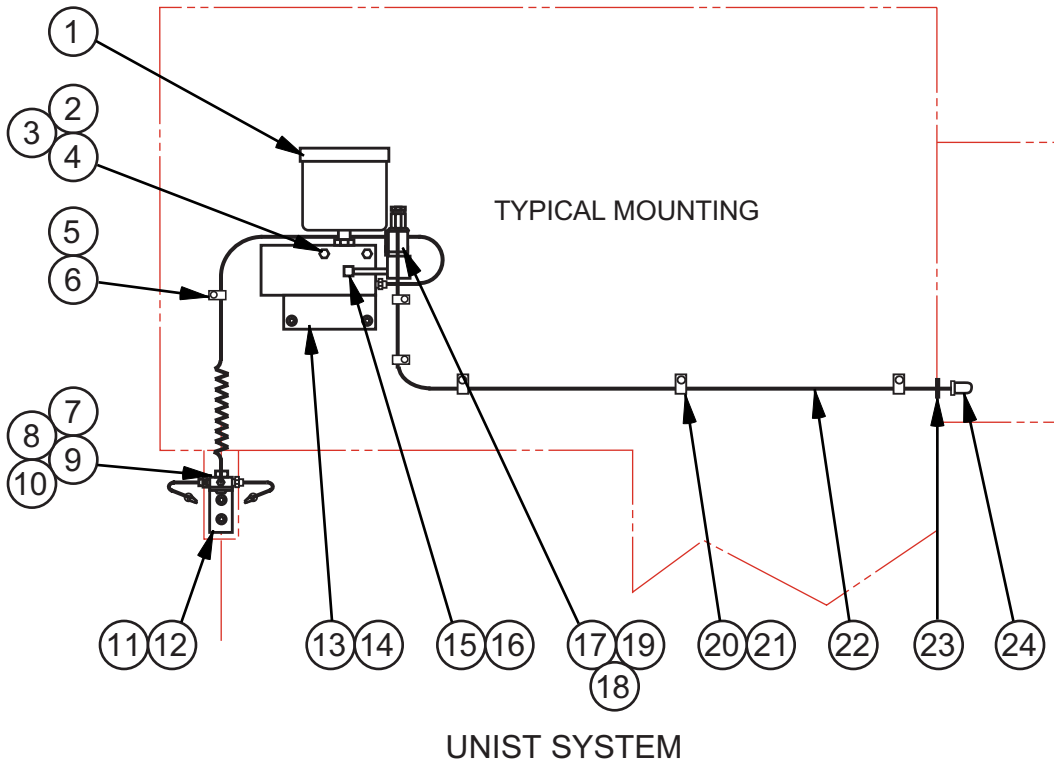
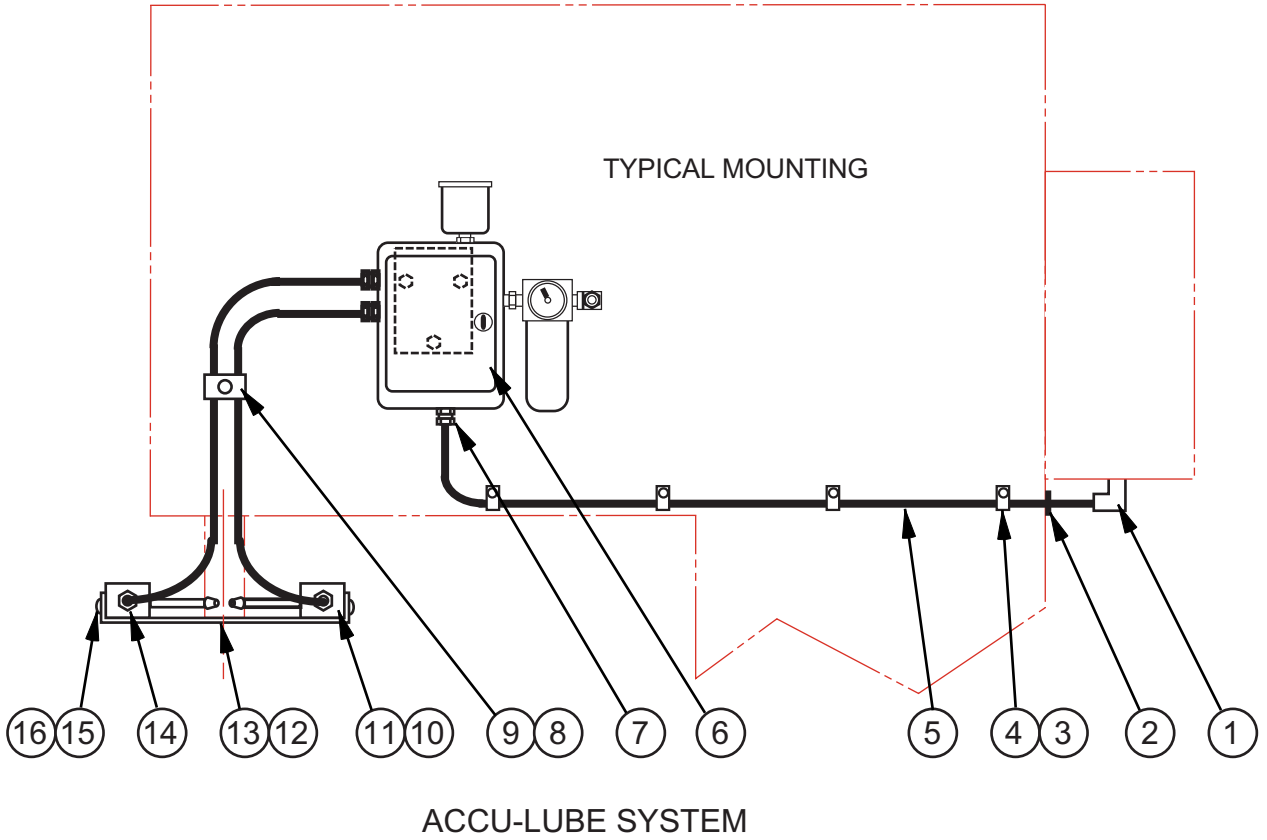

BAND LUBRICATOR ASSEMBLY

C - 8 - 30 CM - 8 - 52 Z - 8 - 26

PRINTED IN U.S.A.

BAND LUBRICATOR ASSEMBLY

INDEX NO.	PART NO.	DESCRIPTION	UNITS PER ASS'Y.
Ref.	520296	Band Lubricator Assembly (Accu-Lube System)	
1	320570	. 90° Cord Grip Connector (.125-.375)	1
2	133195	. Grommet	1
3	009955	. Tubing Clamp	4
4	199484	. Screw, Rd. Hd. Self-Tap 1/4-20NC x 1/2	4
5	197332	. Electrical Cord (#18-2 Conductor)	A.R.
6	204206	. Applicator Unit (Includes Hoses, Nozzles, etc.)	1
7	015139	. Cord Grip Connector (.250-.375)	1
8	313336	. Double Support	1
9	198276	. Screw, Soc. Hd. Cap 3/8-16NC x 1/2	1
10	216855	. Block	2
11	309004	. Male Connector	2
12	324404	. Mounting Bracket	1
13	198353	. Screw, Flat Hd. Soc. #6-32NC x 3/8	2
14	016001	. Barbed Insert	2
15	198207	. Screw, Soc. Hd. Cap #6-32NC x 3/8	4
16	199256	. Washer, Flat #6 S.A.E. Std.	4

Following Not Shown and Mounted on or Near the Control Box:

211111	. Selector Switch (2 Position)	1
217373	. Escutcheon (Mist Lube)	1

Ref.	1002498	Band Lubricator Assembly (Unist System)	
1	217359	. Applicator Unit (Includes Hose)	1
2	198015	. Screw, Hex. Hd. Cap 1/4-20NC x 2-1/4	2
3	199115	. Nut, Hex. 1/4-20NC	2
4	199321	. Washer, Lock 1/4 Std.	2
5	209458	. Hose Clamp (Half)	1
6	198321	. Screw, Button Hd. Soc. #10-24NC x 3/8	1
7	215821	. Nozzle Splitter	1
8	198360	. Screw, Button Hd. Soc. 1/4-20NC x 7/8	1
9	199114	. Nut, Hex. Jam 1/4-20NC	1
10	199321	. Washer, Lock 1/4 Std.	1
11	215917	. Mounting Bracket	1
12	198366	. Screw, Button Hd. Soc. 1/4-20NC x 3/8	2
13	214906	. Mounting Bracket	1
14	198366	. Screw, Button Hd. Soc. 1/4-20NC x 3/8	2
15	5-027506	. 90° Street Elbow	1
16	203144	. Pipe Nipple (Brass)	1
17	176829	. Solenoid Valve (3-Way)	1
18	177054	. Solenoid Plug Connector Kit	1
19	176811	. Vent Filter Breather	1
20	009955	. Tubing Clamp	5
21	198366	. Screw, Button Hd. Soc. 1/4-20NC x 3/8	5
22	197344	. Electrical Cord (#18-3 Conductor)	A.R.
23	133195	. Grommet (If Supplied)	1
24	201688	. Cord Grip Connector (.200-.394)	1

Following Not Shown and Mounted on or Near the Control Box on Selected Models:

211111	. Selector Switch (2 Position) (Includes Contact Blocks)	1
217373	. Escutcheon (Mist Lube)	1

NEW DRG.
S.C.L. 2-25-04
REVISIONS
S.C.L. 4-4-07
S.C.L. 2-11-08

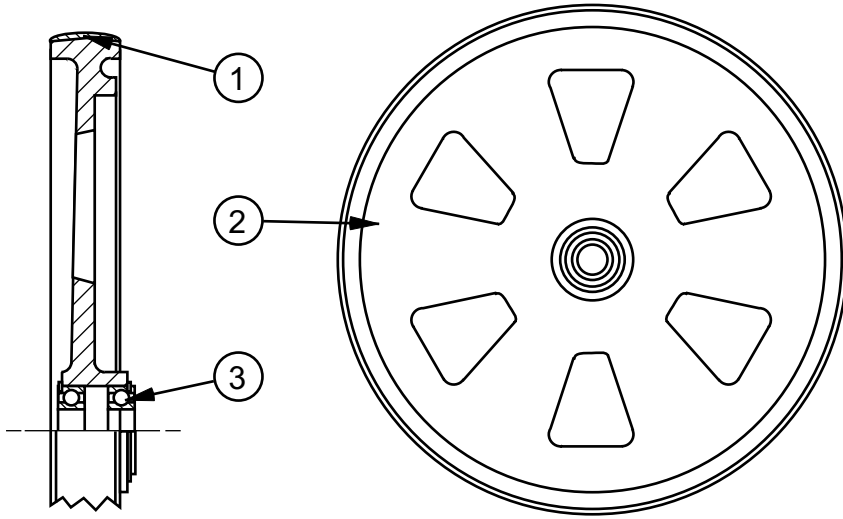

CROWNED BANDWHEELS

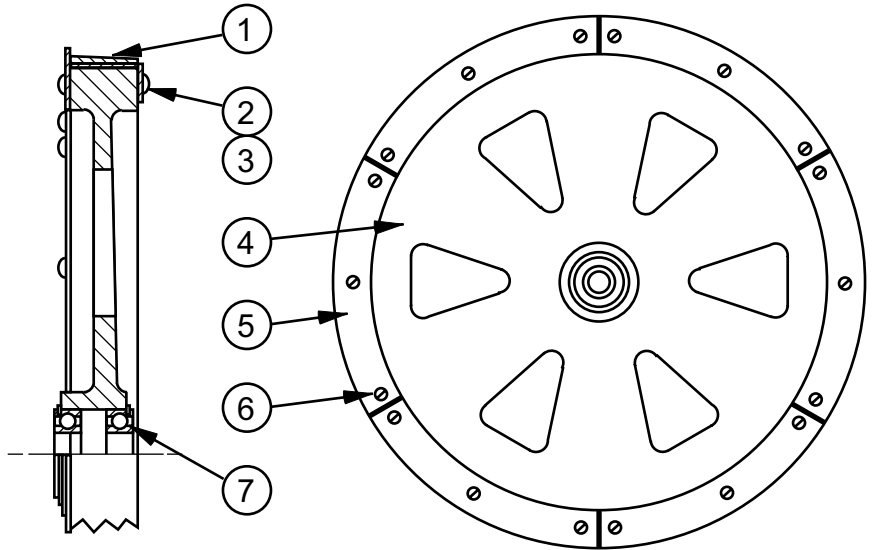

FLANGED BANDWHEELS

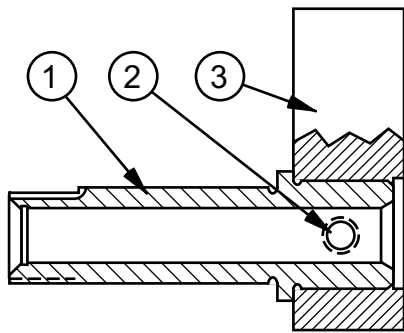

WHEEL HINGE ASSEMBLY

MODEL	FIRST MACH.	LAST MACH.
2012-VH	561-03101	
3613-V3	568-04101	
3613-V5	569-04101	
3612-VH	570-04101	
2013-V	571-04101	
2013-V3	572-04101	
2013-V5	573-04101	
3613-1	577-04101	
2012-D12	584-08101	

BANDWHEEL ASSEMBLIES

BANDWHEEL ASSEMBLIES

INDEX NO.	PART NO.	DESCRIPTION	UNITS PER ASS'Y.
<u>CROWNED BANDWHEELS</u>			
Ref.	402598	Bandwheel Assembly (Upper and Idler)	
Ref.	039712	Bandwheel Assembly (Lower)	
1	125357	. Tire	1
2	402597	. Bandwheel (Upper and Idler)	1
	402599	. Bandwheel (Lower)	1
3	5-001508	. Ball Bearing (Upper and Idler Bandwheels Only)	2
<u>FLANGED BANDWHEELS</u>			
Ref.	406558	Bandwheel Assembly (Upper and Idler)	
Ref.	408945	Bandwheel Assembly (Lower)	
1	305030	. Tire And Rim Assembly	1
2	004675	. Retainer	4
3	198000	. Screw, Hex. Hd. Cap #10-24NC x 3/8	8
4	406458	. Bandwheel (Upper and Idler)	1
	408875	. Bandwheel (Lower)	1
5	304732	. Flange Segment	6
6	198000	. Screw, Hex. Hd. Cap #10-24NC x 3/8	18
7	5-001508	. Ball Bearing (Upper and Idler Bandwheels Only)	2
Ref.	302346	Wheel Hinge Assembly	
1	5-001424	. Axis Stud	1
2	198423	. Screw, Soc. Set 1/4-20NC x 5/16	1
3	120624	. Block	1

NEW DRG.
S.C.L. 2-25-04
REVISIONS
S.C.L. 2-11-08

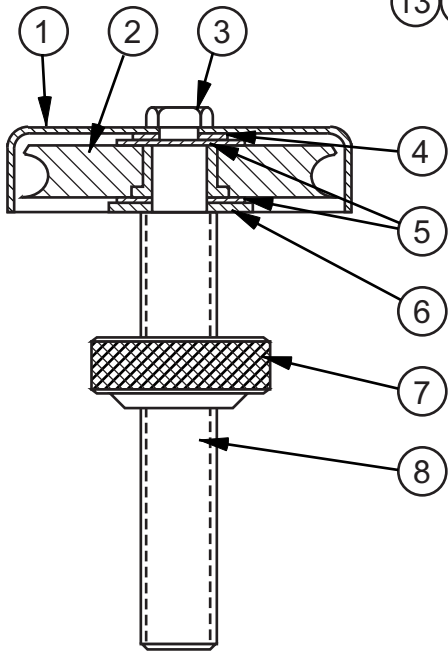
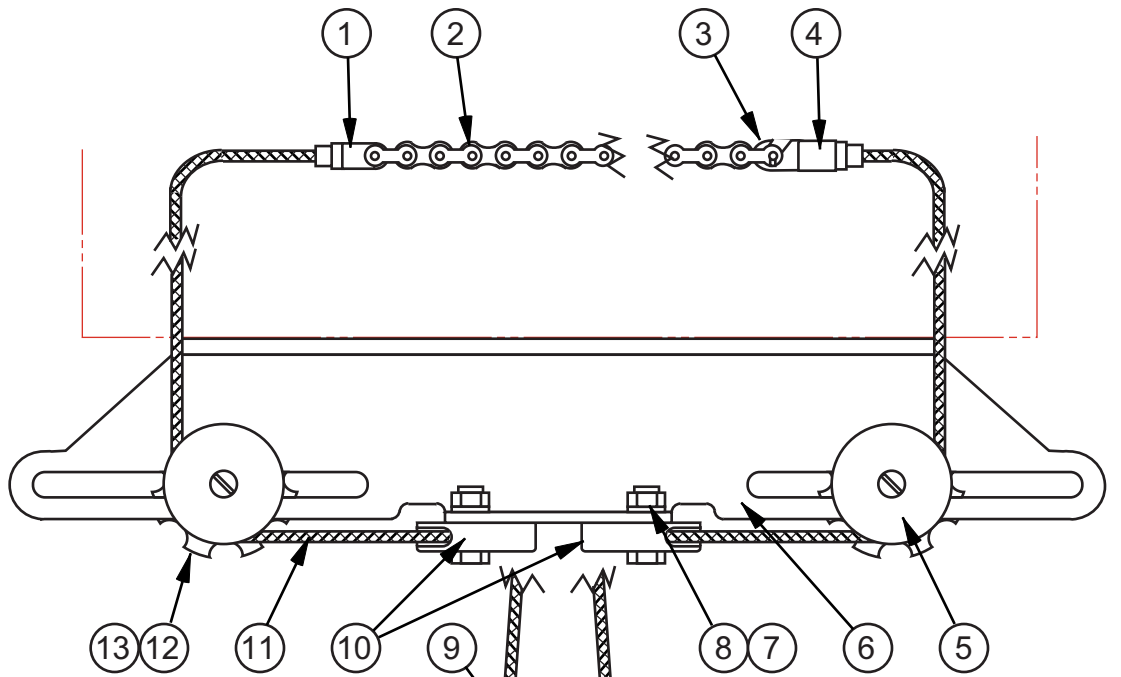

HORIZONTAL PULLEY ASSEMBLY

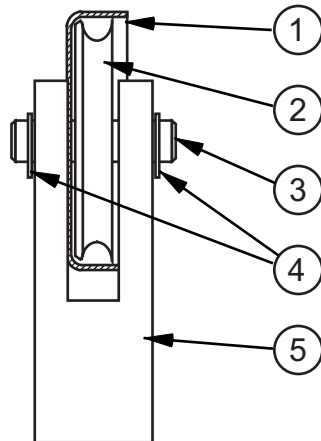

EQUALIZER PULLEY ASSEMBLY

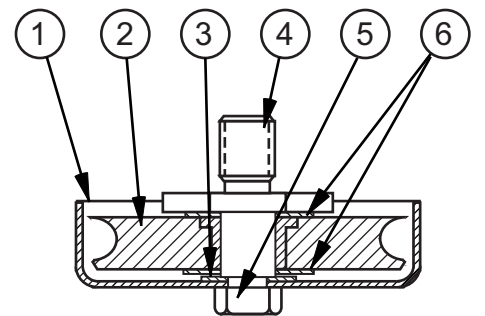

VERTICAL PULLEY ASSEMBLY

MODEL	FIRST MACH.	LAST MACH.
3613-V3	568-04101	
3613-V5	569-04101	
2013-V	571-04101	
2013-V3	572-04101	
2013-V5	573-04101	
3613-1	577-04101	

CARRIER AND CABLE ASSEMBLY (AIR FEED)

CARRIER and CABLE ASSEMBLY
(Air Feed)

INDEX NO.	PART NO.	DESCRIPTION	UNITS PER ASS'Y.
Ref.	420866	Carrier and Cable Assembly	
1	5-013417	. Cable Clamp Housing	1
2	35-005011	. Power Feed Chain Assembly	1
	6-013501	.. Power Feed Chain	1
	5-013419	.. Cable Clamp Eye	1
	199546	.. Rivet (3/16 x 7/16)	1
3	5-013418	. Cable Clamp Hook	1
4	5-013417	. Cable Clamp Housing	1
5	35-006395	. Horizontal Pulley Assembly (See Detail)	2
6	521571	. Cable Carrier	1
7	199127	. Nut, Hex. Jam 3/8-16NC	2
8	199325	. Washer, Lock 3/8 Std.	2
9	315362	. Equalizer Pulley Assembly (See Detail)	1
10	35-006396	. Vertical Pulley Assembly (See Detail)	2
11	35-005288	. Power Feed Cord	1
12	34-013106	. Handwheel	2
13	199266	. Washer, Flat 1/2 S.A.E. Std.	2
Ref.	35-006395	. Horizontal Pulley Assembly	
1	34-013301	.. Cap	1
2	204986	.. Pulley	1
3	198005	.. Screw, Hex. Hd. Cap 1/4-20NC x 3/8	1
4	199376	.. Washer, Lock 1/4 Shakeproof	1
5	5-013309	.. Pulley Spacer	2
6	199302	.. Washer, Flat 3/8 Wrought	1
7	34-013418	.. Thumb Nut	1
8	35-006398	.. Pulley Screw	1
Ref.	315362	. Equalizer Pulley Assembly	
1	34-013311	.. Cap	1
2	204986	.. Pulley	1
3	003275	.. Pulley Axis	1
4	003276	.. Retaining Ring	2
5	172795	.. Clevis	1
Ref.	35-006396	. Vertical Pulley Assembly	
1	34-013301	.. Cap	1
2	204986	.. Pulley	1
3	199374	.. Washer, Lock 1/4 Shakeproof.	1
4	204985	.. Pulley Stud	1
5	198005	.. Screw, Hex. Hd. Cap 1/4-20NC x 3/8	1
6	5-013309	.. Pulley Spacer	2

NEW DRG. S.C.L. 2-25-04
REVISIONS
S.C.L. 8-16-06
S.C.L. 9-11-07
S.C.L. 2-11-08
S.C.L. 8-3-09

SEE AIR TABLE ASSEMBLY
(SHOP AIR CONNECTION)
FOR MORE PARTS

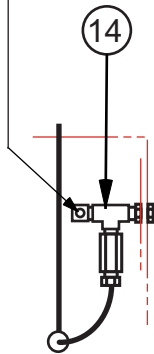

WHEN AIR TABLE IS
ALSO SUPPLIED

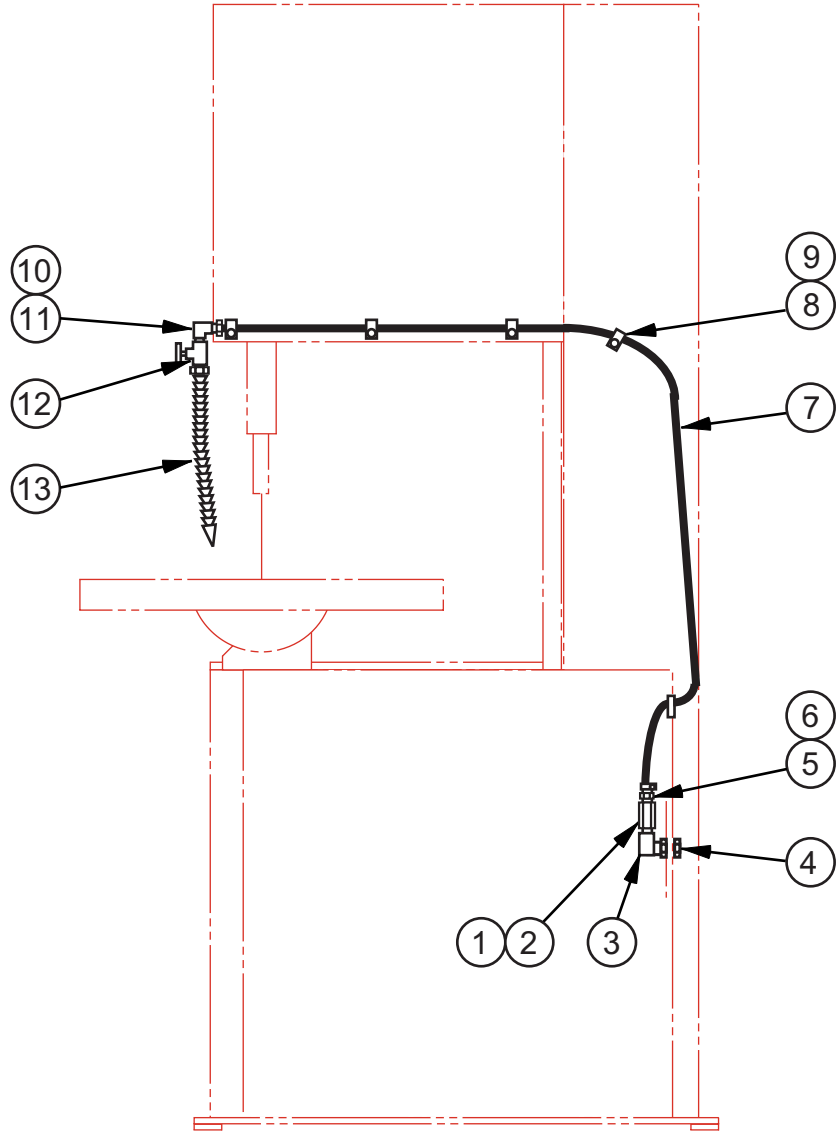

MODEL	FIRST MACH.	LAST MACH.
2013-V	571-04101	
2013-V3	572-04101	
2013-V5	573-04101	
2613-V3	589-09101	

CHIP BLOWER ASSEMBLY (AND RELATED ITEMS)

CHIP BLOWER ASSEMBLY

INDEX NO.	PART NO.	DESCRIPTION	UNITS PER ASS'Y.
Ref.	417302	Chip Blower Assembly	
Ref.	208125	Chip Blower Assembly (w/Sliding Air Table Option)	
1	319526	. Orifice (.038) (Brass)	1
2	201746	. Close Nipple (Brass)	1
3	008254	. 90° Street Elbow	1
4	203818	. Anchor Connector	1
5	002004	. Barbed Insert	1
6	35-006888	. Hose Clamp	1
7	197094	. Neoprene Hose 11/16 O.D.	A.R.
8	115652	. Tubing Clamp	3
9	198366	. Screw, Button Hd. Soc. 1/4-20NC x 3/8	3
10	123041	. 90° Street Elbow	1
11	128179	. Barbed Insert	1
12	120241	. Valve	1
13	172530	. Coolant And Air Hose	1
	172529	. . Connector	1
	197322	. . Segmented Hose (Specify Length)	A.R.
	172528	. . Nozzle	1
When Air Table is Also Supplied:			
14	120857	. Service Tee (Brass)	1
Following Not Shown and Used When Air Compressor Option is Supplied:			
	168156	. Air Compressor (1/8 H.P.)	1
	168614	. Air Compressor (1/4 H.P.)	1
	198026	. Screw, Hex. Hd. Cap 5/16-18NC x 5/8	4
	199323	. Washer, Lock 5/16 Std.	4
	016160	. 90° Cord Grip Connector (.500-.625)	1
	197218	. Electrical Cord (#14-4 Conductor)	A.R.

NEW DRG.
S.C.L. 9-24-97
REVISIONS
S.C.L. 2-25-04
S.C.L. 2-11-08

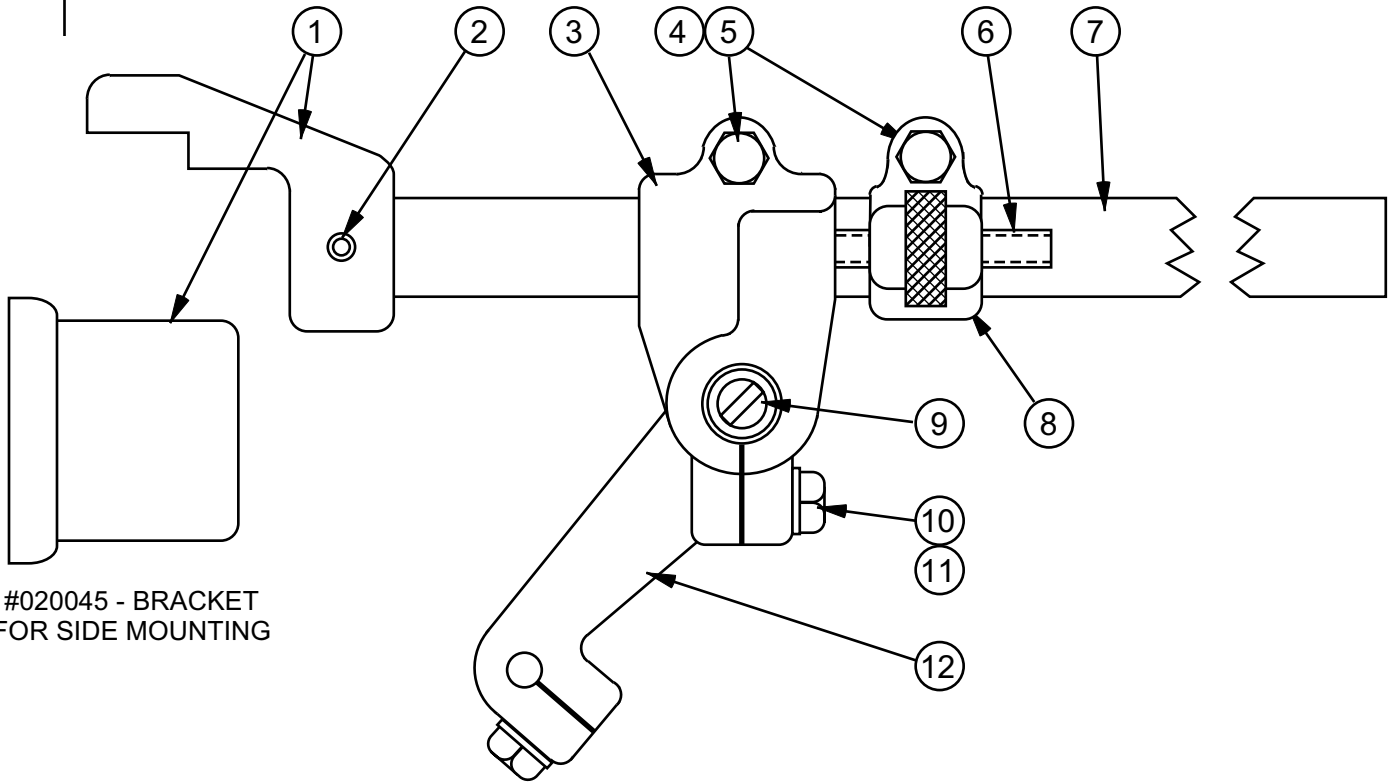

#020045 - BRACKET
FOR SIDE MOUNTING

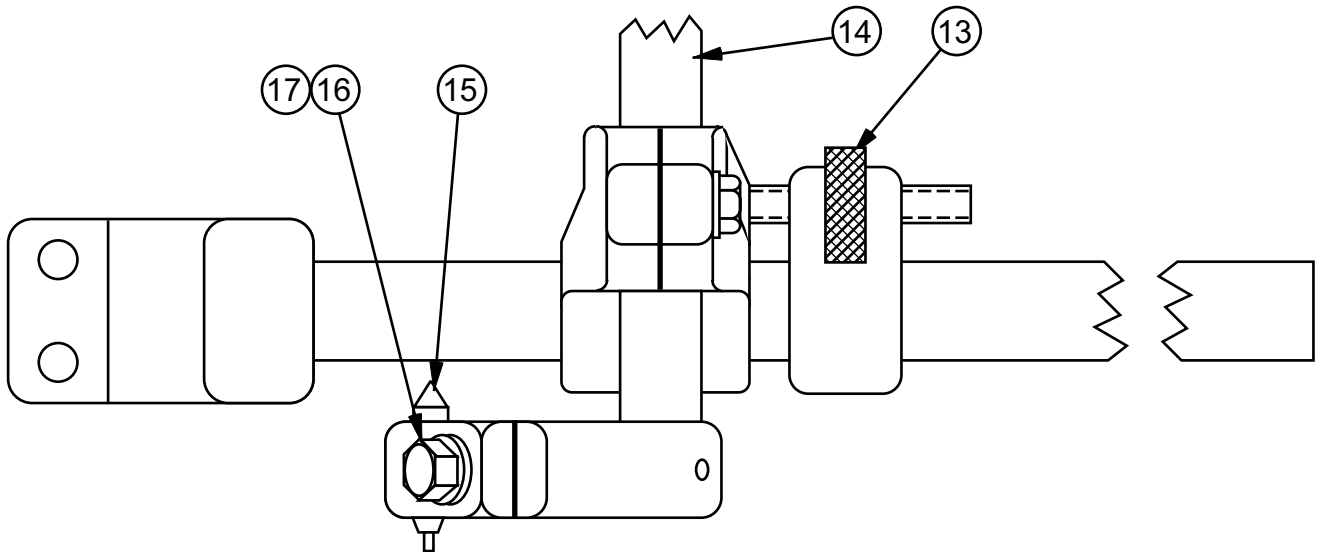

DISC CUTTER ASSEMBLY

C - 10 - 2 CM - 9 - 1 Z - 9 - 4

PRINTED IN U.S.A.

DISC CUTTER ASSEMBLY

INDEX NO.	PART NO.	DESCRIPTION	UNITS PER ASS'Y.
Ref.	402080	Disc Cutter Assembly (Rear Mounted)	
Ref.	040044	Disc Cutter Assembly (Side Mounted)	
1	039019	. Bracket (Rear Mounted)	1
	020045	. Bracket (Side Mounted)	1
2	004276	. Spring Pin (Rear Mounted)	1
	004275	. Spring Pin (Side Mounted)	1
3	35-003400	. Radius Arm Clamp	1
4	198046	. Screw, Hex. Hd. Cap 3/8-16NC x 1	2
5	199325	. Washer, Lock 3/8 Std.	2
6	219409	. Adjustment Rod (w/ #202383 Adhesive)	1
7	35-003399	. Radius Arm	1
8	5-015109	. Adjustment Housing	1
9	004261	. Spring Pin	1
10	198046	. Screw, Hex. Hd. Cap 3/8-16NC x 1	1
11	199325	. Washer, Lock 3/8 Std.	1
12	35-003402	. Center Pin Clamp	1
13	5-015412	. Adjustment Wheel	1
14	35-003401	. Center Adjusting Tube	1
15	5-015415	. Center Pin	1
16	198029	. Screw, Hex. Hd. Cap 5/16-18NC x 1	1
17	199323	. Washer, Lock 5/16 Std.	1

Following Not Shown and Used For Mounting to the Post:

198029	. Screw, Hex. Hd. Cap 5/16-18NC x 1 (Rear Mounted)	2
198031	. Screw, Hex. Hd. Cap 5/16-18NC x 1-1/2 (Side Mounted)	2
199262	. Washer, Flat 5/16 S.A.E. Std.	2
199323	. Washer, Lock 5/16 Std.	2
131797	. Cloth Bag	1
34-020308	. Wrench (If Supplied)	1

NEW DRG.
S.C.L. 2-25-04
REVISIONS
S.C.L. 4-4-07
S.C.L. 2-25-08
S.C.L. 4-10-09

NOTE: BEFORE SERIAL #573-04105 ON 2013-V5 ONLY, ORDER #221755 - LOWER BANDWHEEL AND SHAFT SERVICE KIT TO REPLACE THE FLANGE BEARING AND/OR SHAFT.

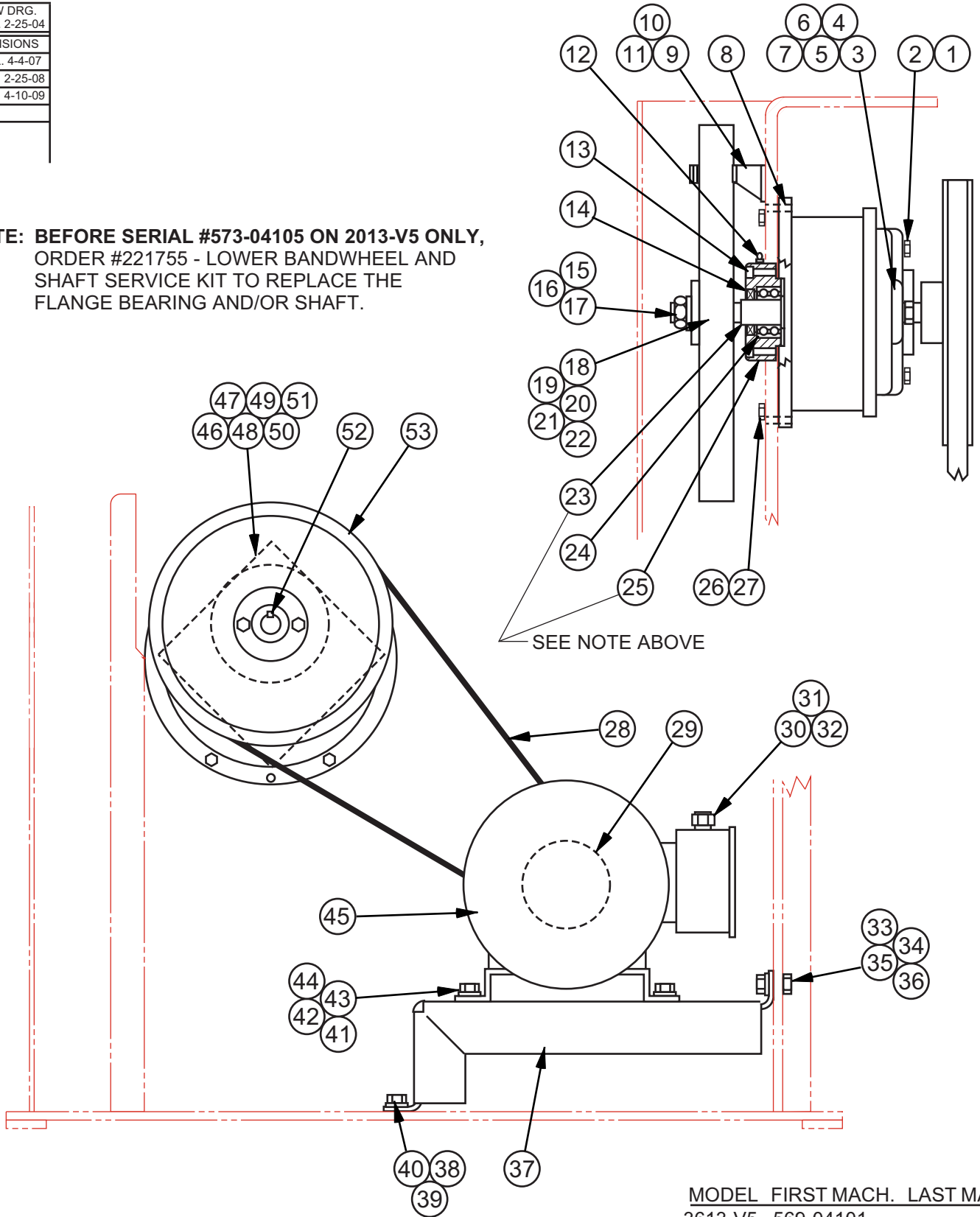

MODEL	FIRST MACH.	LAST MACH.
3613-V5	569-04101	
2013-V5	573-04101	

DRIVE ASSEMBLY

DRIVE ASSEMBLY

INDEX NO.	PART NO.	DESCRIPTION	UNITS PER ASS'Y.
Ref.	218336	Drive Assembly	
1	198096	. Screw, Hex. Hd. Cap 7/16-14NC x 1-1/2	8
2	199333	. Washer, Lock 7/16 Std.	8
3	170498	. Flange Cartridge Bearing	1
4	133570	. Shim (.005)	A.R.
5	133571	. Shim (.008)	A.R.
6	133572	. Shim (.010)	A.R.
7	133573	. Shim (.020)	A.R.
8	260380	. Dowel Pin	2
9	016664	. Brush Holder Weldment	1
10	016684	. Wheel Brush	1
11	199020	. Screw, Pan Hd. Mach. 1/4-20NC x 1/2	2
12	35-001775	. Grease Fitting	2
13	198282	. Screw, Soc. Hd. Cap 3/8-16NC x 1-3/4	4
14	002689	. Oil Seal	1
15	199140	. Nut, Hex. Jam 3/4-10NC	1
16	199378	. Washer, Lock 3/4 Shakeproof Ext.	1
17	199268	. Washer, Flat 3/4 S.A.E. Std.	1
18	039712	. Bandwheel Assembly (Lower) (See Detail)	1
19	5-004604	. Woodruff Key	1
20	133316	. Spacer (.014/.016)	A.R.
21	133317	. Spacer (.028/.032)	A.R.
22	133318	. Spacer (.127/.143)	A.R.
23	421049	. Shaft	1
24	221378	. Ball Bearing	1
25	421019	. Bearing Housing	1
26	198031	. Screw, Hex. Hd. Cap 5/16-18NC x 1-1/2	4
27	199323	. Washer, Lock 5/16 Std.	4
28	209500	. V-Belt	1
29	220218	. Motor Pulley	1
30	015619	. Cord Grip Connector	1
31	014480	. Flange Washer	1
32	015607	. Bond Nut	1
33	198046	. Screw, Hex. Hd. Cap 3/8-16NC x 1	2
34	199325	. Washer, Lock 3/8 Std.	2
35	199264	. Washer, Flat 3/8 S.A.E. Std.	2
36	199126	. Nut, Hex. 3/8-16NC	2
37	518413	. Base Plate Weldment	1
38	198044	. Screw, Hex. Hd. Cap 3/8-16NC x 3/4	2
39	199325	. Washer, Lock 3/8 Std.	2
40	199264	. Washer, Flat 3/8 S.A.E. Std.	2
41	198046	. Screw, Hex. Hd. Cap 3/8-16NC x 1	4
42	199325	. Washer, Lock 3/8 Std.	4
43	199264	. Washer, Flat 3/8 S.A.E. Std.	4
44	199126	. Nut, Hex. 3/8-16NC	4
45	221346	. Electric Motor	1
	221347	. Electric Motor (575V Only)	1
	1011982	. Electric Motor (380V, 60 Hz Only)	1
46	418048	. Bearing Housing Weldment	1
47	133570	. Shim (.005)	A.R.
48	133571	. Shim (.008)	A.R.
49	133572	. Shim (.010)	A.R.
50	133573	. Shim (.020)	A.R.
51	113384	. Shim (.002)	A.R.
52	7-001345	. Key	1
53	220219	. Pulley	1

NEW DRG.
S.C.L. 2-25-04
REVISIONS
S.C.L. 8-21-06
S.C.L. 2-14-08
S.C.L. 8-3-09

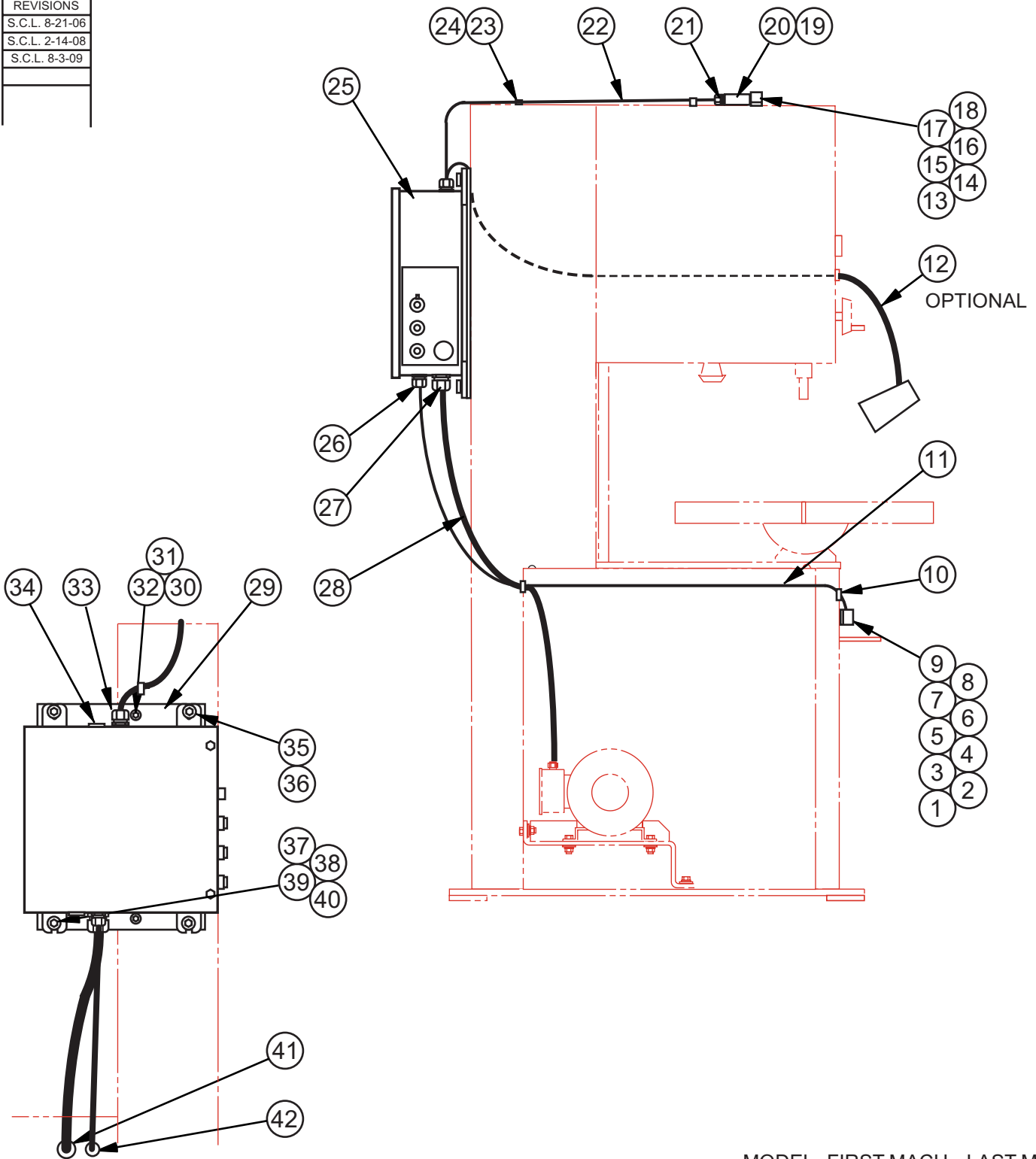

MODEL FIRST MACH. LAST MACH.
 2013-V3 572-04101
 2013-V5 573-04101

ELECTRICAL ASSEMBLY

ELECTRICAL ASSEMBLY

INDEX NO. Ref.	PART NO.	DESCRIPTION	UNITS PER ASS'Y.
		Electrical Assembly	
1	215624	. Limit Switch (Door Interlock)	1
2	199683	. Screw, Soc. Hd. Cap #6-32NC x 1-1/4	2
3	215619	. Cord Grip Connector (.236-.472)	1
4	221855	. Mounting Bracket (Limit Switch Key)	1
5	221854	. Shim (.032)	A.R.
6	198201	. Screw, Soc. Hd. Cap #4-40NC x 3/8	2
7	199255	. Washer, Flat #4 S.A.E. Std.	2
8	199315	. Washer, Lock #4 Std.	2
9	199106	. Nut, Hex. #4-40NC	2
10	133195	. Grommet	1
11	197332	. Electrical Cord (#18-2 Conductor)	A.R.
12	220670	. Worklamp Assembly (Standard Option) (See Detail)	1
	220671	. Worklamp Assembly (Extra Work Height Option) (See Detail)	1
13	221855	. Mounting Bracket (Limit Switch Key)	1
14	221854	. Shim (.032)	A.R.
15	198201	. Screw, Soc. Hd. Cap #4-40NC x 3/8	4
16	199255	. Washer, Flat #4 S.A.E. Std.	4
17	199315	. Washer, Lock #4 Std.	4
18	199106	. Nut, Hex. #4-40NC	4
19	215624	. Limit Switch (Door Interlock)	1
20	199683	. Screw, Soc. Hd. Cap #6-32NC x 1-1/4	2
21	215619	. Cord Grip Connector (.236-.472)	1
22	197332	. Electrical Cord (#18-2 Conductor)	A.R.
23	009955	. Hose Clip	3
24	198210	. Screw, Soc. Hd. Cap #8-32NC x 3/8	3
25		. Electrical Control Box Assembly (See Detail)	1
26	201688	. Cord Grip Connector (.200-.394)	1
27	201687	. Cord Grip Connector (.545-.709)	1
28	197367	. Electrical Cord (#10-3 Conductor) (115V, 1 Phase)	A.R.
	197225	. Electrical Cord (#12-3 Conductor) (220V, 1 Phase)	A.R.
	197218	. Electrical Cord (#14-4 Conductor) (3 Phase Motors)	A.R.
29	417838	. Mounting Plate	1
30	198008	. Screw, Hex. Hd. Cap 1/4-20NC x 3/4	2
31	199321	. Washer, Lock 1/4 Std.	2
32	199260	. Washer, Flat 1/4 S.A.E. Std.	2
33	201688	. Cord Grip Connector (.200-.394)	1
34	135106	. Hole Seal (When Worklight Not Supplied)	1
35	198027	. Screw, Hex. Hd. Cap 5/16-18NC x 3/4	2
36	199262	. Washer, Flat 5/16 S.A.E. Std.	2
37	198027	. Screw, Hex. Hd. Cap 5/16-18NC x 3/4	2
38	199262	. Washer, Flat 5/16 S.A.E. Std.	2
39	199122	. Nut, Hex. 5/16-18NC	2
40	199323	. Washer, Lock 5/16 Std.	2
41	007506	. Grommet	1
42	133195	. Grommet	1
Following Not Shown:			
	009135	. Escutcheon (Limit Switch No.)	2
	199397	. Screw, Rd. Hd. Drive #2 x 1/4	4

NEW DRG.
S.C.L. 9-15-14
REVISIONS

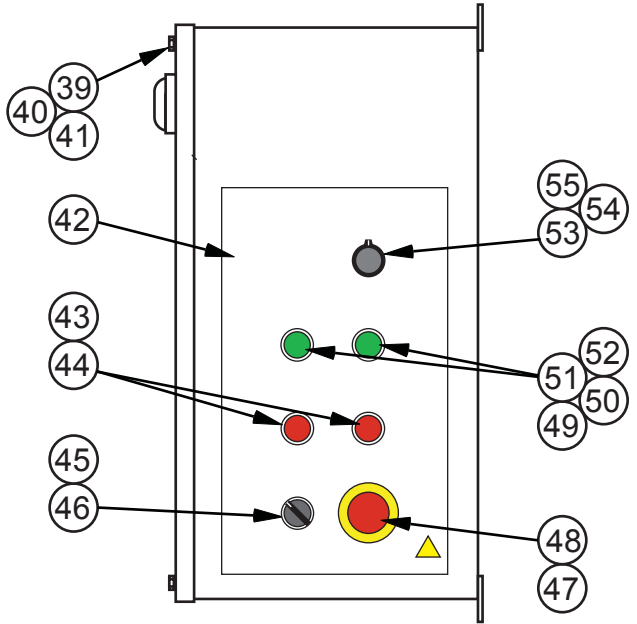
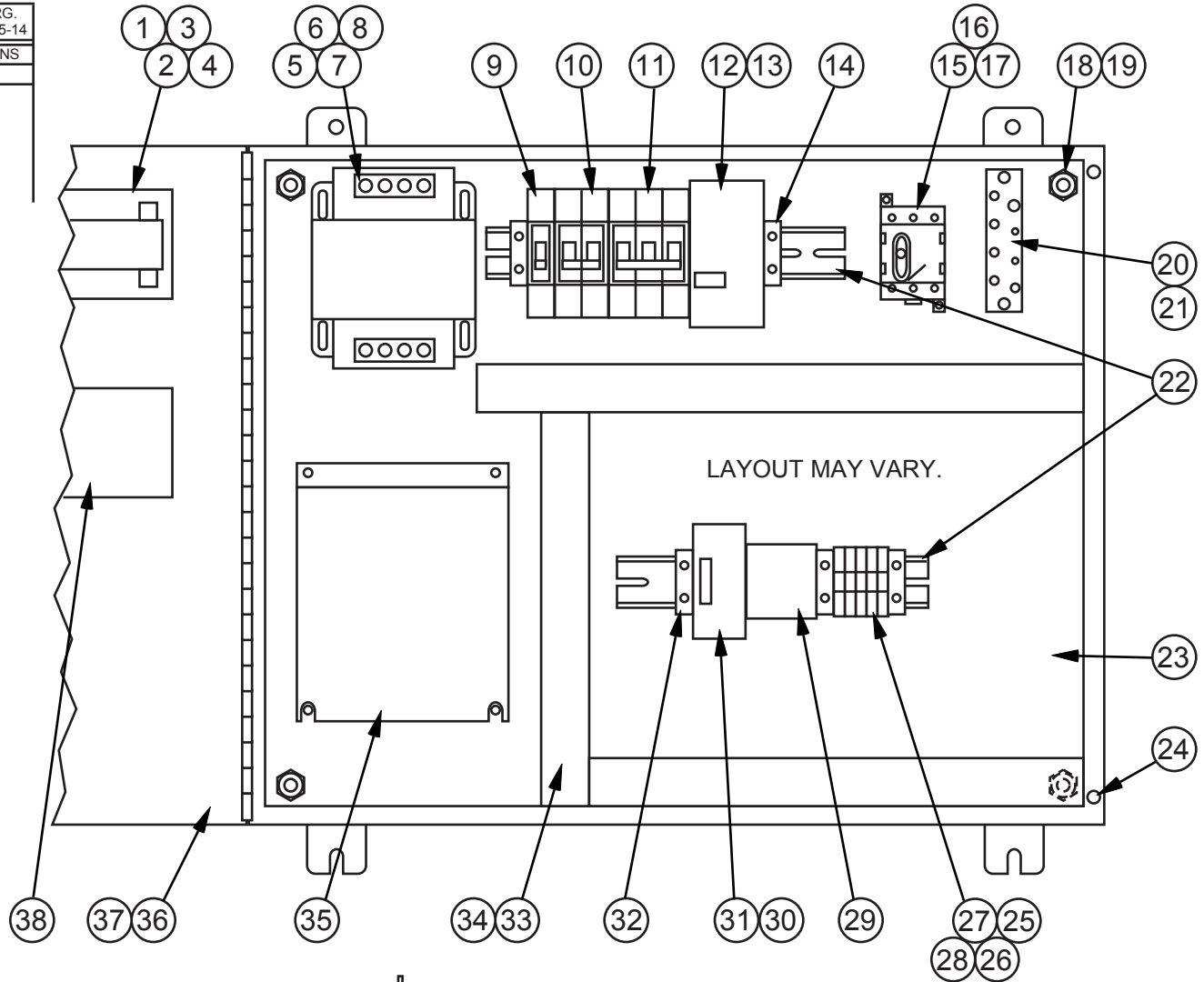

MODEL FIRST MACH. LAST MACH.
2013-V5 573-14108

ELECTRICAL CONTROL BOX ASSEMBLY

ELECTRICAL CONTROL BOX ASSEMBLY

INDEX NO.	PART NO.	DESCRIPTION	UNITS PER ASS'Y.	INDEX NO.	PART NO.	DESCRIPTION	UNITS PER ASS'Y.
Ref.	226256	Electrical Control Box Assembly		39	207523	. Screw, Hex. Hd. Slotted M6-1.0 x 20 ...	2
1	208728	. Mounting Bracket	2	40	204153	. Nylon Washer	2
2	207786	. Resistor (30 Ohm) (208V, 220V, 230V)	1	41	204151	. Retainer	2
	219330	. Resistor (160 Ohm) (380V, 400V, 460V)	1	42	325692	. Escutcheon	1
3	208719	. Resistor Cover	1	43	207189	. Pushbutton Operator (Red)	2
4	107777	. Plastic Rivet	2	44	207186	. Contact Block (1-NC)	2
5	319088	. Transformer (208V, 380V)	1	45	207181	. Selector Switch (2 Position) (Worklamp Option)	1
	319078	. Transformer (230V, 460V, 575V)	1	46	207185	. Contact Block (1-NO) (Worklamp Option)	1
	217752	. Transformer (400V)	1	47	207191	. Pushbutton Operator (Red Mushroom)	1
6	199202	. Nut, Hex. M5-0.8	4	48	207186	. Contact Block (1-NC)	1
7	199348	. Washer, Lock M5	4	49	207192	. Pushbutton Operator (Illuminous Green)	1
8	199244	. Washer, Flat M5	4	50	207193	. Power Supply	1
9	420356	. Circuit Breaker	1	51	207185	. Contact Block (1-NO)	1
10	1007399	. Circuit Breaker (208V, 220V, 230V)	1	52	205115	. Seal Boot	1
	1007397	. Circuit Breaker (380V, 400V)	1	53	178146	. Knob	1
	1007405	. Circuit Breaker (460V)	1	54	223553	. Potentiometer (Mitsubishi VFDs)	1
11	1007427	. Circuit Breaker (230V)	1	55	203732	. Potentiometer Operator Kit	1
12	220645	. Motor Starter Protector (208V, 220V, 230V)	1				
	220648	. Motor Starter Protector (380V, 400V, 460V)	1		Not Shown:		
13	220654	. Auxiliary Contact (1-NO)	1		1003427	. U.L. Label	1
14	200618	. End Stop	2		1012541	. Label (Machine Specifications)	1
15	1007434	. Disconnect Switch	1		197341	. Wire, #12 Black (19 Strand)	A.R.
16	1007440	. Disconnect Switch Shaft	1		197186	. Wire, #12 Green/Yellow (19 Strand)	A.R.
17	1007439	. Disconnect Switch Handle	1		197325	. Wire, #16 White (19 Strand)	A.R.
18	199126	. Nut, Hex. 3/8-16NC	4		197197	. Wire, #16 Red (19 Strand)	A.R.
19	199325	. Washer, Lock 3/8 Std.	4		197343	. Wire, #16 Green/Yellow (19 Strand)	A.R.
20	320740	. Grounding Bus	1				
21	141639	. Wire Terminal Lug	1				
22	169674	. Mounting Channel	A.R.				
23	520141	. Control Panel	1				
24	207525	. Rivet Nut M6-1.0	2				
25	200615	. Terminal Block	5				
26	200617	. End Section	1				
27	200618	. End Stop	3				
28	208716	. Terminal Block Marker Set	A.R.				
29	207200	. Control Relay	1				
30	207207	. Contactor	1				
31	207219	. Auxiliary Contact	1				
32	200618	. End Stop	2				
33	197208	. 1" Wiring Channel	A.R.				
34	197210	. 1" Wiring Channel Cover	A.R.				
35	1007741	. Variable Speed Controller (208V, 220V, 230V)	1				
	1007742	. Variable Speed Controller (380V, 400V 460V)	1				
	220627	. Variable Speed Controller (575V)	1				
36	522120	. Enclosure Weldment	1				
37	203925	. Gasket Strip	A.R.				
38	226255	. CB and MSP Schedule	1				
	226075	. CB and MSP Schedule (380V, 60 Hz) .	1				

NEW DRG.
S.C.L. 7-31-03
REVISIONS
S.C.L. 2-25-04
S.C.L. 8-16-06
S.C.L. 9-11-07
S.C.L. 2-8-08
S.C.L. 8-3-09

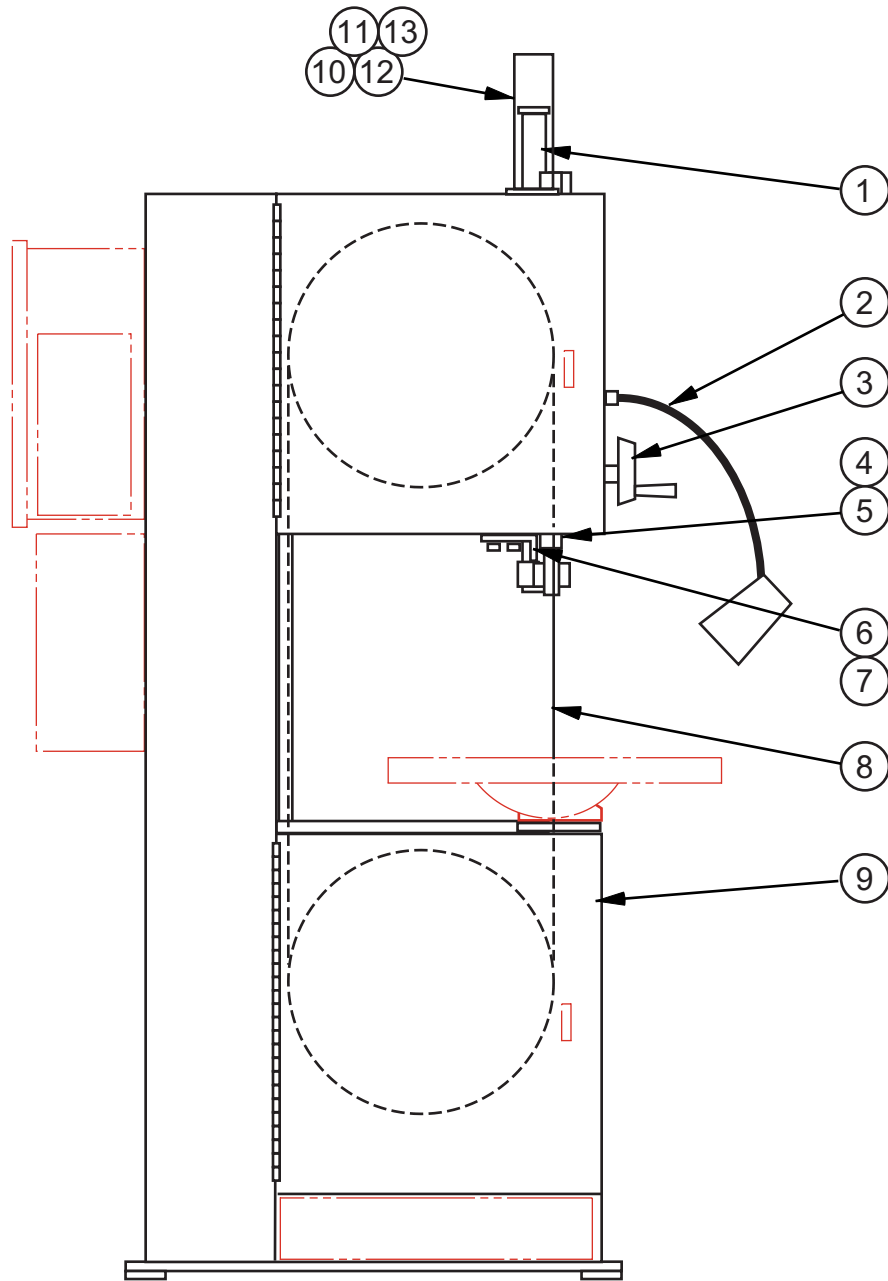

MODEL	FIRST MACH.	LAST MACH.
2012-VH	561-03101	
2013-V	571-04101	
2013-V3	572-04101	
2013-V5	573-04101	

EXTRA WORK HEIGHT ASSEMBLY

C - 2 - 119 CM - 2 - 129

PRINTED IN U.S.A.

EXTRA WORK HEIGHT ASSEMBLY

INDEX NO.	PART NO.	DESCRIPTION	UNITS PER ASS'Y.
Ref.	216820	19" Work Height Assembly (2019-V, 2019-V3, 2019-V5)	
Ref.	220734	18" Work Height Assembly (2018-VH, 2018-D12)	
Ref.	216822	25" Work Height Assembly (2025-V, 2025-V3, 2025-V5)	
Ref.	220735	24" Work Height Assembly (2024-VH, 2024-D12)	
Ref.	216823	31" Work Height Assembly (2031-V, 2031-V3, 2031-V5)	
Ref.	220736	30" Work Height Assembly (2030-VH, 2030-D12)	
1	506149	. Auxiliary Post Support Assembly (Work Heights Over 19") (See Detail)	1
2	220671	. Worklamp Assembly (Optional)	1
3	407860	. Post Elevating Handwheel Assembly (18" and 19" Work Heights) (See Detail)	1
	407729	. Post Elevating Handwheel Assembly (24" and 25" Work Heights) (See Detail)	1
	407618	. Post Elevating Handwheel Assembly (30" and 31" Work Heights) (See Detail)	1
4	306436	. Saw Band Guard Assembly (18" and 19" Work Heights)	1
	306312	. Saw Band Guard Assembly (24" and 25" Work Heights)	1
	305508	. Saw Band Guard Assembly (30" and 31" Work Heights)	1
	316926	. . Guard Weldment (18" and 19" Work Heights)	1
	316927	. . Guard Weldment (24" and 25" Work Heights)	1
	316923	. . Guard Weldment (30" and 31" Work Heights)	1
	316934	. . Guard Slide Cover	1
	133372	. . Thumb Screw	1
5	105304	. Spring Pin (Work Heights Over 19" Only)	1
6*	326503	. Guard Slide (Post) (8-5/8") (V, V3, V5 Only)	1
*	326504	. Guard Slide (Post) (14-5/8") (V, V3, V5 Only)	1
*	326505	. Guard Slide (Post) (20-5/8") (V, V3, V5 Only)	1
*	325695	. Guard Slide (Post) (6-5/8") (VH, D12 Only)	1
*	325696	. Guard Slide (Post) (12-5/8") (VH, D12 Only)	1
*	325697	. Guard Slide (Post) (18-5/8") (VH, D12 Only)	1
7	133372	. Thumb Screw	2
8	171509	. Saw Band (Super Silencer) (18" and 19" Work Heights)	1
	216825	. Saw Band (Super Silencer) (24" and 25" Work Heights) (V, V3, V5 Only)	1
	171510	. Saw Band (Super Silencer) (24" and 25" Work Heights) (VH, D12 Only)	1
	171511	. Saw Band (Super Silencer) (30" and 31" Work Heights)	1
9	220681	. Frame Weldment (18" and 19" Work Heights)	1
	220682	. Frame Weldment (24" and 25" Work Heights)	1
	220683	. Frame Weldment (30" and 31" Work Heights)	1
10	326507	. Post Screw Cover Weldment (24", 25", 30", 31" Post Elevating Handwheel Options)	1
11	198007	. Screw, Hex. Hd. Cap 1/4-20NC x 5/8	4
12	199321	. Washer, Lock 1/4 Std.	4
13	199115	. Nut, Hex. 1/4-20NC	4

*NOTE: Use These Interchangeable Guard Slides When Applicable.
Be Sure To Use The Guard Slide That Will Cover Exposed Saw Band Completely.

NEW DRG.
S.C.L. 2-25-04
REVISIONS
S.C.L. 9-9-07
S.C.L. 2-11-08

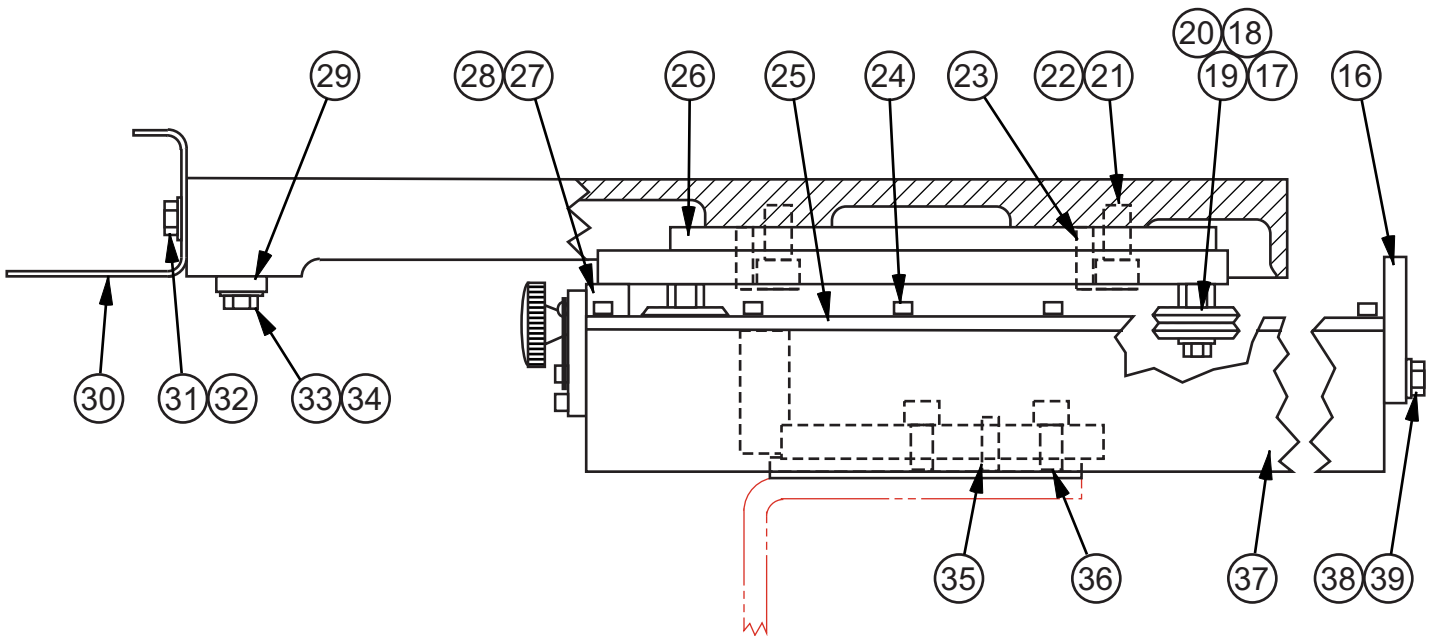
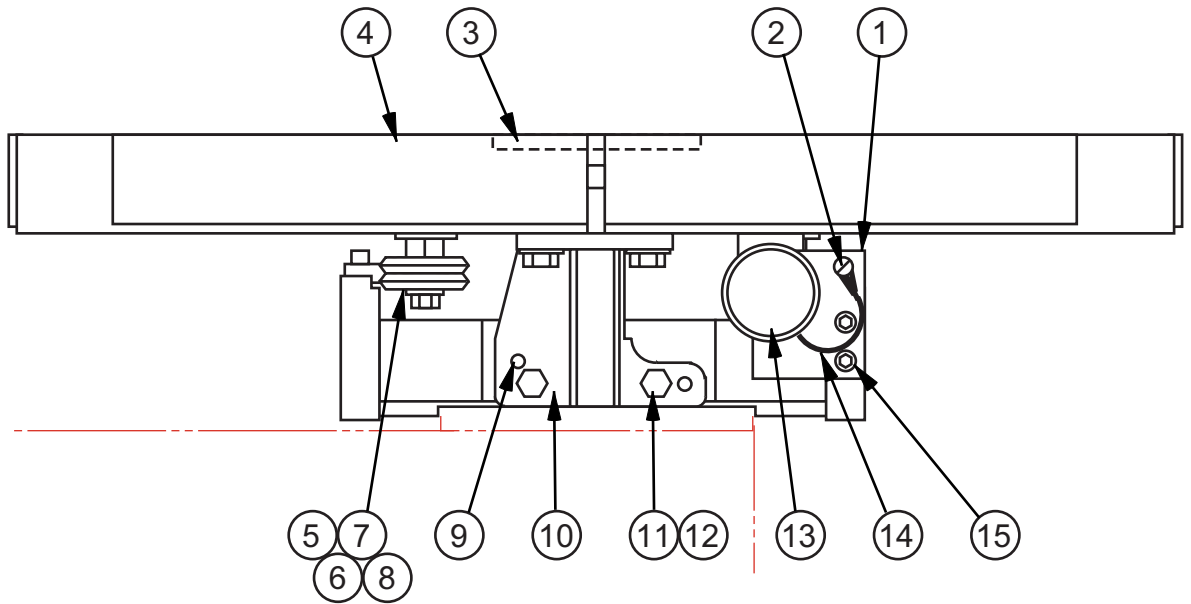

GLIDE TABLE ASSEMBLY

GLIDE TABLE ASSEMBLY

INDEX NO.	PART NO.	DESCRIPTION	UNITS PER ASSY.
Ref.	208104	Glide Table Assembly (12" Stroke)	
Ref.	220893	Glide Table Assembly (18" Stroke)	
1	208103	. Stop Plate (12" Stroke)	1
	220880	. Stop Plate (18" Stroke)	1
2	198346	. Screw, Button Hd. Soc. #8-32NC x 3/8	1
3	316903	. Center Plate (Oval)	1
4	514113	. Table (12" Stroke)	1
	521541	. Table Weldment (18" Stroke)	1
5	208038	. Guide Wheel	3
6	208036	. Bushing Adaptor (L.H. Side)	3
7	198031	. Screw, Hex. Hd. Cap 5/16-18NC x 1-1/2	3
8	199323	. Washer, Lock 5/16 Std.	3
9	35-000516	. Dowel Pin	2
10	321271	. Lower Post Block	1
11	198046	. Screw, Hex. Hd. Cap 3/8-16NC x 1	2
12	199325	. Washer, Lock 3/8 Std.	2
13	208041	. Thumbscrew Weldment	1
14	208102	. Lanyard	1
15	198238	. Screw, Soc. Hd. Cap 1/4-20NC x 5/8	2
16	320999	. End Bar (12" Stroke)	1
	325833	. End Bar Weldment (18" Stroke)	1
17	208038	. Guide Wheel	3
18	208035	. Adjustable Bushing Adaptor (R.H. Side)	3
19	198031	. Screw, Hex. Hd. Cap 5/16-18NC x 1-1/2	3
20	199323	. Washer, Lock 5/16 Std.	3
21	198295	. Screw, Soc. Hd. Cap 1/2-13NC x 1-1/2	4
22	199327	. Washer, Lock 1/2 Std.	4
23	198441	. Screw, Soc. Set 5/16-18NC x 1-1/4	4
24	198238	. Screw, Soc. Hd. Cap 1/4-20NC x 5/8	18
25	208037	. Track (12" Stroke)	2
	220874	. Track (18" Stroke)	2
26	418051	. Roller Support Weldment (12" Stroke)	1
	325872	. Glide Table Plate (18" Stroke)	1
27	209106	. Stop Block (12" Stroke)	1
	220889	. Stop Block (18" Stroke)	1
28	199811	. Screw, Button Hd. Soc. 1/4-20NC x 1-1/2	2
29	004599	. Front Table Clamp	1
30	418419	. Glide Table Handle	1
31	198044	. Screw, Hex. Hd. Cap 3/8-16NC x 3/4	2
32	199264	. Washer, Flat 3/8 S.A.E. Std.	2
33	198046	. Screw, Hex. Hd. Cap 3/8-16NC x 1	2
34	199264	. Washer, Flat 3/8 S.A.E. Std.	2
35	14-00473	. Dowel Pin	2
36	198293	. Screw, Soc. Hd. Cap 1/2-13NC x 1	3
37	517672	. Table Support Weldment (12" Stroke)	1
	521540	. Table Support Weldment (18" Stroke)	1
38	198046	. Screw, Hex. Hd. Cap 3/8-16NC x 1	2
39	199325	. Washer, Lock 3/8 Std.	2

NEW DRG. S.C.L. 10-29-97
REVISIONS
S.C.L. 6-29-01
S.C.L. 2-25-04
S.C.L. 2-11-08
S.C.L. 8-3-09

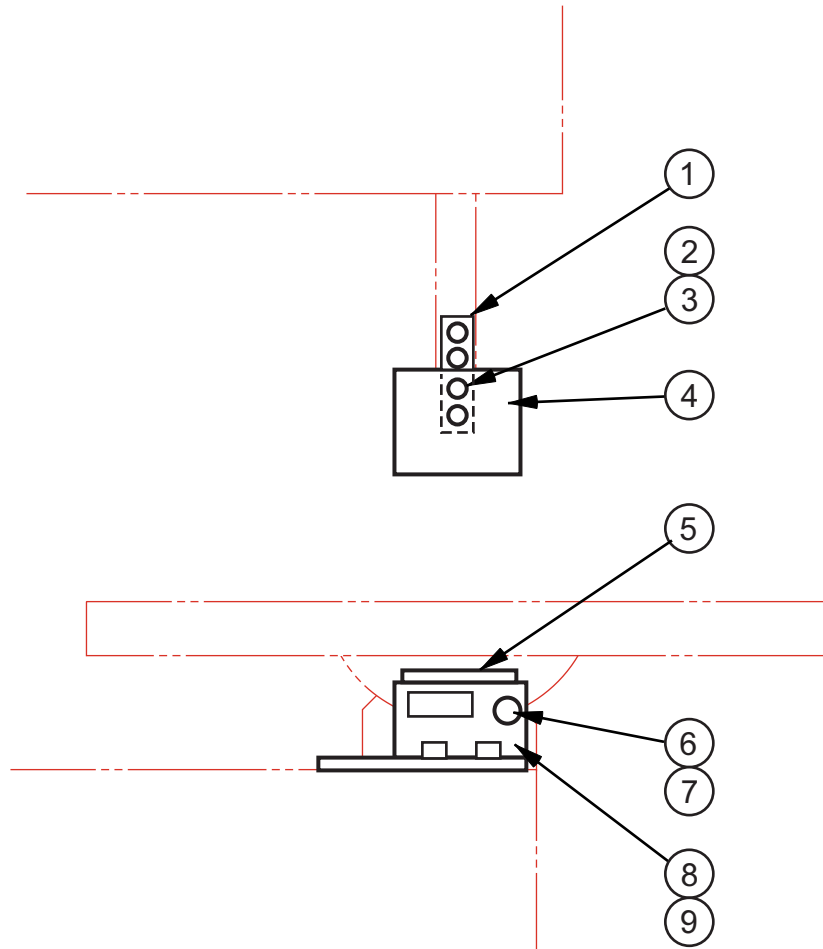

MODEL	FIRST MACH.	LAST MACH.
2013-V	500-92101	500-042942
2013-V3	526-95101	526-03579
2013-V5	551-01101	551-04106
2013-V	571-04101	
2013-V3	572-04101	
2013-V5	573-04101	
2613-V3	589-09101	

GUARD ASSEMBLY (POINT OF OPERATION)

C - 10 - 49

GUARD ASSEMBLY
(Point of Operation)

INDEX NO.	PART NO.	DESCRIPTION	UNITS PER ASS'Y.
Ref.	417086	Guard Assembly (Point of Operation)	
1	213713	. Guard Mounting Plate	1
2	146046	. Thumb Screw Assembly	2
	131086	. . Knob	1
	198219	. . Screw, Soc. Hd. Cap #10-24NC x 3/8	1
3	203546	. Spacer	1
4	319337	. Upper Guard (Plexiglas)	1
5	417085	. Telescoping Guard.....	1
6	417084	. Lower Guard	1
7	203145	. Escutcheon (Guard Position).....	1
8	133372	. Thumb Screw	1
9	203098	. Nut Plate 1/4-20NC.....	1

NEW DRG.
S.C.L. 2-25-04
REVISIONS
S.C.L. 2-11-08

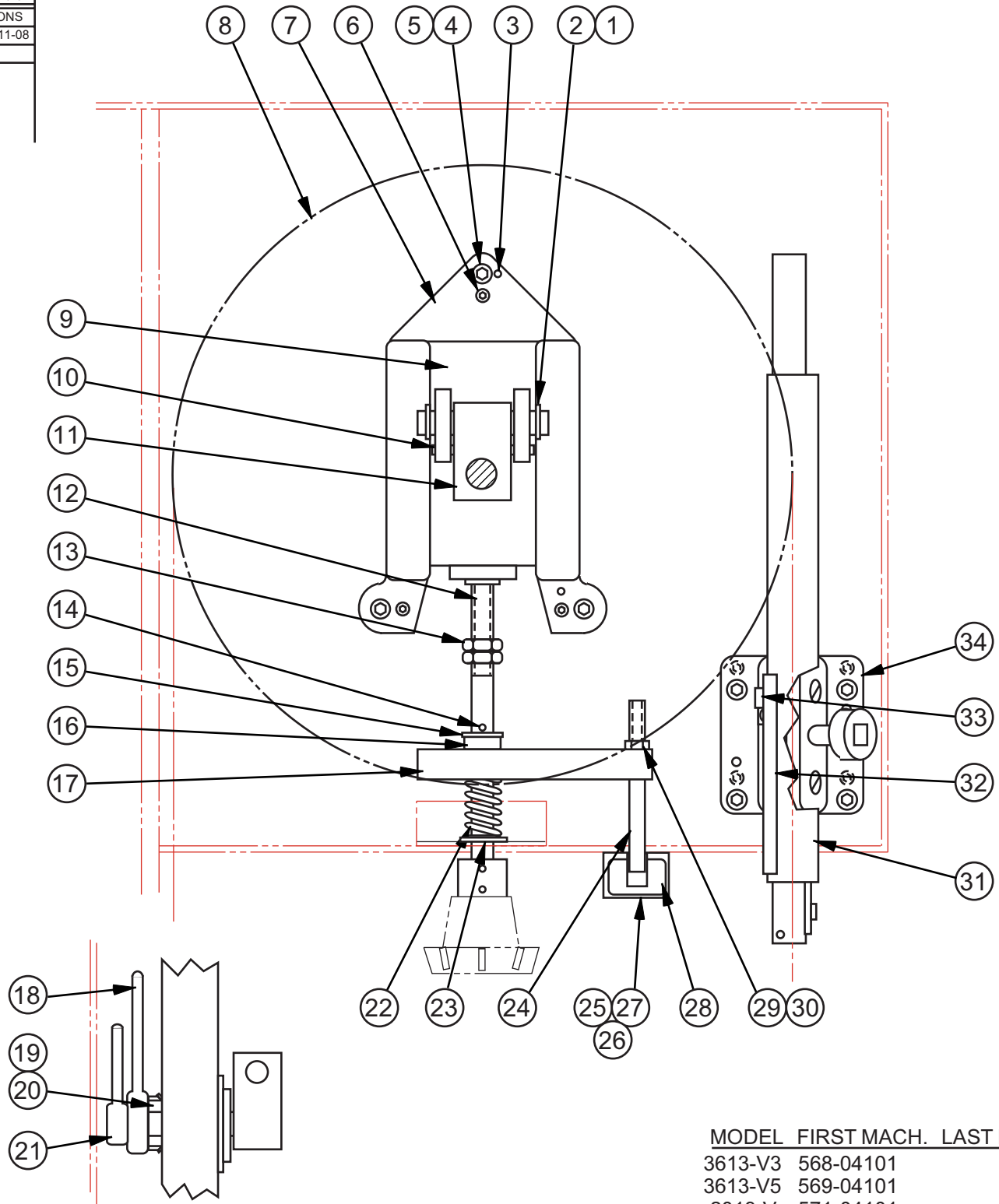

MODEL	FIRST MACH.	LAST MACH.
3613-V3	568-04101	
3613-V5	569-04101	
2013-V	571-04101	
2013-V3	572-04101	
2013-V5	573-04101	
3613-1	577-04101	

HEAD ASSEMBLY

HEAD ASSEMBLY

INDEX NO.	PART NO.	DESCRIPTION	UNITS PER ASSY.
Ref.	520279	Head Assembly	
1	120627	. Pin	1
2	35-009613	. Retaining Ring	2
3	004265	. Spring Pin	2
4	198264	. Screw, Soc. Hd. Cap 5/16-18NC x 2	3
5	199323	. Washer, Lock 5/16 Std.	3
6	198440	. Screw, Soc. Set 5/16-18NC x 1	3
7	504621	. Head Casting	1
8	402598	. Bandwheel Assembly (See Detail)	1
9	415369	. Head Slide Weldment	1
10	178228	. Screw, Soc. Set 1/4-20NC x 5/8 (Self Locking, Half Dog Point)	2
11	302346	. Wheel Hinge Assembly (See Detail)	1
12	319429	. Band Tension Screw Sub-Assembly	1
	203548	. . Adaptor	1
	139123	. . Screw	1
	004261	. . Spring Pin	1
13	199132	. Nut, Hex. Jam 1/2-13NC	2
14	004259	. Spring Pin	1
15	199266	. Washer, Flat 1/2 S.A.E. Std.	2
16	35-002810	. Thrust Ball Bearing	1
17	144062	. Angle	1
18	319252	. Lock Handle	1
19	5-001506	. Bearing Locknut	1
20	5-001507	. Bearing Lockwasher	1
21	319251	. Tilting Screw Handle (w/Stud)	1
22	35-008761	. Compression Spring	1
23	199267	. Washer, Flat 5/8 S.A.E. Std.	1
24	142250	. Band Tension Pointer	1
25	198001	. Screw, Hex. Hd. Cap #10-24NC x 1/2	2
26	199320	. Washer, Lock #10 Std.....	2
27	199111	. Nut, Hex. #10-24NC	2
28	117737	. Escutcheon (Band Tension) (Inch/English)	1
	131424	. Escutcheon (Band Tension) (Metric/International)	1
29	199123	. Nut, Hex. Jam 5/16-18NC	2
30	163080	. Retaining Compound (Loctite #271)	A.R.
31*	316925	. Guard Weldment (Standard)	1
32	316934	. Guard Slide Cover	1
33	133372	. Thumb Screw	1
34*	216836	. Post Assembly (Standard) (2013-V, 2013-V3, 2013-V5) (See Detail) .	1
*	221771	. Post Assembly (Standard) (3613-1, 3613-V3, 3613-V5) (See Detail) ..	1
*	404971	. Post Elevating Handwheel Assembly (Standard - Optional) (See Detail)	1

*NOTE: See Extra Work Height Assembly If Applicable.

Following Not Shown:

148368	. Escutcheon (Post - Raise/Lower) (International)	1
199396	. Screw, Rd. Hd. Drive #2 x 3/16	3

NEW DRG. S.C.L. 3-17-09
REVISIONS

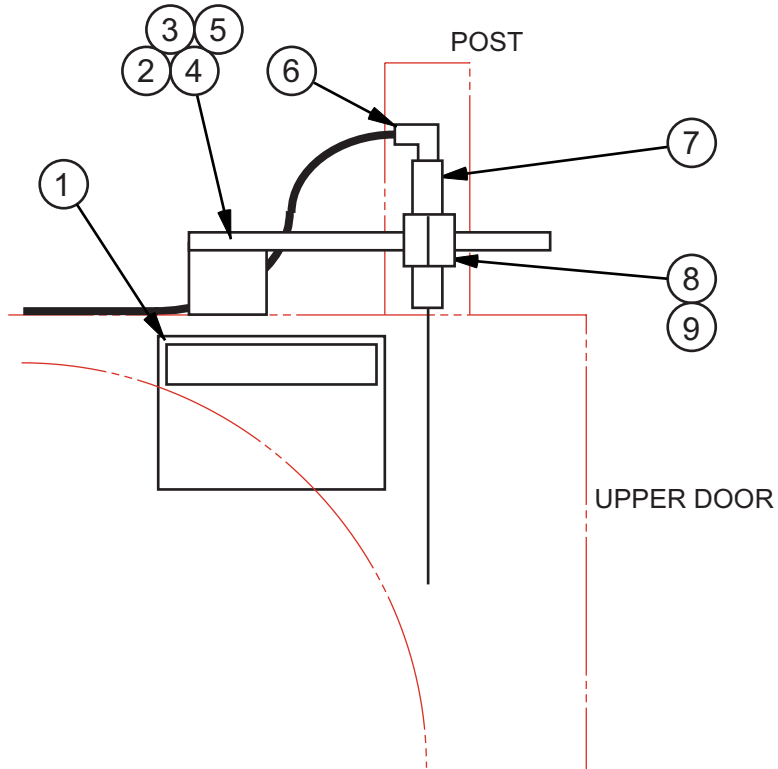

MODEL	FIRST MACH.	LAST MACH.
2012-VH	561-03101	
ZV-3620	565-03101	
3613-V3	568-04101	
3613-V5	569-04101	
3612-VH	570-04101	
2013-V	571-04101	
2013-V3	572-04101	
2013-V5	573-04101	
3613-1	577-04101	
2012-D12	584-08101	

LASER LINE GENERATOR ASSEMBLY

C - 10 - 65 CM - 10 - 45 Z - 10 - 33

PRINTED IN U.S.A.

LASER LINE GENERATOR ASSEMBLY

INDEX NO. Ref.	PART NO.	DESCRIPTION	UNITS PER ASS'Y.
		Laser Line Generator Assembly	
1	212884	. Label (Caution - Laser)	1
2	326740	. Laser Mounting Bracket Weldment	1
	322740	. Laser Mounting Bracket Weldment (ZV-3620 Only)	1
3	199923	. Screw, Soc. Hd. Cap M6-1.0 x 10	2
4	199965	. Washer, Flat M6	2
5	199347	. Washer, Lock M6	2
6	222859	. Laser Cordset	1
7	223548	. Laser Line Generator (Red) (24VDC)	1
8	322650	. Laser Holder	1
9	199993	. Screw, Soc. Hd. Cap M6-1.0 x 20	2

NEW DRG.
S.C.L. 2-25-04
REVISIONS
S.C.L. 8-16-06
S.C.L. 2-11-08
S.C.L. 8-3-09

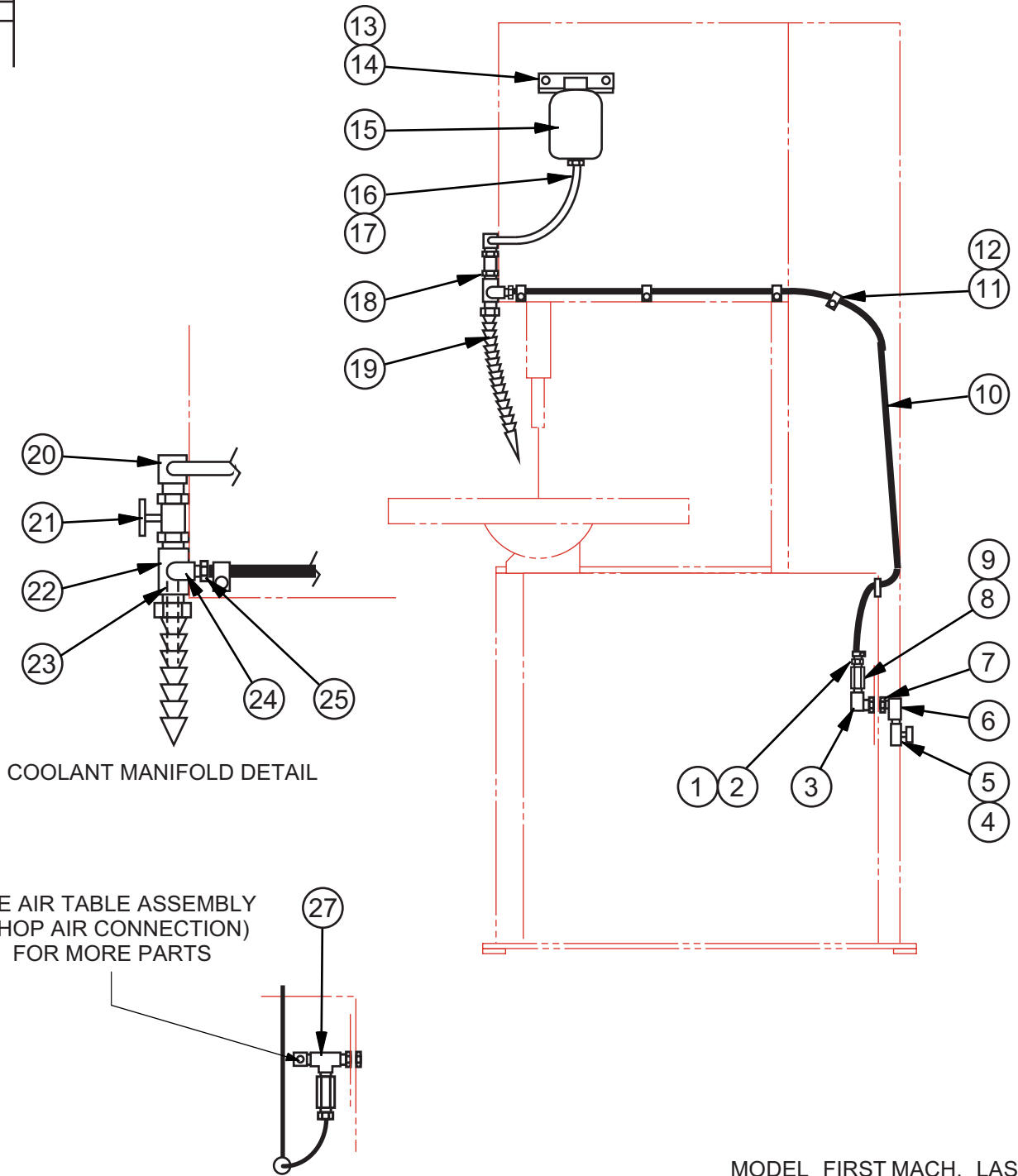

COOLANT MANIFOLD DETAIL

SEE AIR TABLE ASSEMBLY
(SHOP AIR CONNECTION)
FOR MORE PARTS

WHEN AIR TABLE IS
ALSO SUPPLIED

MODEL	FIRST MACH.	LAST MACH.
2013-V	571-04101	
2013-V3	572-04101	
2013-V5	573-04101	
2613-V3	589-09101	

MIST COOLANT ASSEMBLY (AND RELATED ITEMS)

MIST COOLANT ASSEMBLY

INDEX NO.	PART NO.	DESCRIPTION	UNITS PER ASS'Y.
Ref.	517518	Mist Coolant Assembly	
Ref.	208126	Mist Coolant Assembly (w/Sliding Air Table Option)	
1	002004	. Barbed Insert	1
2	35-006888	. Hose Clamp	1
3	008254	. 90° Street Elbow	1
4	178934	. Ball Valve	1
5	201746	. Close Nipple (Brass)	1
6	008254	. 90° Street Elbow	1
7	203818	. Anchor Connection	1
8	319526	. Orifice (.038) (Brass)	1
9	201746	. Close Nipple (Brass)	1
10	197094	. Neoprene Hose 11/16 O.D. (Black)	A.R.
11	115652	. Tubing Clamp	3
12	198366	. Screw, Button Hd. Soc. 1/4-20NC x 3/8	3
13	303956	. Bracket	1
14	199476	. Screw, Rd. Hd. Self-Tap 1/4-20NC x 3/4	2
15	136918	. Bottle Assembly	1
16	197144	. Plastic Tubing 3/8 O.D. (Clear)	A.R.
17	104713	. Hose Clamp	2
18	038303	. Coolant Manifold Assembly (Standard)	1
	038304	. Coolant Manifold Assembly (19" Work Height)	1
	307334	. Coolant Manifold Assembly (25" Work Height)	1
	311565	. Coolant Manifold Assembly (31" Work Height)	1
19	172530	. . Coolant And Air Hose (Standard)	1
	172531	. . Coolant And Air Hose (19" Work Height)	1
	172532	. . Coolant And Air Hose (25" Work Height)	1
	172533	. . Coolant And Air Hose (31" Work Height)	1
	172529	. . . Connector	1
	197322	. . . Segmented Hose (Specify Length)	A.R.
	172528	. . . Nozzle	1
20	108116	. 90° Barbed Insert	1
21	5-027507	. . Sight Feed Valve	1
22	119910	. . Manifold	1
23	121061	. . Coolant Tube Assembly	1
	197140	. . . Nylon Tubing .089 O.D. (Cut to Length)	A.R.
	136893	. . . Glue (Meta Grip #3802)	A.R.
	119912	. . . Pipe Plug	1
24	5-004520	. 90° Street Elbow	1
25	128179	. Barbed Insert	1
26	35-006888	. Hose Clamp	1
27	120857	When Air Table is Also Supplied: . Service Tee	1

NEW DRG.
S.C.L. 9-25-97
REVISIONS
S.C.L. 2-25-04
S.C.L. 2-11-08

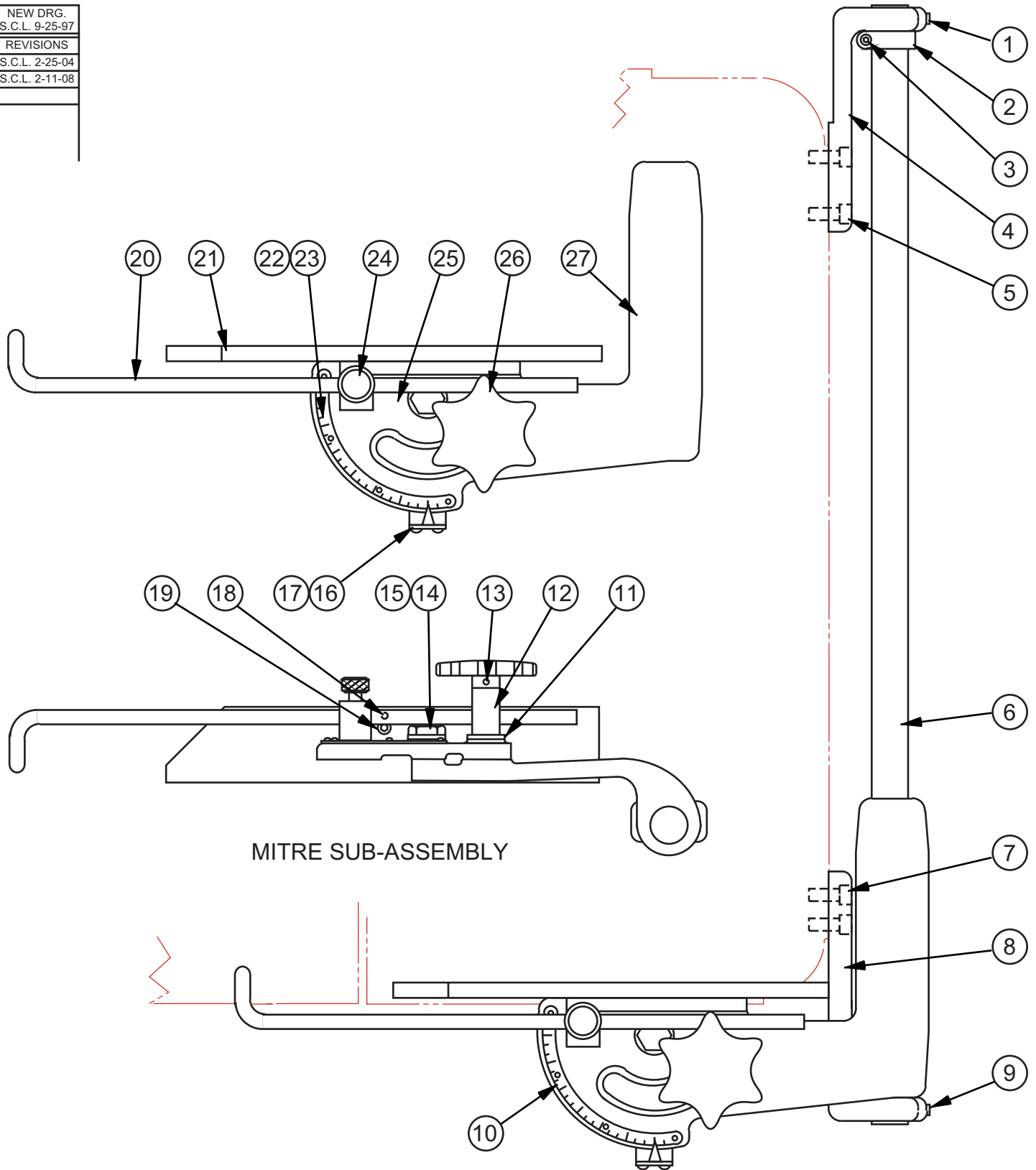

MITRE SUB-ASSEMBLY

MITRE ASSEMBLY (NO. 2 STANDARD CUT-OFF)

C - 10 - 28 Z - 10 - 6

PRINTED IN U.S.A.

MITRE ASSEMBLY

INDEX NO.	PART NO.	DESCRIPTION	UNITS PER ASS'Y.
Ref.	050419	Mitre Assembly (No. 2 Standard Cut-Off) (20" Table)	
Ref.	055290	Mitre Assembly (No. 2 Standard Cut-Off) (24" Table)	
Ref.	055305	Mitre Assembly (No. 2 Standard Cut-Off) (26" Table)	
Ref.	050511	Mitre Assembly (No. 2 Standard Cut-Off) (30" Table)	
1	198423	. Screw, Soc. Set 1/4-20NC x 5/16	1
2	201915	. Stop Collar	1
3	198220	. Screw, Soc. Hd. Cap #10-24NC x 1/2	1
4	003682	. Rear Slide Rod Bracket (20" Table)	1
	029583	. Rear Slide Rod Bracket (24", 26", 30" Tables)	1
5	198276	. Screw, Soc. Hd. Cap 3/8-16NC x 1/2 (20", 30" Table)	2
	198278	. Screw, Soc. Hd. Cap 3/8-16NC x 3/4 (24", 26" Table)	2
	34-005414	. Spacer Washer (26" Table Only)	2
6	3-020406	. Slide Rod (20" Table)	1
	4-020401	. Slide Rod (24" Table)	1
	101935	. Slide Rod (26" Table)	1
	101931	. Slide Rod (30" Table)	1
7	198276	. Screw, Soc. Hd. Cap 3/8-16NC x 1/2 (20", 30" Tables)	2
	198278	. Screw, Soc. Hd. Cap 3/8-16NC x 3/4 (24", 26" Tables)	2
	34-005414	. Spacer Washer (26" Table Only)	2
8	003681	. Front Slide Rod Bracket (20" Table)	1
	029584	. Front Slide Rod Bracket (24", 26", 30" Tables)	1
9	198423	. Screw, Soc. Set 1/4-20NC x 5/16	1
10	050710	. Mitre Sub-Assembly (20", 24" Table)	1
	055304	. Mitre Sub-Assembly (26" Table)	1
	050712	. Mitre Sub-Assembly (30" Table)	1
11	34-020410	. . Locking Stud Washer	1
12	003677	. . Stud	1
13	004229	. . Roll Pin	1
14	34-020407	. . Mitre Head Pivot	1
15	34-020409	. . Pivot Washer	1
16	003676	. . Pointer	1
17	199008	. . Screw, Truss Hd. Mach. #8-32NC x 1/4	2
18	004254	. . Roll Pin	2
19	198236	. . Screw, Soc. Hd. Cap 1/4-20NC x 1/2	2
20	4-020302	. . Gauge Rod	1
21	4-020301	. . Mitre Bar (20", 24" Table)	1
	102944	. . Mitre Bar (26" Table)	1
	11-020301	. . Mitre Bar (30" Table)	1
22	003672	. . Degree Plate	1
23	199399	. . Screw, Rd. Hd. Drive #4 x 1/4	4
24	34-017401	. . Thumb Screw	1
25	020941	. . Mitre Head	1
26	005131	. . Handwheel	1
27	040598	. . Slide Arm	1

NEW DRG. S.C.L. 2-25-04
REVISIONS
S.C.L. 2-11-08
S.C.L. 8-3-09

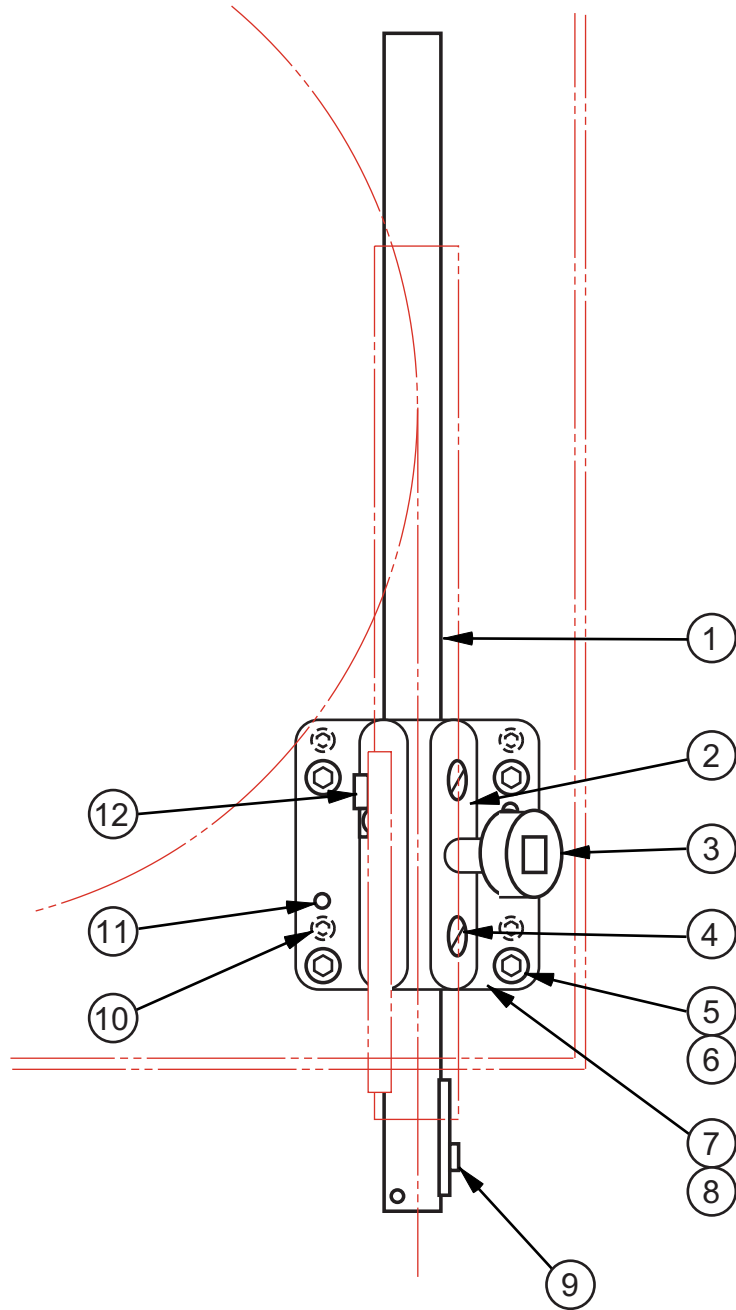

MODEL	FIRST MACH.	LAST MACH.
2013-V	571-04101	
2013-V3	572-04101	
2013-V5	573-04101	
2613-V3	589-09101	

POST ASSEMBLY

C - 2 - 115

POST ASSEMBLY

INDEX NO.	PART NO.	DESCRIPTION	UNITS PER ASS'Y.
Ref.	216836	Post Assembly (Standard)	
Ref.	216837	Post Assembly (19" Work Height)	
Ref.	216938	Post Assembly (25" Work Height)	
Ref.	216839	Post Assembly (31" Work Height)	
1	417400	. Post (21.50") (Standard)	1
	418468	. Post (32.12") (19" Work Height)	1
	418780	. Post (38.12") (25" Work Height)	1
	417630	. Post (44.12") (31" Work Height)	1
2	417394	. Post Slide Casting	1
3	204849	. Lockscrew Sub-Assembly	1
	203548	. . Adaptor	1
	004261	. . Spring Pin	1
	204848	. . Brass Stud	1
4	204850	. Spring Plunger	2
5	198280	. Screw, Soc. Hd. Cap 3/8-16NC x 1-1/4	4
6	199325	. Washer, Lock 3/8 Std.	4
7	319741	. Post Slide Plate	1
8	112328	. Screw, Soc. Hd. Shoulder 5/16-18NC x 1/2	4
9	198698	. Screw, Fill. Hd. Mach. #10-24NC x 1/2	2
10	198459	. Screw, Soc. Set 3/8-24NF x 1	4
11	004282	. Spring Pin	2
12	318807	. Guard Stop Bracket	1

NEW DRG.
S.C.L. 2-25-04
REVISIONS
S.C.L. 8-16-06
S.C.L. 4-4-07
S.C.L. 2-11-08
S.C.L. 9-9-09

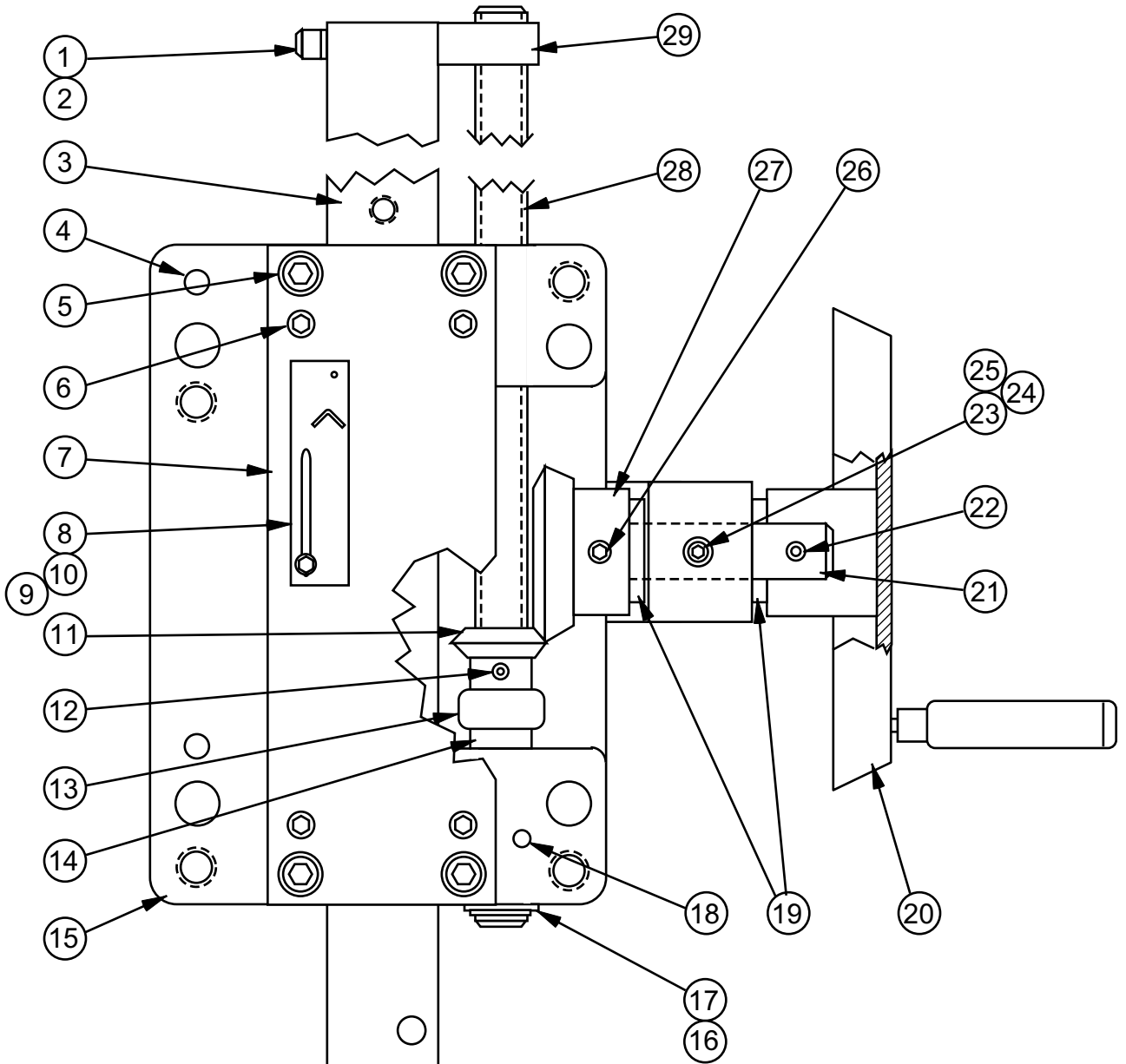

MODEL	FIRST MACH.	LAST MACH.
2012-VH	561-03101	
3613-V3	568-04101	
3613-V5	569-04101	
3612-VH	570-04101	
2013-V	571-04101	
2013-V3	572-04101	
2013-V5	573-04101	
3613-1	577-04101	
2012-D12	584-08101	
2613-V3	589-09101	

POST ELEVATING HANDWHEEL ASSEMBLY

C - 2 - 116 CM - 2 - 130

PRINTED IN U.S.A.

POST ELEVATING HANDWHEEL ASSEMBLY

INDEX NO.	PART NO.	DESCRIPTION	UNITS PER ASS'Y.
Ref.	404971	Post Elevating Handwheel Assembly (Standard)	
Ref.	407860	Post Elevating Handwheel Assembly (18" and 19" Work Heights)	
Ref.	407729	Post Elevating Handwheel Assembly (24" and 25" Work Heights)	
Ref.	407618	Post Elevating Handwheel Assembly (30" and 31" Work Heights)	
1	198245	. Screw, Soc. Hd. Cap 1/4-20NC x 1-1/2	2
2	199374	. Washer, Lock 1/4 Shakeproof	2
3	303029	. Post (25.94") (Standard)	1
	306242	. Post (31.94") (18" and 19" Work Heights)	1
	306243	. Post (37.94") (24" and 25" Work Heights)	1
	306244	. Post (43.94") (30" and 31" Work Heights)	1
4	013122	. Dowel Pin	2
5	198242	. Screw, Soc. Hd. Cap 1/4-20NC x 1	4
6	198576	. Screw, Soc. Set 5/16-18NC x 3/4 (Flat Pt.)	4
7	303030	. Cover	1
8	142425	. Guard Stop Weldment	1
9	198000	. Screw, Hex. Hd. Cap #10-24NC x 3/8	1
10	199258	. Washer, Lock #10 S.A.E. Std.	1
11	125566	. Bevel Gear	1
12	004240	. Spring Pin	1
13	016063	. Thrust Ball Bearing	1
14	133113	. Tubing	1
15	404970	. Housing	1
16	317286	. Retaining Ring	1
17	5-013309	. Spacer	A.R.
18	004263	. Spring Pin	1
19	120922	. Bearing	2
20	216098	. Handwheel	1
21	123901	. Pin	1
22	004259	. Spring Pin	1
23	198422	. Screw, Soc. Set 1/4-20NC x 1/4	1
24	003971	. Compression Spring	1
25	140765	. Friction Plug	1
26	004259	. Spring Pin	1
27	125567	. Bevel Gear	1
28	132667	. Shaft (21.88") (Standard)	1
	143983	. Shaft (27.88") (18" and 19" Work Heights)	1
	143984	. Shaft (33.88") (24" and 25" Work Heights)	1
	143985	. Shaft (39.88") (30" and 31" Work Heights)	1
29	132666	. Nut	1

NEW DRG. S.C.L. 9-18-97
REVISIONS
S.C.L. 2-25-04
S.C.L. 2-11-08

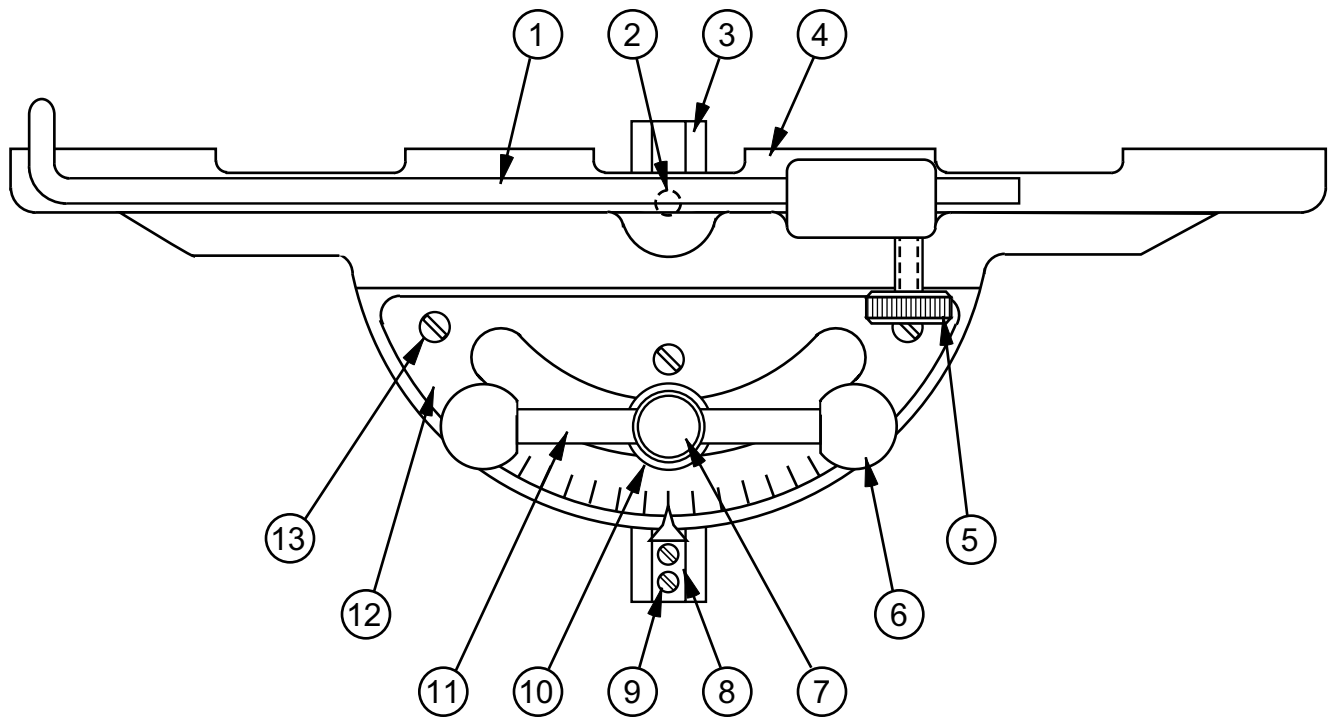

USED ON T-SLOT TABLES.

PROTRACTOR WORK STOP AND ALIGNING GAGE ASSEMBLY

C - 10 - 42 CM - 10 - 7

PRINTED IN U.S.A.

**PROTRACTOR WORK STOP
and
ALIGNMENT GAGE ASSEMBLY**

INDEX NO.	PART NO.	DESCRIPTION	UNITS PER ASS'Y.
Ref.*	051495	Protractor Work Stop And Aligning Gage Assembly	
1	35-001976	. Gage Rod.....	1
2	14-000473	. Dowel Pin	1
3*	025302	. T-Nut	1
4	051496	. Miter Head	1
5	34-017401	. Thumbnut	1
6	133971	. Knob	2
7*	011635	. Stud	1
8	011633	. Pointer	1
9	198867	. Screw, Rd. Hd. Mach. #10-24NC x 3/8.....	2
10	199265	. Washer, Flat 7/16 S.A.E. Std.	1
11	011634	. Shaft	1
12	35-001614	. Protractor Plate	1
13	198867	. Screw, Rd. Hd. Mach. #10-24NC x 3/8	3

*NOTE: For Model 26-HB2

Ref.	054758	Protractor Work Stop And Aligning Gage Assembly	
3	029162	. T-Nut	1
7	101118	. Stud	1

NEW DRG.
S.C.L. 9-19-97
REVISIONS
S.C.L. 2-25-04
S.C.L. 2-11-08

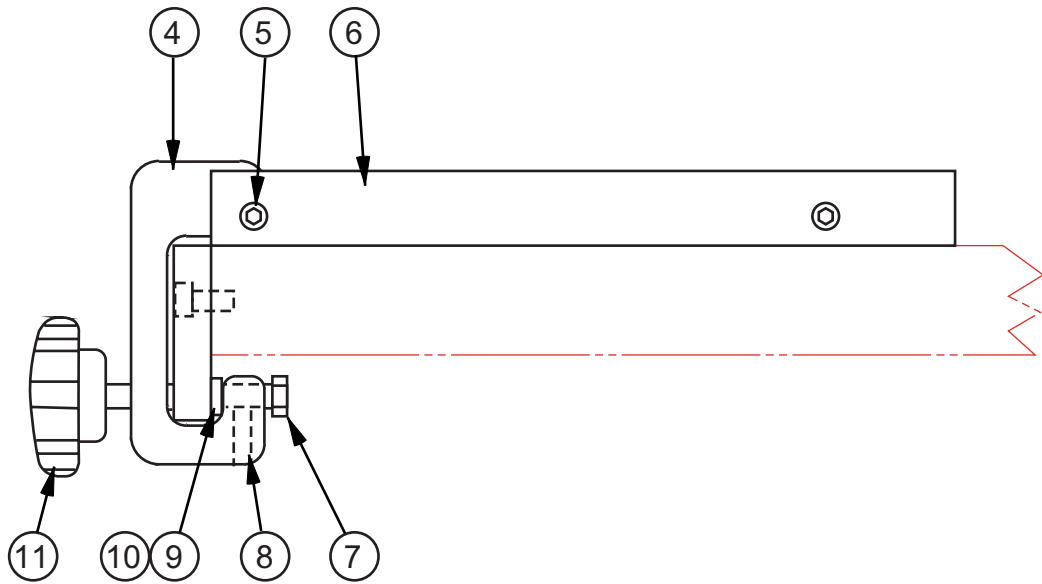
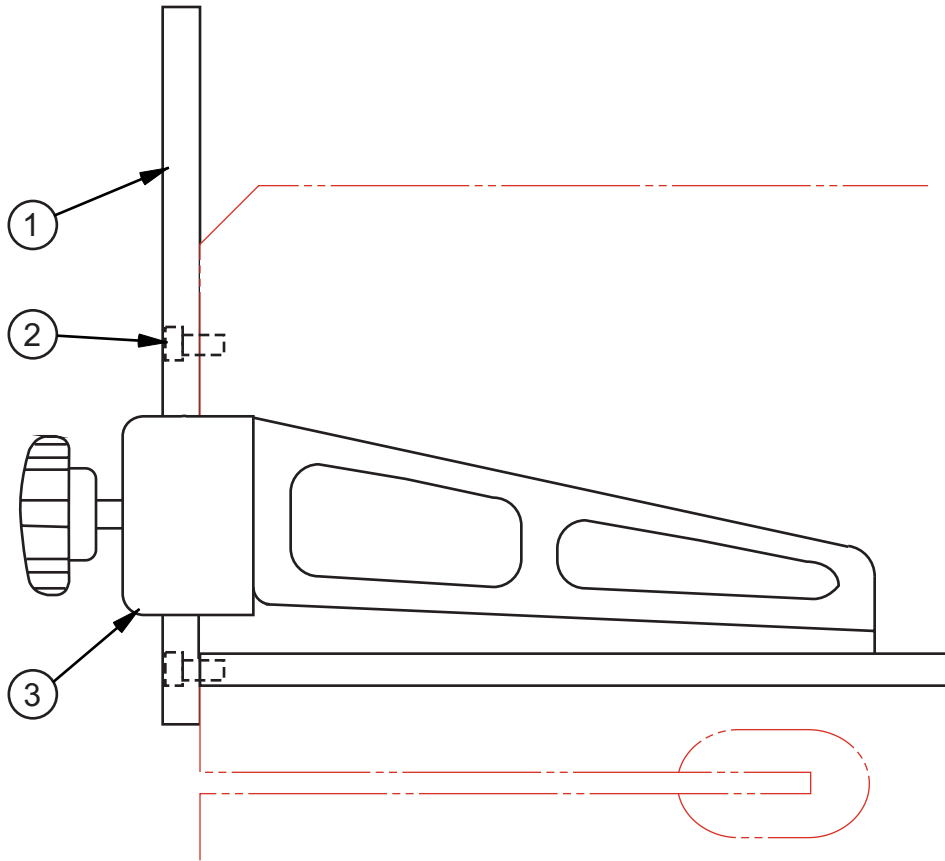

RIP FENCE ASSEMBLY

C - 10 - 6 Z - 9 - 5

PRINTED IN U.S.A.

RIP FENCE ASSEMBLY

INDEX NO.	PART NO.	DESCRIPTION	UNITS PER ASS'Y.
Ref.	35-000543	Rip Fence Assembly (24" Table)	
Ref.	047779	Rip Fence Assembly (26" Table)	
Ref.	35-000542	Rip Fence Assembly (30" Table)	
1	5-016302	. Clamp Guide (24" and 26" Tables)	1
	11-016302	. Clamp Guide (30" Table)	1
2	198278	. Screw, Soc. Hd. Cap 3/8-16NC x 3/4	2
	34-005414	. Spacer Washer (If Supplied)	2
3	35-005251	. Rip Fence Sub-Assembly (24" Table)	1
	35-005178	. Rip Fence Sub-Assembly (26" and 30" Table)	1
4	35-000545	.. Clamp (24" Table)	1
	35-000544	.. Clamp (26" and 30" Tables)	1
5	198278	.. Screw, Soc. Hd. Cap 3/8-16NC x 3/4	2
6	35-000548	.. Work Guide (24" Table)	1
	35-000546	.. Work Guide (26" and 30" Tables)	1
7	5-016403	.. Clamp Bar Screw	2
8	198425	.. Screw, Soc. Set 1/4-20NC x 1/2	2
9	5-016303	.. Clamp Bar	1
10	34-006504	.. Spring Clip	2
11	117670	.. Handwheel Assembly	1
Following Not Shown:			
	203556	. Tag (Rip Fence Alignment)	1

NEW DRG.	S.C.L. 9-25-97
REVISIONS	
S.C.L. 2-20-04	
S.C.L. 2-11-08	

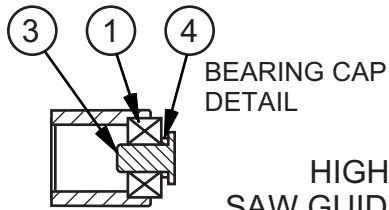

BEARING CAP
DETAIL

HIGH SPEED
SAW GUIDE ASSEMBLY
(CROWNED BANDWHEELS)
(1/16" - 1/2" SAW BANDS)

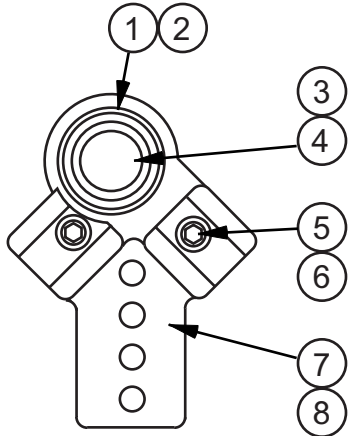

LOWER ASSEMBLY

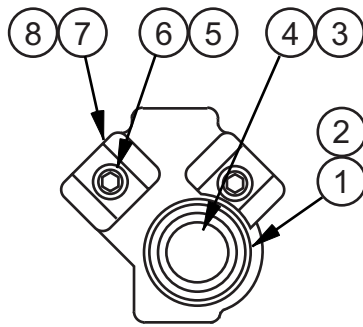

UPPER ASSEMBLY

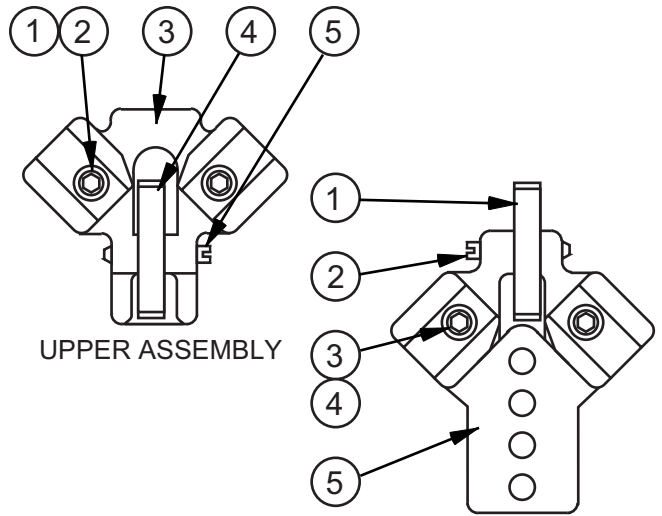

UPPER ASSEMBLY

LOWER ASSEMBLY

SAW GUIDE ASSEMBLY
(FLANGED BANDWHEELS)

STANDARD

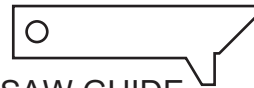

SAW GUIDE
INSERT GAGE

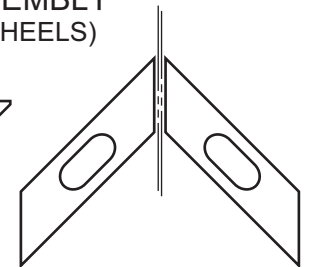

SAW GUIDE INSERTS

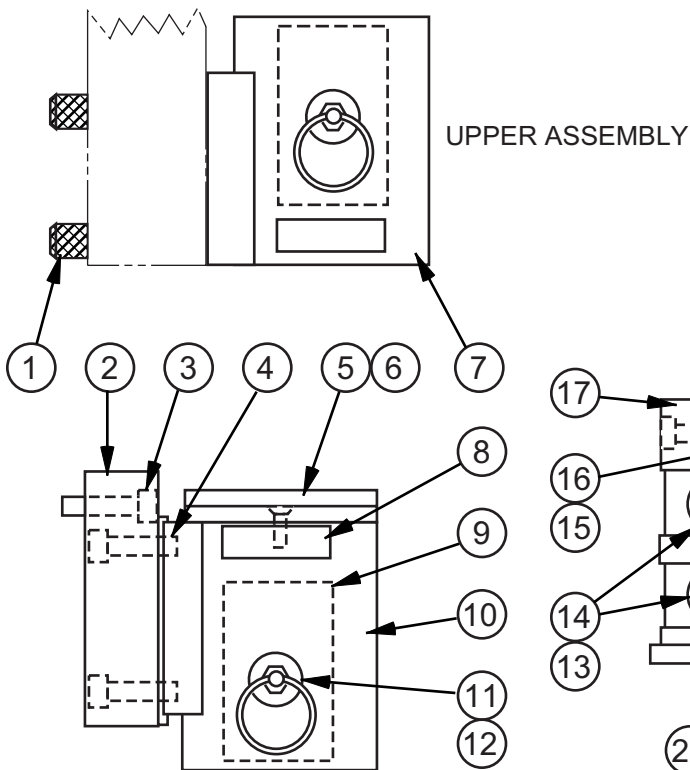

UPPER ASSEMBLY

LOWER ASSEMBLY

ADJUSTABLE ANGLE SAW GUIDE ASSEMBLY

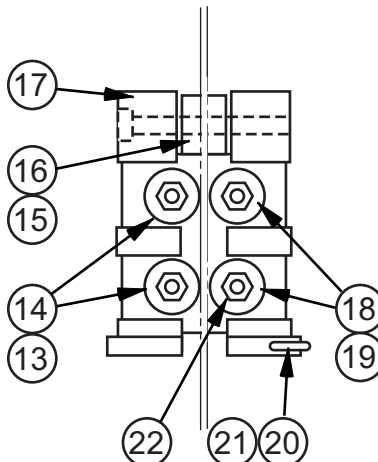

TYPICAL FOR
BOTH GUIDES

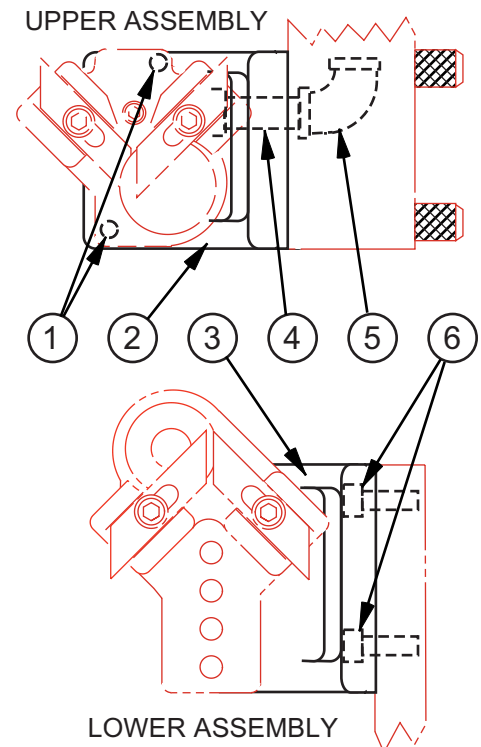

UPPER ASSEMBLY

LOWER ASSEMBLY
90° SAW GUIDE ASSEMBLY

SAW GUIDE ASSEMBLIES
(STANDARD and SPECIAL APPLICATION)

SAW GUIDE ASSEMBLIES

INDEX NO.	PART NO.	DESCRIPTION	UNITS PER ASS'Y.
Ref.	028081	Upper Saw Guide Assembly (High Speed) (1/16"-1/2")	
1*	011529	. Ball Bearing	1
2	011541	. Retaining Ring (If Supplied)	1
3*	018415	. Bearing Cap	1
4*	176845	. Spacer	1
5	198238	. Screw, Soc. Hd. Cap 1/4-20NC x 5/8 ..	2
6	34-008502	. Insert Washer	2
7	027981	. Upper Saw Guide Block	1
8	137339	. Hole Plug (If Supplied)	1

Ref.	028082	Lower Saw Guide Assembly (High Speed) (1/16"-1/2")	
1*	011529	. Ball Bearing	1
2	011541	. Retaining Ring (If Supplied)	1
3*	018415	. Bearing Cap	1
4*	176845	. Spacer	1
5	198238	. Screw, Soc. Hd. Cap 1/4-20NC x 5/8 ...	2
6	34-008502	. Insert Washer	2
7	027983	. Lower Saw Guide Block	1
8	137339	. Hole Plug (If Supplied)	1

*NOTE: When ordering any of the marked items, ordering #085369 - Bearing Replacement Kit is recommended.

STANDARD FOR FLANGE BANDWHEELS

Ref.	304843	Upper Saw Guide Assy (Carbide Insert).	
1	198244	. Screw, Soc. Hd. Cap 1/4-20NC x 1-1/4	2
2	34-008502	. Insert Washer	2
3	406430	. Upper Saw Guide Block	1
4	121210	. Back-Up Insert	1
5	140204	. Pivot Bolt	1

Ref.	304844	Lower Saw Guide Assy (Carbide Insert).	
1	121210	. Back-up Insert	1
2	140204	. Pivot Bolt	1
3	198244	. Screw, Soc. Hd. Cap 1/4-20NC x 1-1/4	2
4	34-008502	. Insert Washer	2
5	406768	. Lower Saw Guide Block	1

90° SAW GUIDE ASSEMBLY

Ref.	416651	90° Saw Guide Assy (26" Table)	
Ref.	044804	90° Saw Guide Assy (30" Table)	
1	198242	. Screw, Soc. Hd. Cap 1/4-20NC x 1	2
2	027597	. 90° Upper Angle Saw Guide Bracket....	1
3	027596	. 90° Lower Angle Saw Guide Bracket....	1
4	011658	. Pipe Nipple	1
5	35-003647	. 90° Elbow	1
6	198239	. Screw, Soc. Hd. Cap 1/4-20NC x 3/4 ..	2
	317853	. Center Plate (Oval) (Not Shown)	1
	029261	. Center Plate (Round)(Not Shown).....	1
	416371	. Chip Baffle (If Supplied) (Not Shown)..	1
	133372	. Thumb Screw (Not Shown)	1

INDEX NO.	PART NO.	DESCRIPTION	UNITS PER ASS'Y.
Ref.	205025	Adjustable Angle Saw Guide Set (26" Table)	
Ref.	205114	Adjustable Angle Saw Guide Set (30" Table)	
1	018500	. Upper Saw Guide Holding Screw	2
2	319704	. Adaptor Bar	1
3	198242	. Screw, Soc. Hd. Cap 1/4-20NC x 1 ..	1
4	198241	. Screw, Soc. Hd. Cap 1/4-20NC x 7/82	
5	205024	. Cap	1
6	198739	. Screw, Flat Hd. Mach. #6-32NC x 3/8	2
7	417525	. Upper Saw Guide Housing	1
8	205818	. Label (Logo)	1
9	205802	. Label (Warning)	1
10	417522	. Lower Saw Guide Housing	1
11	205020	. Spring Plunger	1
12	205399	. Split Ring	1
13	205022	. Roller Bearing	2
14	319979	. Eccentric Stud	2
15	205022	. Roller Bearing	1
16	35-000328	. Dowel Pin	1
17	417524	. Upper Saw Guide	1
	417523	. Lower Saw Guide	1
18	205022	. Roller Bearing	2
19	320173	. Concentric Stud	2
20	205817	. Sleeve Cap	1
21	004219	. Spring Pin	1
22	017655	. Locknut #10-24NC	4

Following Not Shown:

204909	. Gage	1
319939	. Saw Band Guard Assembly	1
319930	. Guard Weldment	1
316934	. Sliding Guard	1
133372	. Thumb Screw	1
317592	. Center Plate (26" Table)	1
120128	. Center Plate (30" Table)	1

SAW GUIDE INSERT GAGE

34-008320	. Insert Gage (.025)	1
13-008303	. Insert Gage (.032)	1
13-009307	. Insert Gage (.035)	1
34-008506	. Box (For Inserts and Gages)	1

SAW GUIDE INSERT SELECTION

<u>STEEL</u>	<u>SIZE</u>	<u>CARBIDE</u>
004499	1/16"	
004498	3/32"	
004497	1/8"	141759
004496	3/16"	
004495	1/4"	016168
003960	3/8"	016170
003959	1/2"	013291
003958	5/8"	105894
003957	3/4"	013292
003956	1"	008982

NEW DRG.
S.C.L. 9-29-97
REVISIONS
S.C.L. 2-20-04
S.C.L. 2-11-08

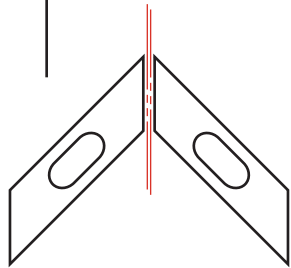

SAW GUIDE INSERTS

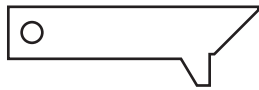

SAW GUIDE INSERT GAGE

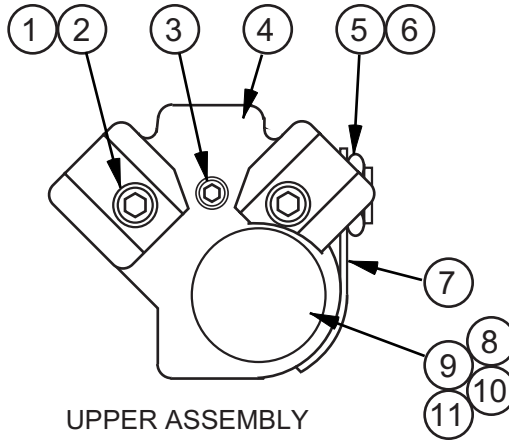

UPPER ASSEMBLY

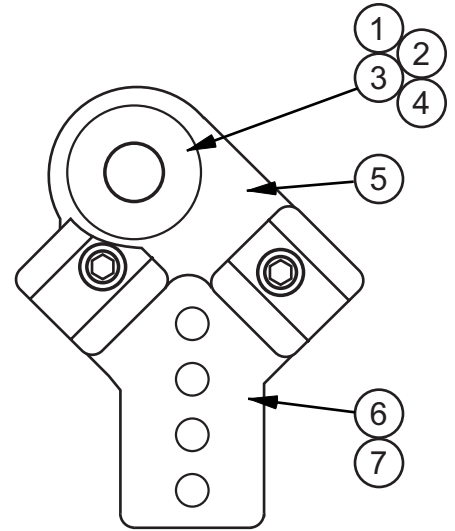

LOWER ASSEMBLY

HEAVY DUTY SAW GUIDE ASSEMBLY
(WITH CARBIDE BACK-UP)

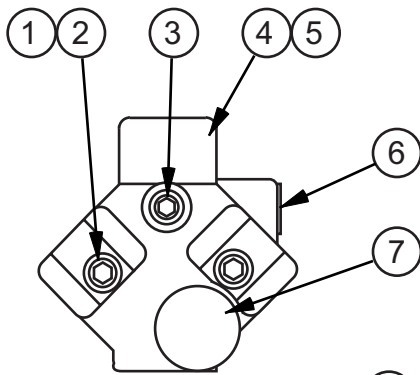

UPPER ASSEMBLY

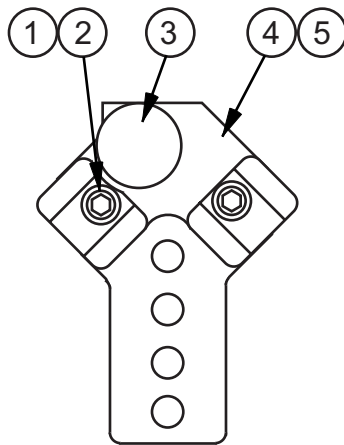

LOWER ASSEMBLY

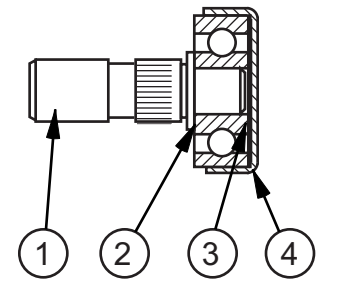

BEARING SUB-ASSEMBLY

PRECISION SAW GUIDE ASSEMBLY
(1/16" - 1/2" SAW BANDS)

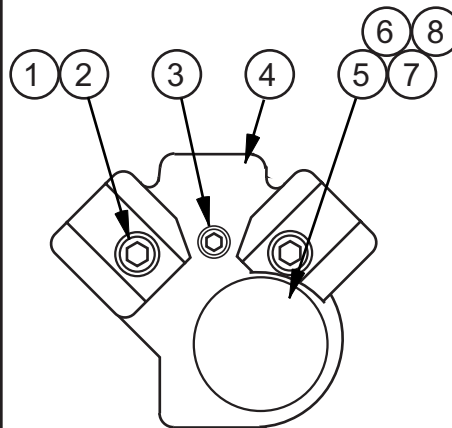

UPPER ASSEMBLY

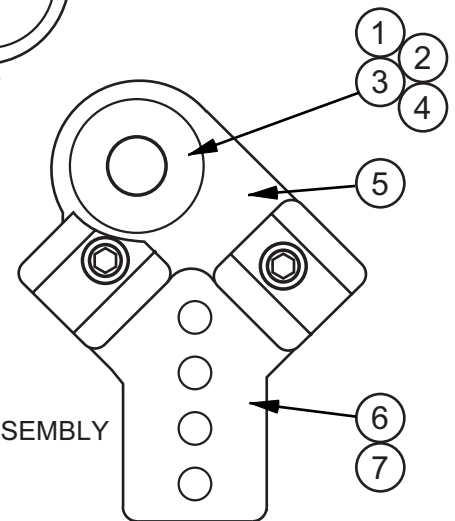

LOWER ASSEMBLY

HEAVY DUTY SAW GUIDE ASSEMBLY
(WITH STEEL BACK-UP)

SAW GUIDE ASSEMBLIES (INSERT TYPE)

C - 7 - 18 CM - 7 - 23

PRINTED IN U.S.A.

NEW DRG.
S.C.L. 9-30-97
REVISIONS
S.C.L. 2-20-04
S.C.L. 2-11-08

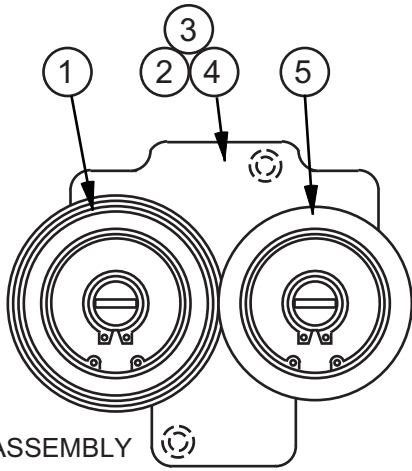

UPPER ASSEMBLY

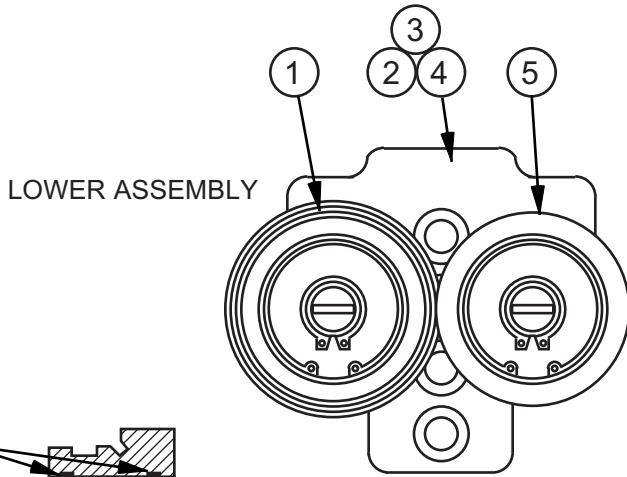

LOWER ASSEMBLY

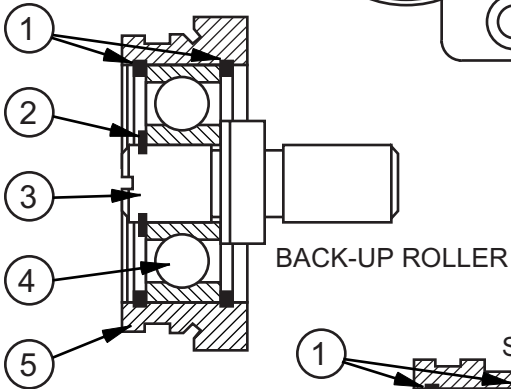

BACK-UP ROLLER

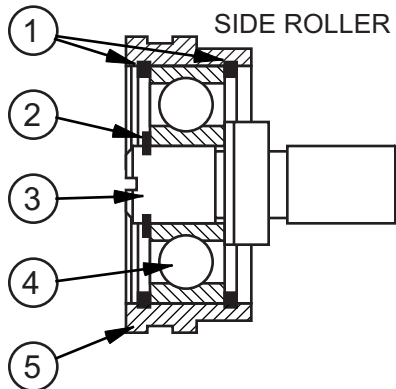

SIDE ROLLER

TYPE I - ROLLER SAW GUIDE ASSEMBLY

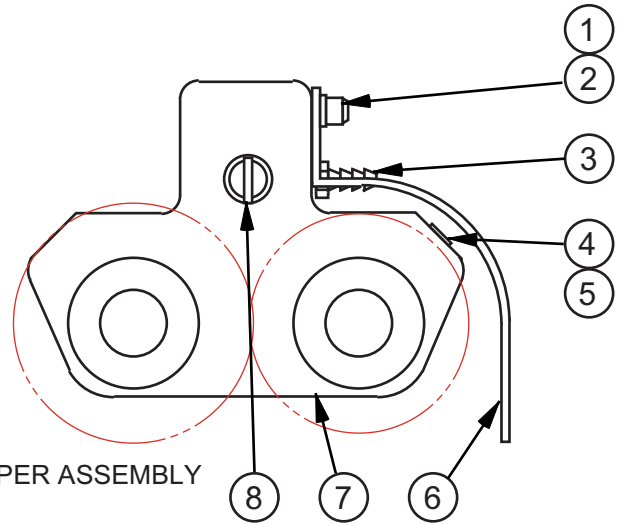

UPPER ASSEMBLY

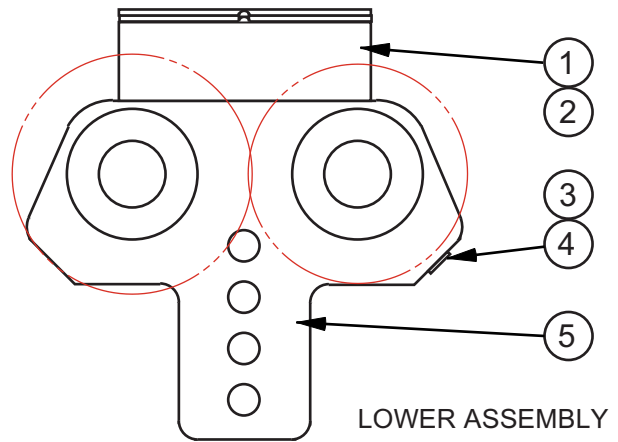

LOWER ASSEMBLY

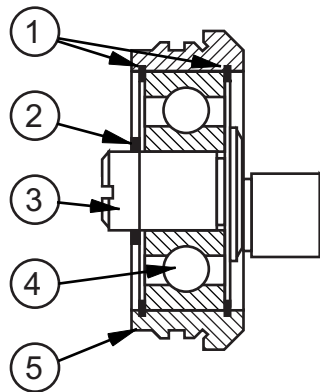

BACK-UP ROLLER

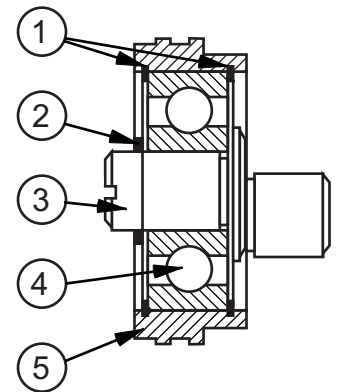

SIDE ROLLER

TYPE II - ROLLER SAW GUIDE ASSEMBLY

SAW GUIDE ASSEMBLIES (ROLLER TYPE)

SAW GUIDE ASSEMBLIES

INDEX NO.	PART NO.	DESCRIPTION	UNITS PER ASS'Y.	INDEX NO.	PART NO.	DESCRIPTION	UNITS PER ASS'Y.
<u>TYPE I – ROLLER SAW GUIDE ASSEMBLY</u>				<u>TYPE II ROLLER ASSEMBLIES</u>			
Ref.	029256	1/4" Upper Roller Saw Guide Assembly		Ref.	020798	1/4" Back-Up Roller Assembly	
Ref.	029258	3/8" Upper Roller Saw Guide Assembly		Ref.	020808	3/8" Back-Up Roller Assembly	
Ref.	029506	1/2" Upper Roller Saw Guide Assembly		Ref.	020295	1/2" Back-Up Roller Assembly	
1	See Below	. Back-Up Roller Assy (See Detail)	1	Ref.	021071	5/8" Back-Up Roller Assembly	
2	028960	. Upper Guide Block	1	Ref.	020296	3/4" Back-Up Roller Assembly	
3	198239	. Screw, Soc. Hd. Cap 1/4-20NC x 3/4 ..	2	Ref.*	028968	1" Back-Up Roller Assembly	
4	199321	. Washer, Lock 1/4 Std.	2	1	001303	. Retaining Ring	2
5	See Below	. Side Roller Assy (See Detail)	1	2	001568	. Retaining Ring	1
Ref.	029257	1/4" Lower Roller Saw Guide Assembly		3	013530	. Spindle	1
Ref.	029259	3/8" Lower Roller Saw Guide Assembly		4	001779	. Ball Bearing	2
Ref.	029505	1/2" Lower Roller Saw Guide Assembly		5	013532	. 1/4" Back-Up Roller	1
1	See Below	. Back-Up Roller Assy (See Detail)	1	Ref.	013541	. 3/8" Back-Up Roller	1
2	028961	. Lower Guide Block	1	013534	. 1/2" Back-Up Roller	1	
3	199239	. Screw, Soc. Hd. Cap 1/4-20NC x 3/4 ..	2	013543	. 5/8" Back-Up Roller	1	
4	199321	. Washer, Lock 1/4 Std.	2	013536	. 3/4" Back-Up Roller	1	
5	See Below	. Side Roller Assy (See Detail)	1	100757	. 1" Back-Up Roller	1	
<u>TYPE I – ROLLER ASSEMBLIES</u>				Ref.	020799	1/4" Side Roller Assembly	
Ref.	028982	1/4" Back-Up Roller Assembly		Ref.	020807	3/8" Side Roller Assembly	
Ref.	028978	3/8" Back-Up Roller Assembly		Ref.	020292	1/2" Side Roller Assembly	
Ref.	028976	1/2" Back-Up Roller Assembly		Ref.	021072	5/8" Side Roller Assembly	
1	100046	. Retaining Ring	2	Ref.	020293	3/4" Side Roller Assembly	
2	011541	. Retaining Ring	1	Ref.*	028967	1" Side Roller Assembly	
3	018296	. Shaft	1	1	001303	. Retaining Ring	2
4	011529	. Ball Bearing	2	2	001568	. Retaining Ring	1
5	028983	. 1/4" Back-up Roller	1	3	013530	. Spindle	1
	028979	. 3/8" Back-up Roller	1	4	001779	. Ball Bearing	2
	028977	. 1/2" Back-up Roller	1	5	013531	. 1/4" Side Roller	1
Ref.	028984	1/4" Side Roller Assembly			013540	. 3/8" Side Roller	1
Ref.	028980	3/8" Side Roller Assembly			013533	. 1/2" Side Roller	1
Ref.	028974	1/2" Side Roller Assembly			013542	. 5/8" Side Roller	1
1	100046	. Retaining Ring	2		013535	. 3/4" Side Roller	1
2	011541	. Retaining Ring	1		100758	. 1" Side Roller	1
3	018296	. Shaft	1	*NOTE: To Be Used With Flanged Rubber-Tired Wheels Using 1/4", 1/2", 3/4" or 1" Bands. Also Used With Steel Fanged or Rubber Crowned Wheels Using 1" Band Only.			
4	011529	. Ball Bearing	2				
5	028985	. 1/4" Side Roller	1				
	028981	. 3/8" Side Roller	1				
	028975	. 1/2" Side Roller	1				
<u>TYPE II – ROLLER SAW GUIDE ASSEMBLY</u>							
Ref.	109517	Upper Saw Guide Block Assembly					
1	198236	. Screw, Soc. Hd. Cap 1/4-20NC x 1/2 ..	1				
2	199321	. Washer, Lock 1/4 Std.	1				
3	016001	. Barbed Insert	1				
4	198448	. Screw, Soc. Set 3/8-16NC x 3/8	2				
5	001741	. Plug	2				
6	033636	. Coolant Guard	1				
7	033517	. Upper Saw Guide Block	1				
8	033509	. Coolant Nozzle	1				
Ref.	017215	Lower Saw Guide Block Assembly					
1	002140	. Chip Deflector	1				
2	198235	. Screw, Soc. Hd. Cap 1/4-20NC x 3/8 ..	2				
3	198449	. Screw, Soc. Set 3/8-16NC x 1/2	2				
4	001741	. Plug	2				
5	027743	. Lower Saw Guide Block	1				
Not Shown (For Both Upper and Lower Guides):							
	131798	. Cloth Bag	1				

NEW DRG.	S.C.L. 2-25-04
REVISIONS	
S.C.L. 2-12-08	
S.C.L. 8-3-09	

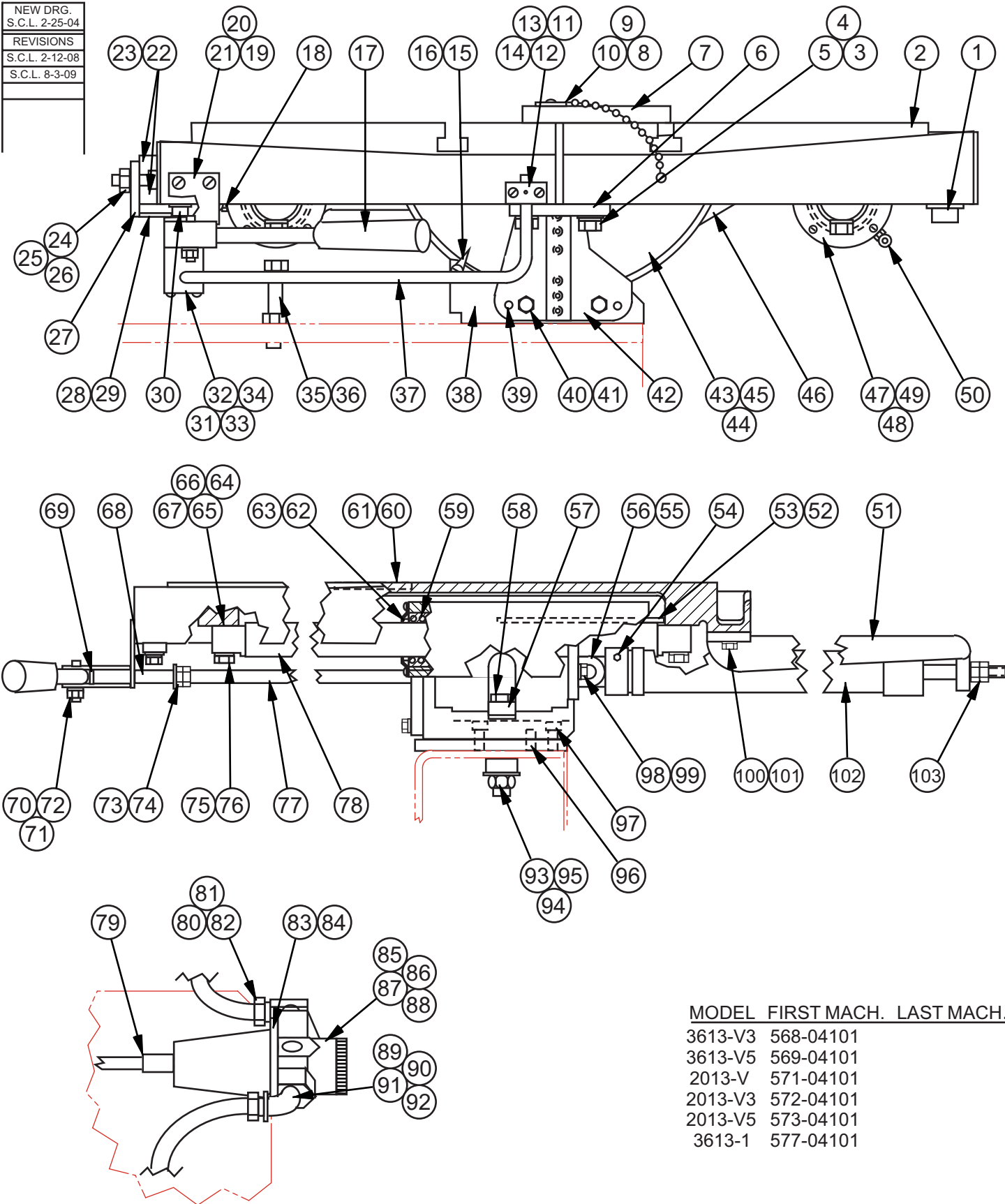

SLIDING AIR TABLE ASSEMBLY

SLIDING AIR TABLE ASSEMBLY

INDEX NO.	PART NO.	DESCRIPTION	UNITS PER ASS'Y.	INDEX NO.	PART NO.	DESCRIPTION	UNITS PER ASS'Y.
Ref.	503826	Sliding Air Table Assembly		53	199019	. Screw, Truss Hd. Mach. 1/4-20NC x 3/8	6
Ref.	211092	Sliding Air Table Assembly (18" Stroke Option)		54	11-005509	. Pipe Plug	1
1	35-006580	. Pipe Plug	1	55	021594	. Swivel Base	1
2	501380	. Table	1	56	005130	. Pin	1
	518044	. Table (18" Stroke Option)	1	57	039464	. Head	1
3	198047	. Screw, Hex. Hd. Cap 3/8-16NC x 1-1/4	2	58	198106	. Screw, Hex. Hd. Cap 3/4-16NF x 5	1
4	199325	. Washer, Lock 3/8 Std.	2	59	003647	. Ball Bushing	4
5	199264	. Washer, Flat 3/8 S.A.E. Std.	2	60	010490	. Center Plate	1
6	004599	. Clamp	1	61	004209	. Spring Pin	1
7	125361	. Square Weldment	1	62	165507	. Rod Wiper	4
8	129590	. Chain	1	63	260468	. O-Ring	4
9	198851	. Screw, Rd. Hd. Mach. #8-32NC x 1/4 ..	2	64	133310	. Shim (.035)	A.R.
10	125393	. Plug	1	65	133311	. Shim (.0149)	A.R.
11	135730	. Support Block	1	66	133312	. Shim (.005)	A.R.
12	198847	. Screw, Rd. Hd. Mach. #6-32NC x 1-1/4	2	67	133313	. Shim (.003)	A.R.
13	199317	. Washer, Lock #6 Std.	2	68	172730	. Shaft	1
14	198406	. Screw, Soc. Set #6-32NC x 1/4	1	69	004244	. Spring Pin	1
15	34-003315	. Pointer	1	70	198252	. Screw, Soc. Hd. Cap 1/4-28NF x 1-1/4	1
16	198838	. Screw, Rd. Hd. Mach. #6-32NC x 1/4 ..	2	71	115660	. Locknut 1/4-28NF (Slotted)	1
17	131011	. Handle Sub-Assembly	1	72	104632	. Belleville Washer	6
	118116	. Handle	1	73	199127	. Nut, Hex. Jam 3/8-16NC	1
	004242	. Spring Pin	1	74	199358	. Washer, Lock 3/8 Shakeproof	1
	125392	. Shaft	1	75	198069	. Screw, Hex. Hd. Cap 1/2-13NC x 2	4
18	35-001775	. Grease Fitting	1	76	199327	. Washer, Lock 1/2 Std.	4
19	125389	. Bracket Weldment	1	77	203103	. Actuator Rod	1
20	198895	. Screw, Rd. Hd. Mach. 1/4-20NC x 1/2 ..	2	211086	. Actuator Rod (18" Stroke Option)	1	
21	199356	. Washer, Lock 1/4 Shakeproof	2	78	021612	. Guide Rod	1
22	023967	. Slide Bar	1	321738	. Guide Rod (18" Stroke Option)	1	
	321369	. Slide Bar (18" Stroke Option)	1	79	199356	. Washer, Lock 1/4 Shakeproof	1
23	198221	. Screw, Soc. Hd. Cap #10-24NC x 5/8 ..	10	80	197094	. Neoprene Hose 11/16 O.D. (Black)	A.R.
24	009392	. T-Bolt 5/16-18NC	2	81	002004	. Barbed Insert	2
25	199122	. Nut, Hex. 5/16-18NC	2	82	35-006888	. Hose Clamp	2
26	198218	. Screw, Soc. Hd. Cap #10-24NC x 1/4 ..	2	83	125386	. Mounting Plate	1
27	009504	. Dog	2	84	198678	. Screw, Fil. Hd. Mach. 1/4-24NF x 1-1/4	2
28	009503	. Stop	2	85	125674	. Regulating Valve	1
29	198895	. Screw, Rd. Hd. Mach. 1/4-20NC x 1/2 ..	2	86	198009	. Screw, Hex. Hd. Cap 1/4-20NC x 7/8 ..	2
30	6-033518	. Pipe Plug	1	87	199356	. Washer, Lock 1/4 Shakeproof	2
31	135741	. Support Bar	1	88	122748	. Pipe Plug	1
32	198850	. Screw, Rd. Hd. Mach. #6-32NC x 1-3/4	2	89	17-013521	. 90° Street Elbow	1
33	199317	. Washer, Lock #6 Std.	2	90	002004	. Barbed Insert	2
34	198406	. Screw, Soc. Set #6-32NC x 1/4	1	91	35-006888	. Hose Clamp	2
35	198053	. Screw, Hex. Hd. Cap 3/8-16NC x 2-3/4	1	92	197094	. Neoprene Hose 11/16 O.D. (Black)	A.R.
36	199127	. Nut, Hex. Jam 3/8-16NC	1	93	199141	. Nut, Hex. Jam 3/4-16NF	1
37	303601	. Guard Bar	1	94	199268	. Washer, Flat 3/4 S.A.E. Std.	1
38	040903	. Cradle	1	95	010501	. Spacer	1
39	133875	. Dowel Pin	2	96	016351	. Dowel Pin (1" Long)	1
40	198047	. Screw, Hex. Hd. Cap 3/8-16NC x 1-1/4	2	35-000445	. Dowel Pin (1-1/2" Long)	1	
41	199325	. Washer, Lock 3/8 Std.	2	97	198291	. Screw, Soc. Hd. Cap 1/2-13NC x 3/4 ...	4
42	024241	. Keeper Block	1	98	198027	. Screw, Hex. Hd. Cap 5/16-18NC x 3/4	2
43	021621	. Trunnion Plate	1	99	199323	. Washer, Lock 5/16 Std.	2
44	198822	. Screw, Rd. Hd. Mach. 1/4-20NC x 3/8 ..	2	100	198044	. Screw, Hex. Hd. Cap 3/8-16NC x 3/4 ..	2
45	199356	. Washer, Lock 1/4 Shakeproof	2	101	199325	. Washer, Lock 3/8 Std.	2
46	050791	. Trunnion	1	102	209718	. Table Feed Cylinder	1
47	005176	. Retainer	4	209867	. Table Feed Cylinder (18" Stroke Option)	1	
48	198867	. Screw, Rd. Hd. Mach. #10-24NC x 3/8.	16	199134	. Nut, Hex. Jam 1/2-20NF	2	
49	199319	. Washer, Lock #10 Std.	16		Following Not Shown:		
50	010656	. 45° Grease Fitting	1	204231	. Adjustment/Installation Summary	1	
51	041061	. Cylinder Bracket	1	35-004455	. Reducer Bushing	1	
	418499	. Cylinder Bracket Weldment (18" Stroke Option)	11	203809	. Flow Control Valve (Right Angle)	1	
52	503045	. Pan	1	176811	. Vent Filter Breather	1	
	518292	. Pan Assembly (18" Stroke Option)	1	203271	. Grommet	3	
	418785	. Sliding Pan	1				
	321752	. Pan Weldment	1				

NEW DRG. S.C.L. 2-25-04
REVISIONS
S.C.L. 2-12-08

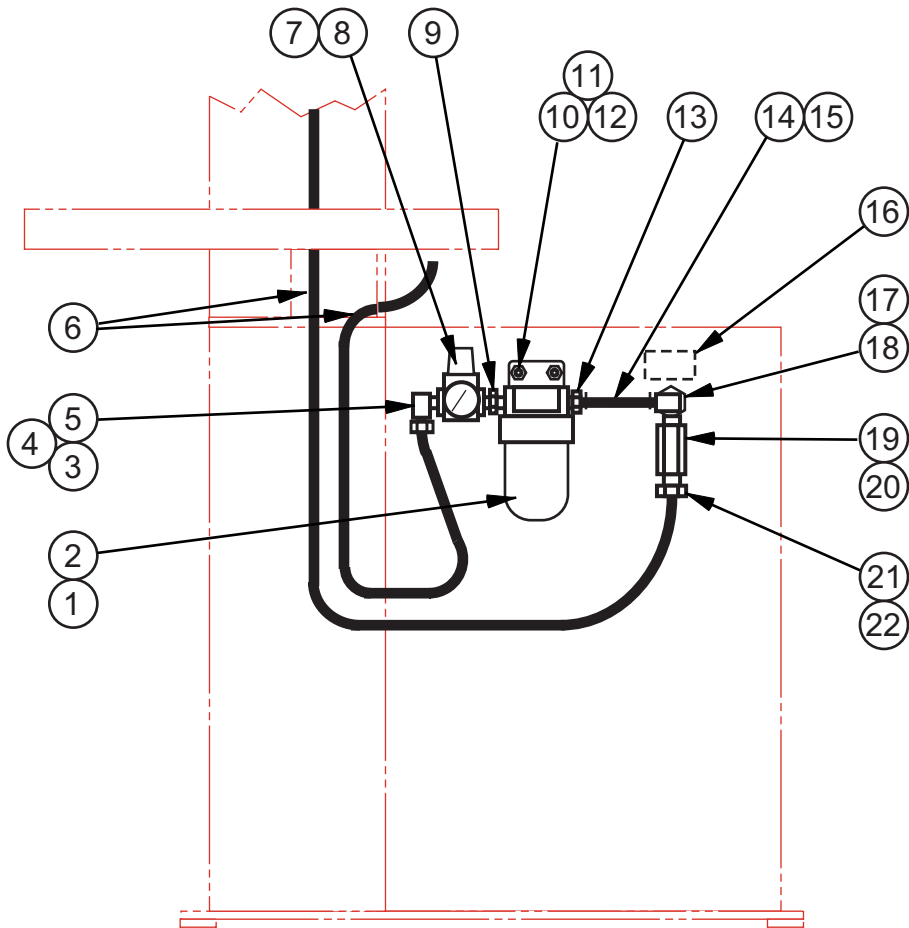

MODEL	FIRST MACH.	LAST MACH.
3613-V3	568-04101	
3613-V5	569-04101	
2013-V	571-04101	
2013-V3	572-04101	
2013-V5	573-04101	
3613-1	577-04101	

SLIDING AIR TABLE ASSEMBLY (SHOP AIR CONNECTION)

SLIDING AIR TABLE ASSEMBLY
(Shop Air Connection)

INDEX NO.	PART NO.	DESCRIPTION	UNITS PER ASS'Y.
Ref.	208124	Sliding Air Table Assembly (Shop Air Connection)	
1	145883	. Oil-Fog Lubricator (Includes Bracket)	1
2	138445	. Oil (ASTM #315)	A.R.
3	197094	. Neoprene Hose 11/16 O.D. (Black)	A.R.
4	5-027506	. 90° Street Elbow	1
5	128179	. Barbed Insert	1
6	35-006888	. Hose Clamp	1
7	206114	. Regulator	1
8	206137	. Gauge	1
9	010923	. Hex. Nipple	1
10	198896	. Screw, Rd. Hd. Mach. 1/4-20NC x 5/8	2
11	199115	. Nut, Hex. 1/4-20NC	2
12	199374	. Washer, Lock 1/4 Shakeproof	2
13	002004	. Barbed Insert	1
14	197094	. Neoprene Hose 11/16 O.D. (Black)	A.R.
15	35-006888	. Hose Clamp	2
16	176879	. Escutcheon (Air Supply)	1
17	203818	. Anchor Connector	1
18	120389	. 90° Barbed Insert	1
*	120857	. Service Tee (Brass)	1
19*	002004	. Barbed Insert	1
20*	35-006888	. Hose Clamp	1
21*	197094	. Neoprene Hose 11/16 O.D. (Black)	A.R.
22*	35-006888	. Hose Clamp	2

*When Chip Blower or Mist Coolant Options Are Supplied.

NEW DRG. S.C.L. 2-25-04
REVISIONS
S.C.L. 2-12-08
S.C.L. 9-9-09

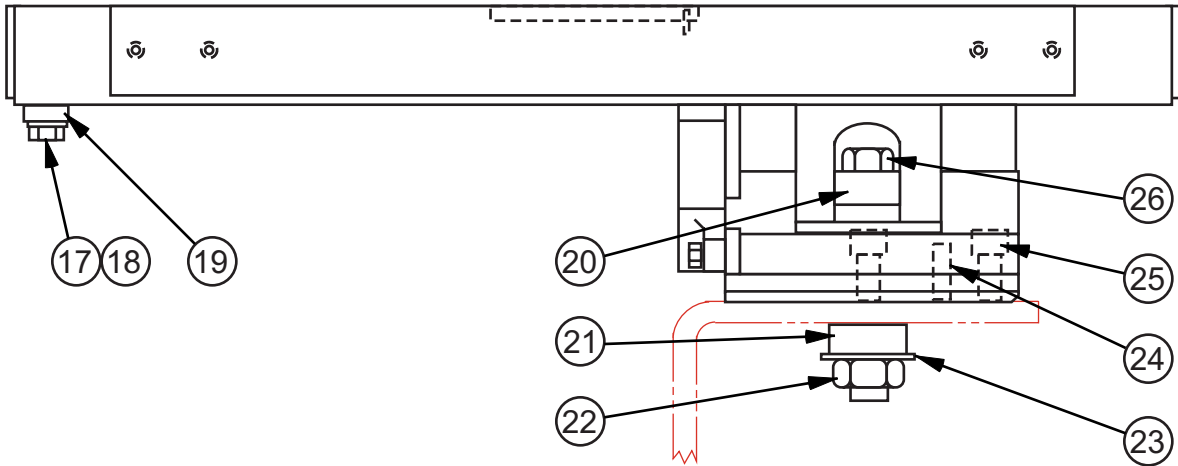
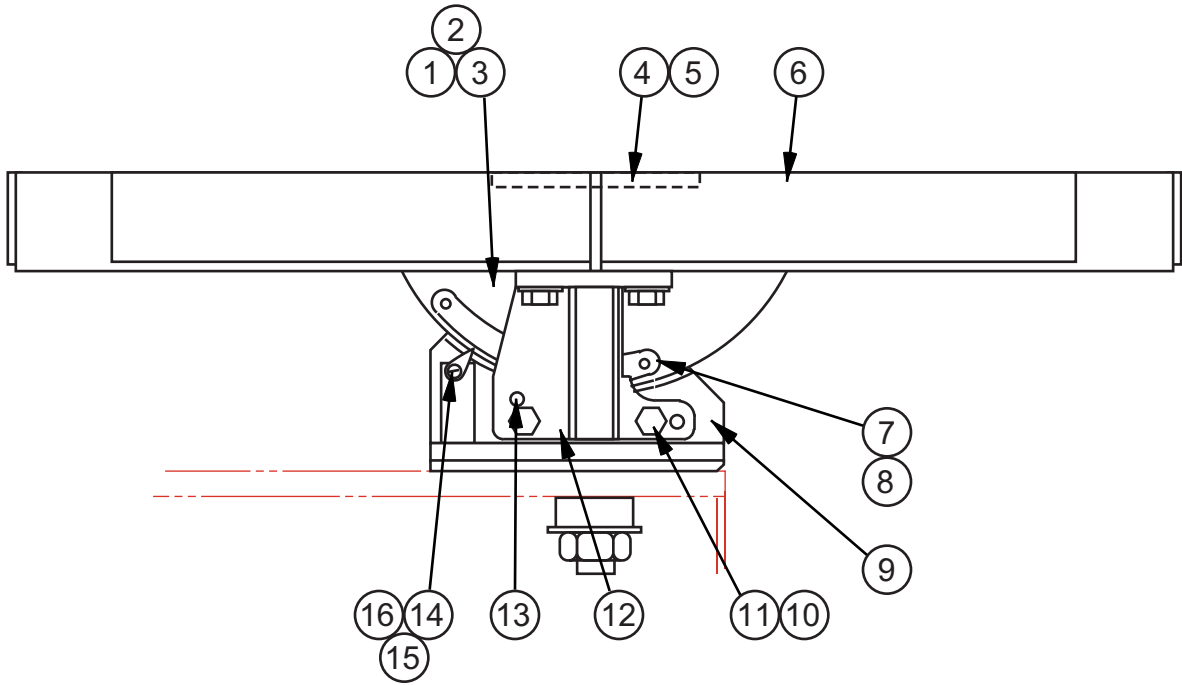

MODEL	FIRST MACH.	LAST MACH.
3613-V3	568-04101	
3613-V5	569-04101	
2013-V	571-04101	
2013-V3	572-04101	
2013-V5	573-04101	
3613-1	577-04101	
2613-V3	589-09101	

TABLE AND TRUNNION ASSEMBLY

TABLE AND TRUNNION ASSEMBLY

INDEX NO.	PART NO.	DESCRIPTION	UNITS PER ASS'Y.
Ref.	172512	Table and Trunnion Assembly (26" x 26")	
Ref.	172513	Table and Trunnion Assembly (30" x 30")	
1	040645	. Trunnion	1
2	198065	. Screw, Hex. Hd. Cap 1/2-13NC x 1	4
3	199327	. Washer, Lock 1/2 Std.	4
4	316903	. Center Plate (Oval) (Standard)	1
	010490	. Center Plate (Round) (Standard)	1
	317592	. Center Plate (Oval) (Band Filing, Angle Saw Guide Set Option)	1
	120128	. Center Plate (Round) (Band Filing, Angle Saw Guide Set Option)	1
	318034	. Center Plate (Oval) (Band Polishing Option)	1
	010570	. Center Plate (Round) (Band Polishing Option)	1
	317853	. Center Plate (Oval) (90° Saw Guide Option)	1
	029261	. Center Plate (Round) (90° Saw Guide Option)	1
5	004209	. Spring Pin (Round Center Plate Only)	1
6	514113	. Table (26" x 26") (Oval Center Plate)	1
	055303	. Table (26" x 26") (Round Center Plate)	1
	059826	. Table (30" x 30")	1
7	003861	. Escutcheon	1
8	199401	. Screw, Rd. Hd. Drive #6 x 3/8	2
9	512731	. Cradle	1
10	198046	. Screw, Hex. Hd. Cap 3/8-16NC x 1	2
11	199325	. Washer, Lock 3/8 Std.	2
12	024244	. Lower Post Block	1
13	35-000516	. Dowel Pin	2
14	34-003315	. Pointer	1
15	198839	. Screw, Rd. Hd. Mach. #6-32NC x 5/16	1
16	199273	. Washer, Flat #6 S.A.E. Std.	2
17	198046	. Screw, Hex. Hd. Cap 3/8-16NC x 1	2
18	199264	. Washer, Flat 3/8 S.A.E. Std.	2
19	004599	. Clamp	1
20	039464	. Head	1
21	010501	. Spacer	1
22	199141	. Nut, Hex. 3/4-16NF	1
23	199268	. Washer, Flat 3/4 S.A.E. Std.	1
24	016351	. Dowel Pin	2
25	198291	. Screw, Soc. Hd. Cap 1/2-3NC x 3/4	3
26	198106	. Screw, Hex. Hd. Cap 3/4-16NF x 5	1

NEW DRG.
S.C.L. 9-18-97
REVISIONS
S.C.L. 2-25-04
S.C.L. 2-12-08

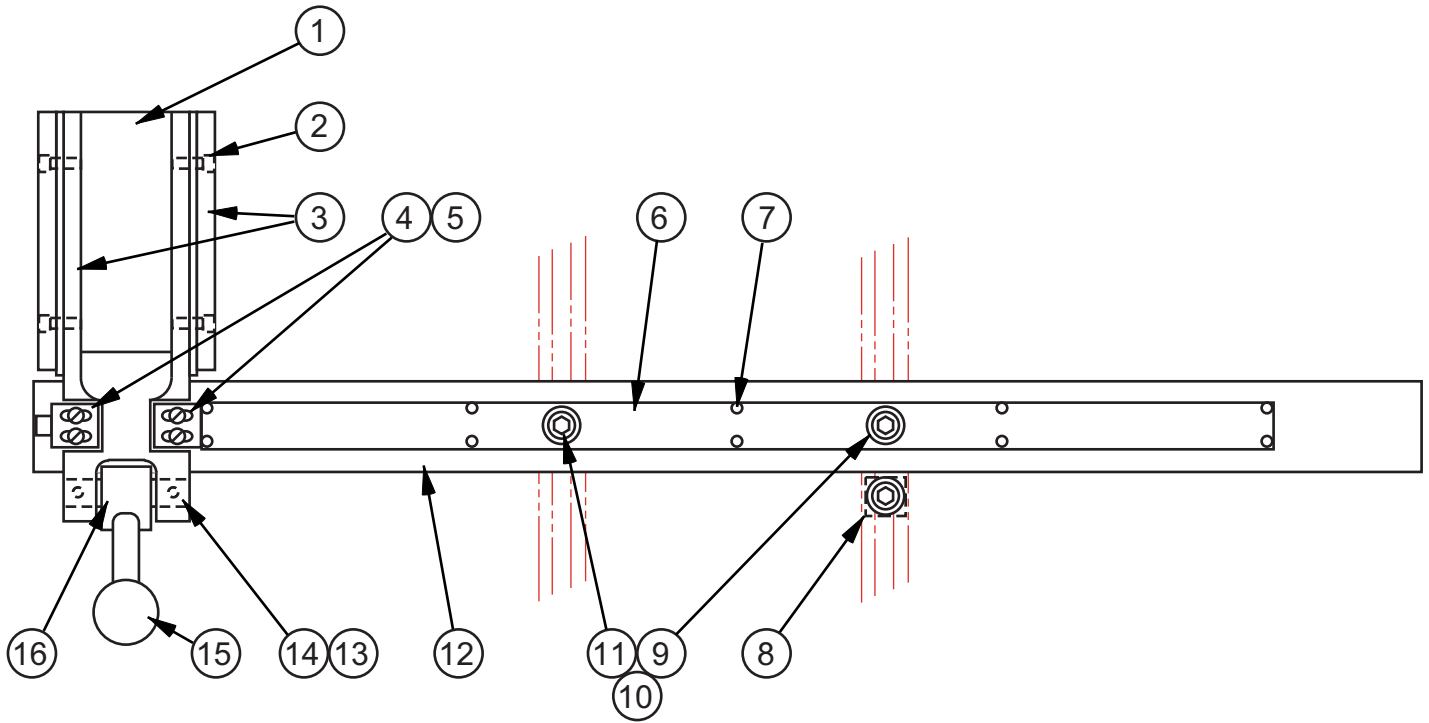

USED ON T-SLOT TABLES.

UNIVERSALLY CALIBRATED WORK FIXTURE ASSEMBLY

C - 10 - 43 CM - 10 - 9

PRINTED IN U.S.A.

UNIVERSALLY CALIBRATED WORK FIXTURE ASSEMBLY

INDEX NO.	PART NO.	DESCRIPTION	UNITS PER ASS'Y.
Ref.	045083	Universally Calibrated Work Fixture Assembly (11" Scale)	
Ref.	404907	Universally Calibrated Work Fixture Assembly (28 cm Scale)	
Ref.	045084	Universally Calibrated Work Fixture Assembly (16" Scale)	
Ref.	404817	Universally Calibrated Work Fixture Assembly (41 cm Scale)	
1	045085	. Head	1
2	198236	. Screw, Soc. Hd. Cap 1/4-20NC x 1/2	4
3	018390	. Wear Strip	2
4	018392	. Pointer	2
5	199005	. Screw, Truss Hd. Mach. #6-32NC x 1/4	4
6	045088	. Scale (11" - 0" - 11")	1
	047500	. Scale (28cm - 0cm - 28cm)	1
	045089	. Scale (16" - 0" - 16")	1
	047499	. Scale (41cm - 0cm - 41cm)	1
7	198833	. Screw, Rd. Hd. Mach. #5-40NC x 1/8	10
8	101117	. Collar (For Angle Cutting)	1
9	198281	. Screw, Soc. Hd. Cap 3/8-16NC x 1-1/2	2
10	199264	. Washer, Flat 3/8 S.A.E. Std.	2
11	003855	. T-Slot Nut	2
12	045086	. Bar (11" and 28 cm Scales)	1
	045087	. Bar (16" and 41 cm Scales)	1
13	018391	. Pin	1
14	198417	. Screw, Soc. Set #10-32NF x 1/4	2
15	34-013508	. Knob	1
16	028892	. Cam Assembly	1
	100702	. . Cam	1
	002579	. . Handle	1

NEW DRG.
S.C.L. 9-18-97
REVISIONS
S.C.L. 2-25-04
S.C.L. 2-12-08

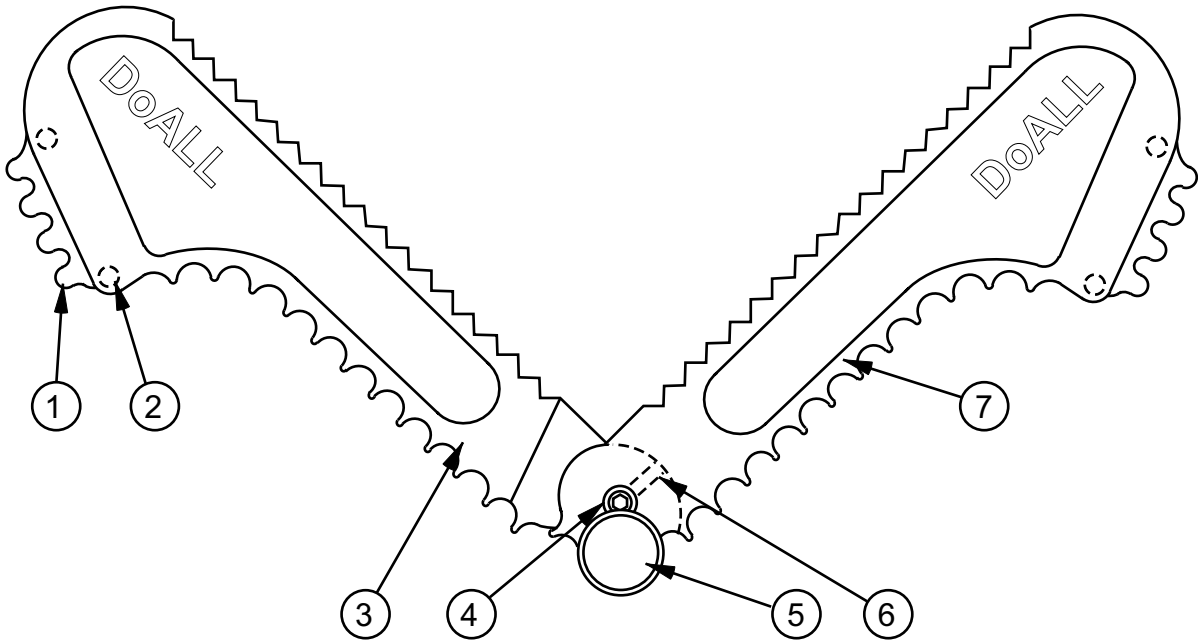

WORK HOLDER ASSEMBLY
040262

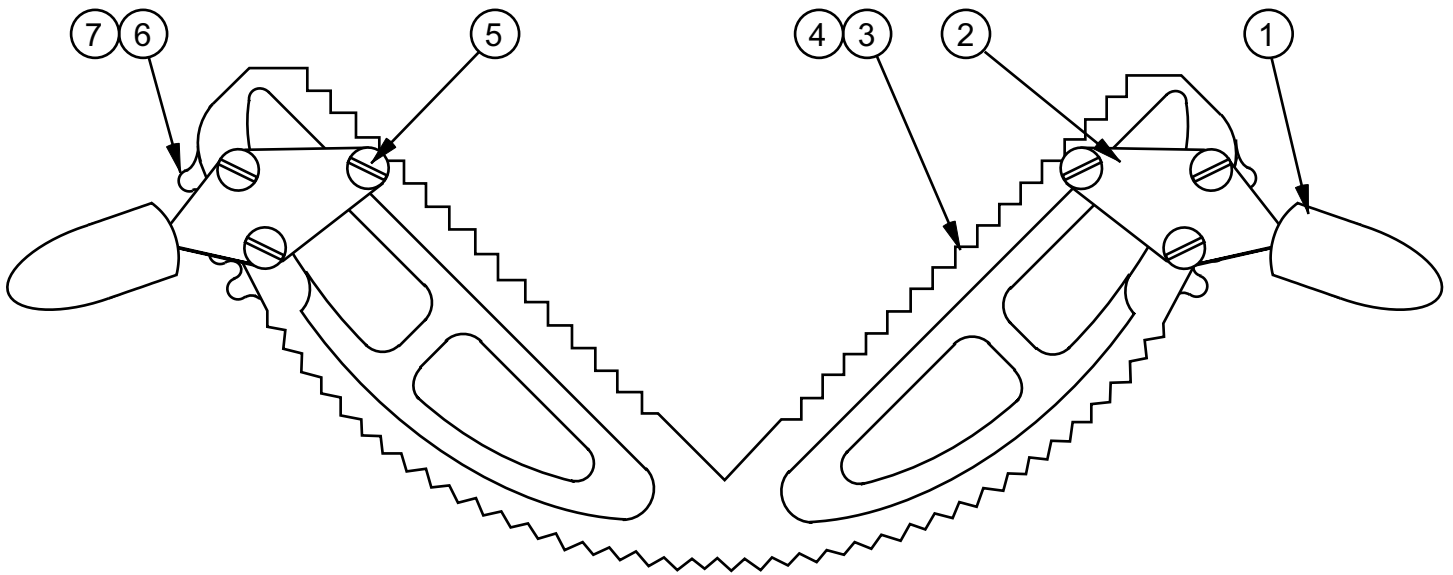

WORK HOLDING JAW ASSEMBLY
5-013007

WORK HOLDING JAW ASSEMBLIES

WORK HOLDING JAW ASSEMBLIES

INDEX NO.	PART NO.	DESCRIPTION	UNITS PER ASS'Y.
Ref.	040262	Work Holder Assembly	
1*	5-013313	. Sprocket	2
2	198698	. Screw, Fill. Hd. Mach. #10-24NC x 1/2	4
3	020386	. Left Arm	1
4	198236	. Screw, Soc. Hd. Cap 1/4-20NC x 1/2	1
5	002162	. Knurled Screw	1
6	198410	. Screw, Soc. Set #10-24NC x 1/4	2
7	020385	. Right Arm	1

*NOTE: Before 2-12-44 On Hydraulic Machines, Use #6-023337 Sprocket With 3/16" Pitch; Specify Pitch of Chain When Ordering.

Ref.	5-013007	Work Holding Jaw Assembly	
1	5-013512	. Jaw Handle	2
2	5-013318	. Bracket	2
3	040678	. Work Holding Jaw Sub-Assembly	1
4	5-013110	. . Work Holding Jaw	1
5	198892	. . Screw, Rd. Hd. Mach. 1/4-20NC x 5/16	6
6	5-013313	. . Sprocket	2
7	199015	. . Screw, Truss Hd. Mach. #10-24NC x 3/8	4

Ref. 34-003107 Work Holding Jaw (Ratchet And Screw Feed Options)

NEW DRG.
S.C.L. 9-18-97
REVISIONS
S.C.L. 2-25-04
S.C.L. 2-12-08

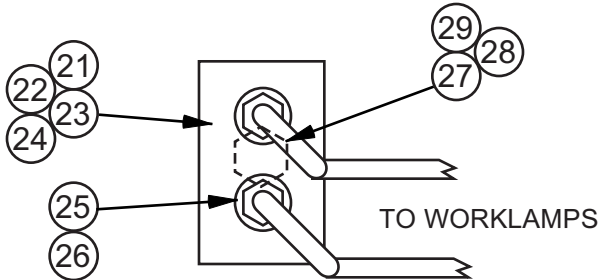
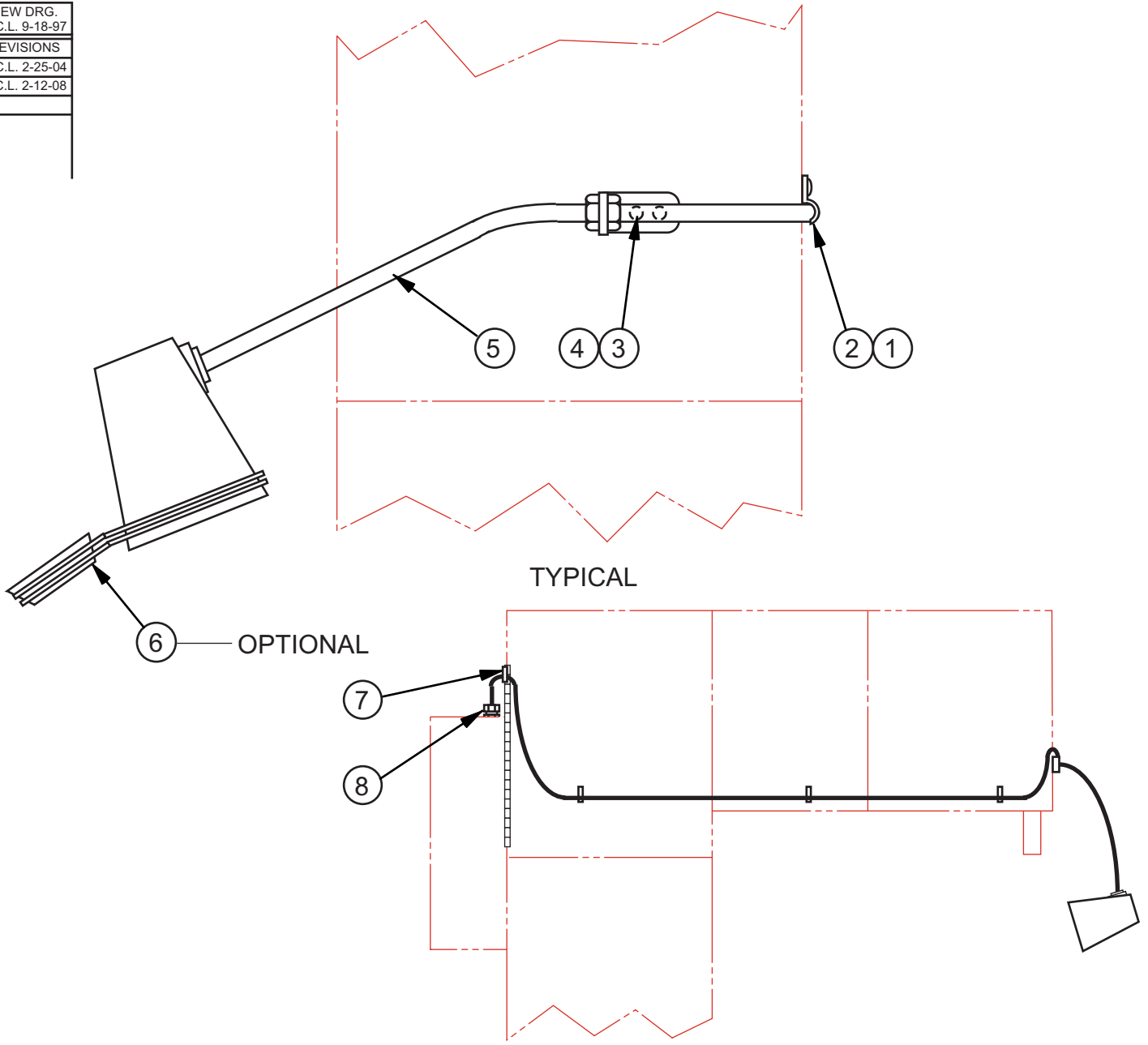

FOR MACHINES WITH 2 WORKLAMPS
(2613-3, 2618-4, 6013-H3)

O.S.H.A. REQUIREMENT:
WIRE DIRECTLY TO CONTROL BOX.
SEE ELECTRICAL SCHEMATIC FOR
CONNECTIONS AND/OR MORE
INFORMATION.

OPTIONAL ON ALL MACHINES.

WORKLAMP ASSEMBLY

WORKLAMP ASSEMBLY

INDEX NO.	PART NO.	DESCRIPTION	UNITS PER ASS'Y.
Ref.	220670	Worklamp Assembly (Standard)	
Ref.	220671	Worklamp Assembly (Extra Work Height)	
1	018172	. Tubing Clamp	A.R.
2	198853	. Screw, Rd. Hd. Mach. #8-32NC x 3/8	A.R.
3	198892	. Screw, Rd. Hd. Mach. 1/4-20NC x 5/16	2
4	199321	. Washer, Lock 1/4 Std.	2
5	221545	. Worklamp (Includes Bracket)	1
	221546	. Worklamp (Includes Bracket) (Extra Work Height)	1
6	138436	. Magnifier (Optional)	1
7	009955	. Nylon Tubing Clamp	1
	198853	. Screw, Rd. Hd. Mach. #8-32NC x 3/8	1
8	201688	. Cord Grip Connector (.200-.394)	1
Ref.	406094	Worklamp Assembly (2 Worklamps) (2613-3, 6013-H3)	
21	100506	. Outlet Box Assembly	1
	002992	. Junction Box (2618-4 Only)	1
22	137173	. Box Cover	1
23	137172	. Gasket	1
24	133826	. Wire Connector	A.R.
25	015139	. Cord Grip Connector	2
26	014411	. Flange Washer	2
27	197156	. Sealtite Conduit 1/2 I.D.	A.R.
28	014545	. Sealtite Connector	2
29	014411	. Flange Washer	2

Use Worklamps Listed Above; Quantity of 2.