

Instruction Manual



SAWING PRODUCTS

3613-V3

Serial No: 568-04101 to

Band Sawing Machine

DAMAGE CLAIM PROCEDURES

VISIBLE DAMAGE AT THE TIME OF DELIVERY:

1. Note damage on carrier's delivery receipt. Accept the shipment. It can be returned later if repairs are not possible in the field.
2. Request a "damage inspection" from the delivery carrier:
 - a. The carrier will send his own people or contract an independent agency to make the inspection.
 - b. The inspector will request a signature on the report and leave a copy.
 - c. The carrier "damage inspection" report is not final. If additional damage is found when repairs are started, contact the carrier for another inspection; or at least give them the details of the damage.
3. Do not move the equipment from the receiving area and keep all shipping materials until carrier "damage inspection" report is complete.
4. If possible, take photographs of the damage and keep them for your files. Photos could possibly prove a claim at a later time.
5. Keep a record of all expenses and be sure they are documented.
6. Repair damage in the field whenever possible. Carriers encourage this to keep expenses down.
7. You have nine (9) months to file a claim.

CONCEALED DAMAGE:

1. You have fourteen (14) days to report damage not noted at time of delivery.
 - a. Report damage as soon as possible. This makes it easier to prove that it did not happen at cosignee's plant.
 - b. Inspect machine(s) carefully before moving from the receiving area. Again, if machine is not moved, it is easier to prove your case.
2. Request a "damage inspection" from the delivery carrier:
 - a. The carrier will send his own people or contract an independent agency to make the inspection.
 - b. The inspector will request a signature on the report and leave a copy.
 - c. The carrier "damage inspection" report is not final. If additional damage is found when repairs are started, contact the carrier for another inspection; or at least give them the details of the damage.
3. Do not move the equipment from the receiving area and keep all shipping materials until carrier "damage inspection" report is complete.
4. If possible, take photographs of the damage and keep them for your files. Photos could possibly prove a claim at a later time.
5. Keep a record of all expenses and be sure they are documented.
6. Repair damage in the field whenever possible. Carriers encourage this to keep expenses down.
7. You have nine (9) months to file a claim.

OPERATOR'S INSTRUCTION MANUAL

METAL CUTTING BAND SAW

MODEL

3613-V3

FIRST SERIAL NO.

568-04101

LAST SERIAL NO.

MACHINE MODEL <input type="text"/>		SERIAL NUMBER <input type="text"/>	
TOTAL MACHINE ELECTRICAL POWER INPUT DATA			
VOLTAGE <input type="text"/>	PHASE <input type="text"/>	HERTZ <input type="text"/>	FULL LOAD AMPS <input type="text"/>
LARGEST CONTROLLED MOTOR <input type="text"/>	OVERCURRENT PROTECTION PROVIDED AT MACHINE SUPPLY TERMINAL		
FIELD ALIGN & ADJUST SUMMARY <input type="text"/>	BAND LENGTH <input type="text"/>		
ELECTRICAL SCHEMATIC NUMBER <input type="text"/>	DATE OF MANUFACTURE <input type="text"/>		
HYDRAULIC SCHEMATIC NUMBER <input type="text"/>	SEE INSTRUCTION MANUAL FOR MACHINE OPERATION AND LUBRICATION DATA		

For your information and future reference, pertinent data concerning your machine should be written in the spaces provided above. This information is printed on a label or stamped on a plate attached to your machine. Be sure to provide machine model and serial numbers with any correspondence or parts orders.

Specifications contained herein were in effect at the time this manual was approved for printing. The DoALL Company, whose policy is one of continuous improvement, reserves the right, however, to change specifications or design at any time without notice and without incurring obligations.

PLEASE READ THIS MANUAL CAREFULLY BEFORE OPERATING THE MACHINE!
For Sales, Parts and Service, call 1-888-362-5572



DoALL SAWING PRODUCTS
2375B TOUHY AVENUE
ELK GROVE, ILLINOIS 60007 U.S.A.

The following registered trademarks of the DoALL Company are used in this manual:
DoALL and Imperial Bi-Metal.

TABLE OF CONTENTS

MACHINE DIMENSIONS

Floor Plan	1
Front View	2

MACHINE FEATURES

Front View	3
Rear View	4

INSTALLATION

Location	5
OSHA Notice!!	5
Unpacking	5
Cleaning	5
Lifting	5
Machine Alignment	5-6
Electrical Installation	6
Preparation for Use	6

OPERATION

Safety Precautions	7
Using the Job Selector	7
Electrical Controls	8
Band Speed Controls	8
Saw Band Preparation	8-10
Post Adjustment	10
Worktable and Tilt Adjustment	11
Wheel Brush and Chip Removal	11
Typical Operation Procedures	11-12

LUBRICATION

Lubrication Chart	14
Lubrication Diagram	15

MAINTENANCE

Replacing Crowned Bandwheel Tires	16
Insert-Type Saw Guides	16
Electric Motors	16
Head Components	16
Wheel Brush	16
Transmission	16
Band Drive Belt	16
Mist Coolant (If Supplied)	16-17
Machine Cleaning	17

TROUBLE SHOOTING	18-19
-------------------------------	-------

ACCESSORIES

Disc Cutter	20
Miter No. 2 Cut-Off (Side Mount)	20
Rip Fence	20
Heavy Work Slides	20-21
Workholding Jaws	21
Air-Operated Power Feed	21
Chip Blower	22
Mist Coolant	22
Band Mist Lubricator	22
Worklight	22
Magnifier	22
Post Elevating Handwheel	22
Worktable Options	22-23
Air-Powered Worktable	23
Universal Calibrated Work Fixture	23-24
Protractor Workstop and Alignment Gage	24
DBW-15 Buttwelder	24
Optional Saw Guide Blocks	25-26
90° Saw Guide Brackets	26
Adjustable Angle Saw Guides	26
Dust Spout	27
Shift Lock	27
Extra Work Height	27
Band Filing	27-28
Band Polishing	28
Laser Line Generator Option	28

How to read your serial number:

Example: 500-001234

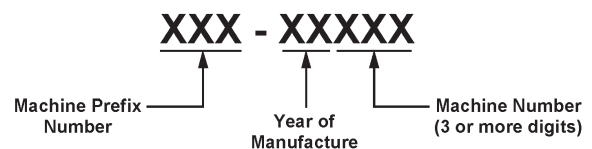

MACHINE DIMENSIONS

INCHES ($\pm .03$)
MILLIMETERS (± 1 mm)

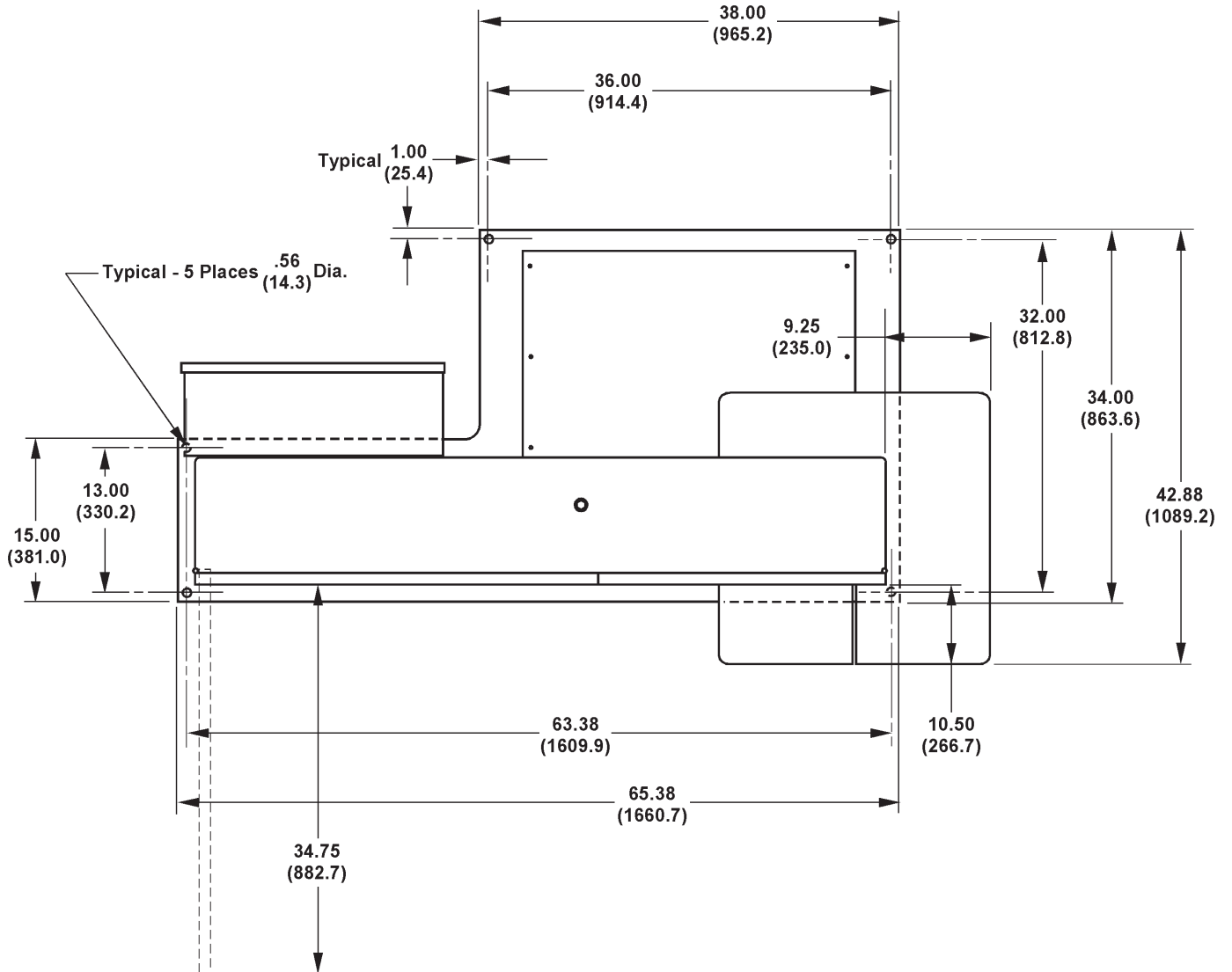

FLOOR PLAN

MACHINE DIMENSIONS (Continued....)

INCHES ($\pm .03$)
MILLIMETERS (± 1 mm)

	Dimensions	
	A	B
Work Height	13" (330.2 mm)	80.17" (2036.3 mm)
	20" (508.0 mm)	88.17" (2239.5 mm)
	24" (609.6 mm)	91.17" (2315.7mm)
	30" (762.0 mm)	97.17" (2467.7 mm)

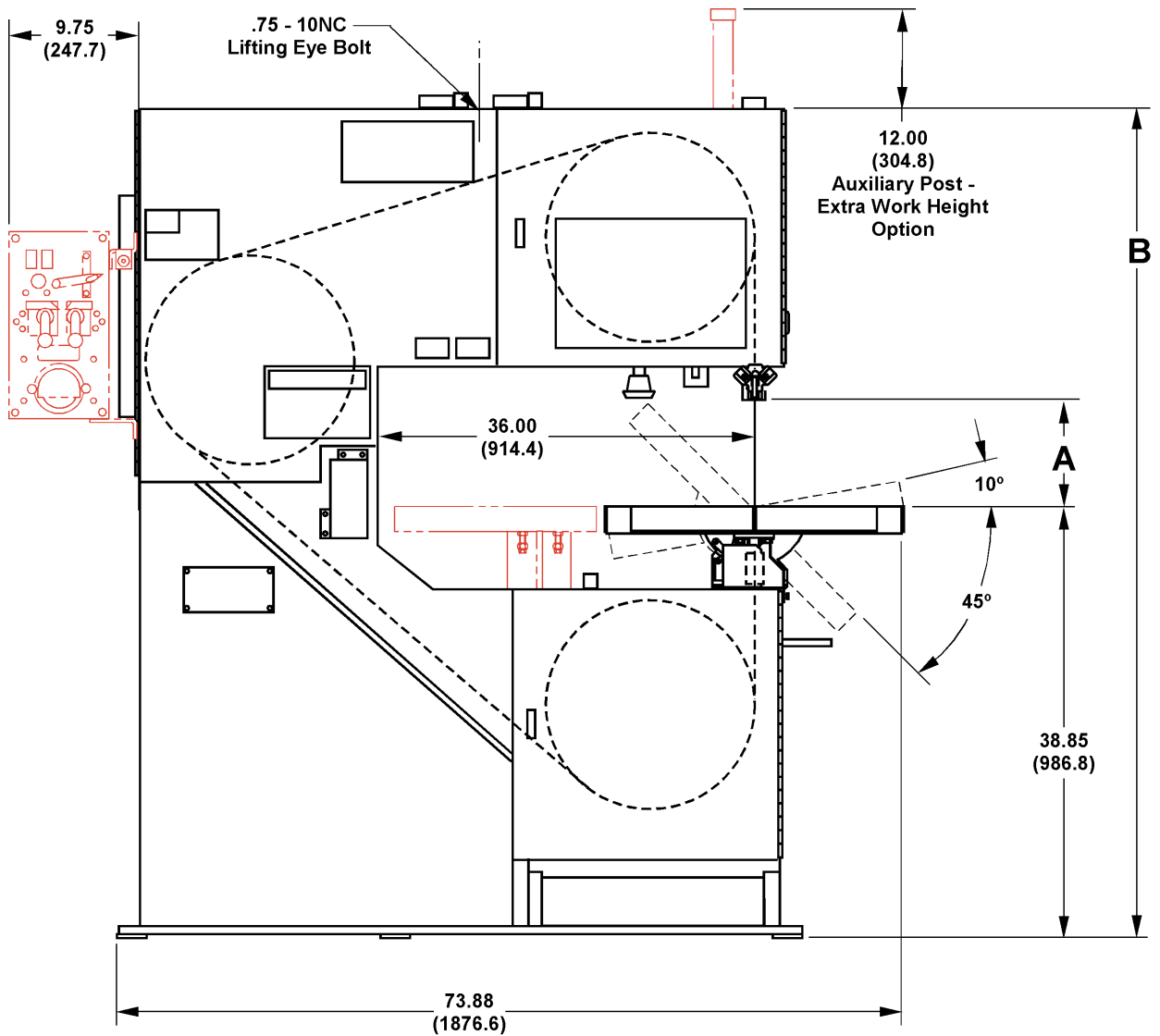

FRONT VIEW

MACHINE FEATURES

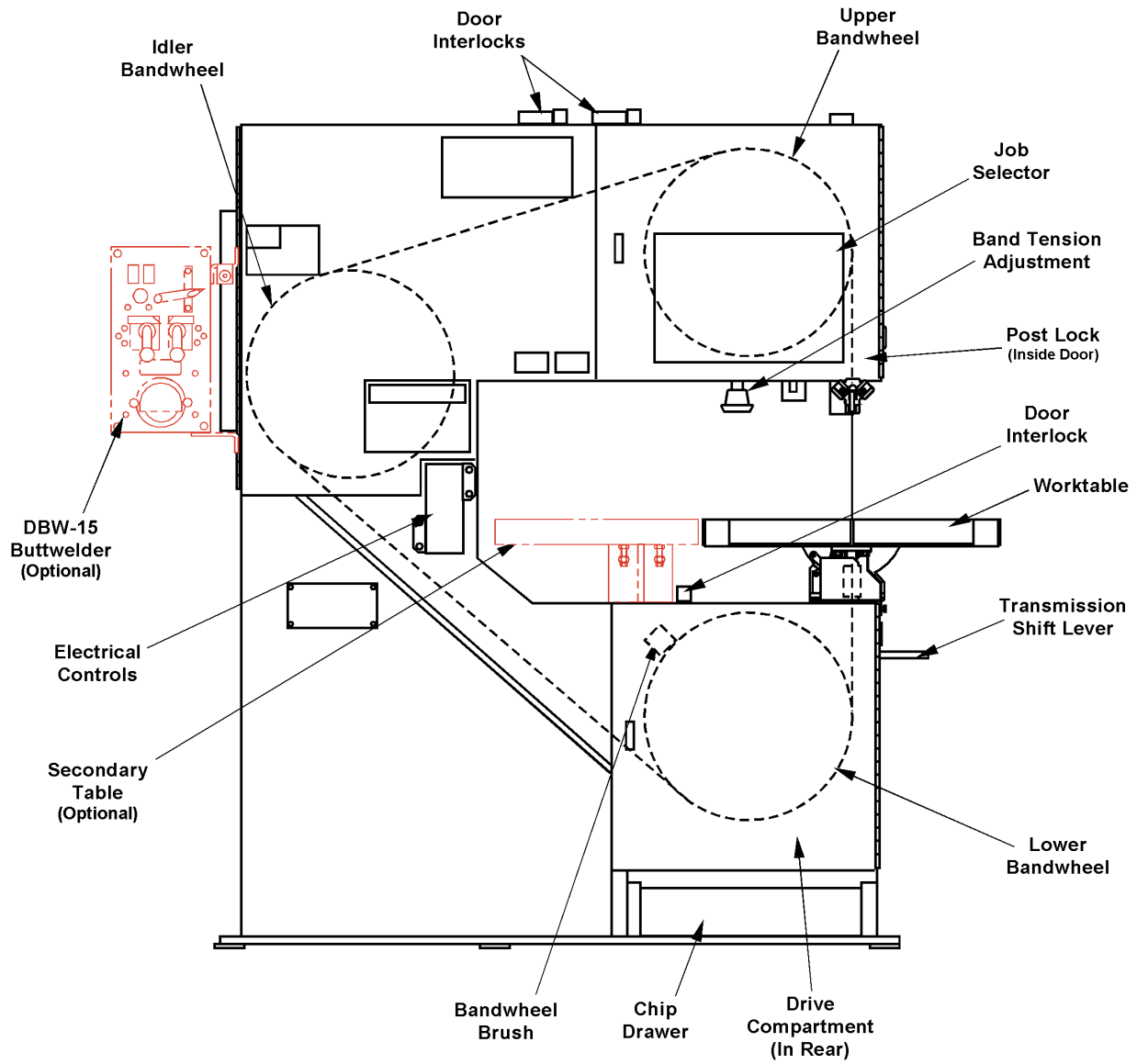

FRONT VIEW

MACHINE FEATURES (Continued....)

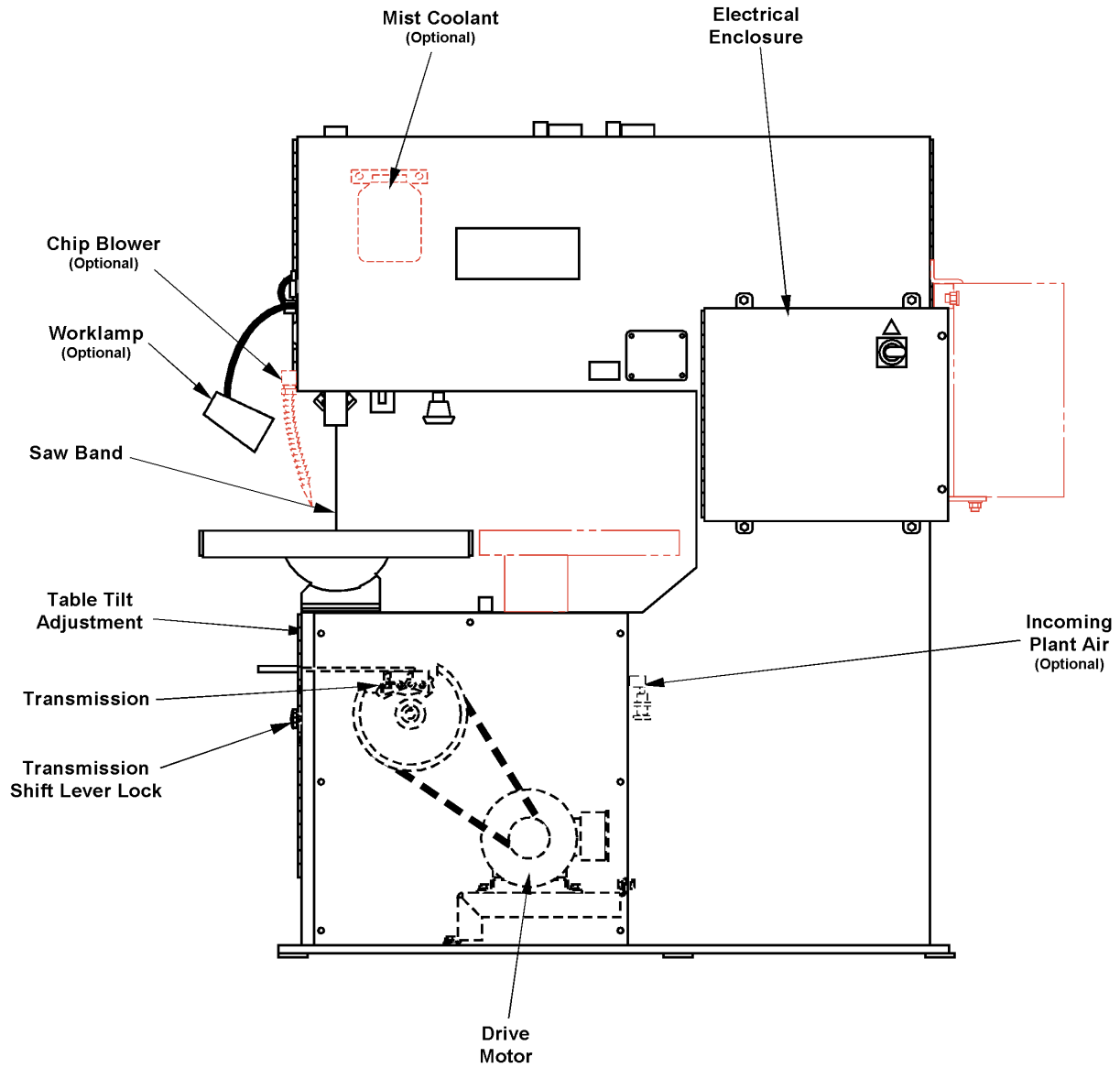

REAR VIEW

INSTALLATION



All the “left”, “right”, “front” and “rear” designations in this manual are as viewed by the operator facing the machine controls on the electrical control box.

LOCATION

1. The floor area required by the standard machine is approximately 55 inches (1399.0 mm) in width by 44.5 inches (1130.3 mm) in length. Machine height for the standard machine is 80.17 inches (2036.3 mm). Refer to pages 1 & 2 for further machine dimensions.
2. Locate the machine to provide adequate space for your sawing needs. Be sure to provide sufficient clearance for: **(a)** Material loading and unloading; **(b)** All door openings; **(c)** Maintenance and lubrication procedures; **(d)** Operation of the any supplied machine accessories.

OSHA NOTICE!!



OSHA Regulation 1910.212 (5B).
Machines designed for a fixed location shall be securely anchored to prevent walking or moving.

UNPACKING

1. The machine is fastened to and shipped on a wooden skid. Overseas shipments are also crated.
2. Carefully remove all protective covers, strapping, hold-down brackets, crating, etc. Then: **(a)** Remove all bolts which fasten the machine to the shipping skid; **(b)** Check inside the rear drive compartment for other removable brackets, extra machine parts or supplies which might have been placed there for shipment. **(c)** Inspect the machine and all parts for shipping damage. Claim procedures are listed on this manual's inside front cover.

CLEANING

1. If necessary, use solvent to remove rust-preventive coating applied to exposed bare metal surfaces before shipment.

LIFTING

1. A tapped hole is located on top of the machine's saw head. Screw a forged 3/4-10NC eye-bolt into this hole for lifting purposes. Net weight of the machine is approximately 1250 pounds (567.0 kg).



DO NOT lift the machine by its sawing head.

MACHINE ALIGNMENT

1. To properly align the machine, place shims between the floor and the base mounting pads until the machine is level with weight resting evenly on all the base pads.

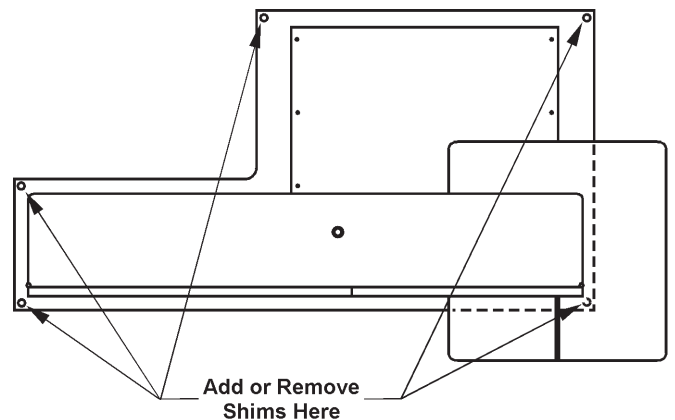

Shim Locations.

2. Square the worktable to the side of the post by loosening the tilt lock bolt located in the machine's frame under the worktable and make the necessary adjustments. If necessary: **(a)** Position the worktable's tilt angle pointer at zero (0) on the tilt scale; **(b)** Tighten the tilt lock bolt.

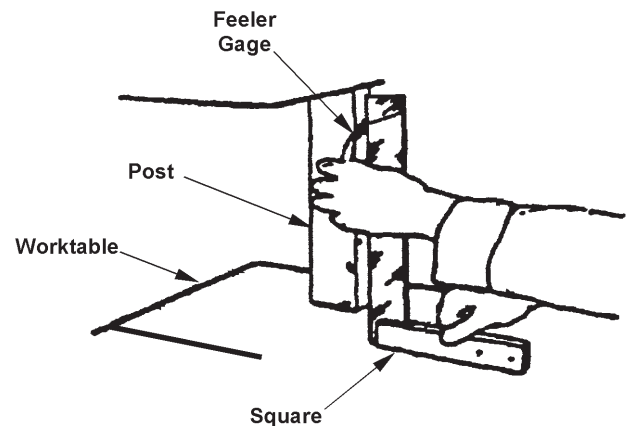

Squaring Worktable to Post.

MACHINE ALIGNMENT (Continued....)

3. Place a good quality, 10 inch (254.0 mm) master square on the worktable against the post's back side. Measure clearance between the post and square near the bottom of the post. Clearance should be within 0.007-inch \pm 0.005-inch (0.18 mm \pm 0.13 mm) at the bottom of the post for standard machines.
4. Add or remove shims under the base pads until the correct post to square clearance is obtained.



The machine must be bolted to the floor for worktable loads over 100 pounds (45.4 kg).

ELECTRICAL INSTALLATION



Electrical installation must be made by authorized electrical maintenance personnel only!

1. Refer to the machine specifications plate on the machine frame to verify that the electrical supply circuit will meet the voltage/phase/frequency/amperage requirements listed. A basic data plate is reproduced on this manual's introductory page.
2. Bring the incoming power leads into the machine's electrical box. Refer to the electrical schematic, if necessary, when making the connections.
3. Turn the disconnect switch on the electrical box to ON. Then: **(a)** Alternately jog the **Band Start** and **Stop** pushbuttons; **(b)** Check to make sure the saw band is running in a **clockwise** motion; **(c)** Reverse the leads if saw band movement is incorrect.

PREPARATION FOR USE

1. Check the transmission oil level. Capacity is 1 quart (0.95 liters). If the reservoir level is low (or empty): **(a)** Check to see that the transmission plug is installed tightly; **(b)** See the "*Maintenance*" section for proper procedure of checking and/or filling the transmission. **(c)** Refer to the Lubrication Chart later in this manual for recommended lubricants.
2. Shop air is required to operate the optional chip blower, mist coolant, sliding air table and/or band lubricator. Incoming air supply should be between 80 and 90 psi (5.5 and 6.2 bar or 5.6 and 6.3 kg/cm²).



DO NOT exceed 90 psi (6.2 bar or 6.3 kg/cm²).

3. Check the band mist lubricator unit (if supplied) for the proper reservoir level. Refer to the manufacturer supplied literature for reservoir capacity and recommended procedures.
4. Make sure all other points listed by the Lubrication Chart have been properly checked and/or serviced.

OPERATION

SAFETY PRECAUTIONS

SUPERVISOR, MAKE SURE THAT THE OPERATOR UNDERSTANDS THE FOLLOWING:

WARNING

THESE PRECAUTIONS MUST BE FOLLOWED WHEN OPERATING OR SERVICING THIS MACHINE:

- NEVER WEAR GLOVES WHILE OPERATING THIS MACHINE.
- NEVER OPERATE MACHINE WITHOUT SAFETY GLASSES.
- NEVER OPERATE MACHINE WITHOUT SAW BLADE GUARDS IN PLACE.
- NEVER OPERATE MACHINE BEFORE CLOSING BAND WHEEL DOOR COVERS.
- NEVER OPERATE MACHINE FROM REAR.
- NEVER REMOVE CUT-OFF PIECES WHILE MACHINE IS RUNNING.
- READ INSTRUCTION MANUALS BEFORE OPERATING THIS MACHINE.
- AVOID CONTACT WITH COOLANT, ESPECIALLY GUARD YOUR EYES.
- BRING ADJUSTABLE SAW GUIDE AND GUARD AS CLOSE TO WORK AS POSSIBLE.
- DISCONNECT ALL ELECTRICAL POWER BEFORE SERVICING.
- DO NOT SERVICE, REPAIR OR ADJUST MACHINE WITHOUT PROPER INSTRUCTION FROM YOUR SUPERVISOR AND WITHOUT READING AND FULLY UNDERSTANDING THE INSTRUCTION MANUAL.
- USE A FIXTURE TO FEED MATERIAL.
- CLOSE AND SECURE BAND WHEEL COVERS BEFORE TENSIONING BAND OR STARTING MACHINE.
- STEP TO ONE SIDE AND AWAY FROM WELDING UNIT BEFORE WELDING A SAW BAND.
- KEEP HANDS AWAY FROM MOVING SAW BLADES AND VISE AREA.
- INSTALL FRICTION BAND AND SPARK SHIELD BEFORE FRICTION SAWING.
- USE EXTREME CARE IN HANDLING BLADES.
- USE A DUST COLLECTOR WHEN SAWING GENERATES DUST.

**MAKE SAFETY THE RULE AND FOLLOW SAFE SHOP PRACTICES.
DO NOT REMOVE OR DEFACE THIS SIGN**

404476

Warning Label - READ and UNDERSTAND.

USING THE JOB SELECTOR

- Refer to the Job Selector chart located on the upper bandwheel door. It has information about the recommended band type and pitch, band speeds and cutting rates according to the type of material to be cut and its thickness. It also has a radius guide that shows the minimum radii cuts possible with various saw band widths.
- To use, find the material to be cut in the first column. Then move to the right to find information on coolant application if any, band speed recommendations, feed rates and band type and pitch.



The Job Selector is a guide only and the recommendations shown can be adjusted to meet special material requirements.

RADIUS GUIDE INCHES 1.0 1.5 2.0 2.5 3.0 3.5 4.0 4.5 5.0 5.5 6.0 6.5 7.0 7.5 8.0 8.5 9.0 9.5 10.0	MATERIAL A.I.S.I.	COOLANT F = FLOOD M = MIST N = NONE	WORK HEIGHT FEET	BAND SPEED FEET MIN	FEED MM INCH	BAND-TEETH/INCH L = LIGHT M = MEDIUM H = HEAVY	TOOTH PITCH	
							TOOTH PITCH MM INCH	TOOTH PITCH MM INCH
1.0 (25.4)	1018-1045	F	11"-11"	13-25	100-150	L	1/8"	1/8"
1.5 (38.1)	1018-1045	F	11"-11"	13-25	100-150	L	1/8"	1/8"
2.0 (50.8)	1018-1045	F	11"-11"	13-25	100-150	L	1/8"	1/8"
2.5 (63.5)	1018-1045	F	11"-11"	13-25	100-150	L	1/8"	1/8"
3.0 (76.2)	1018-1045	F	11"-11"	13-25	100-150	L	1/8"	1/8"
3.5 (88.9)	1018-1045	F	11"-11"	13-25	100-150	L	1/8"	1/8"
4.0 (101.6)	1018-1045	F	11"-11"	13-25	100-150	L	1/8"	1/8"
4.5 (114.3)	1018-1045	F	11"-11"	13-25	100-150	L	1/8"	1/8"
5.0 (127.0)	1018-1045	F	11"-11"	13-25	100-150	L	1/8"	1/8"
5.5 (139.7)	1018-1045	F	11"-11"	13-25	100-150	L	1/8"	1/8"
6.0 (152.4)	1018-1045	F	11"-11"	13-25	100-150	L	1/8"	1/8"
6.5 (165.1)	1018-1045	F	11"-11"	13-25	100-150	L	1/8"	1/8"
7.0 (177.8)	1018-1045	F	11"-11"	13-25	100-150	L	1/8"	1/8"
7.5 (190.5)	1018-1045	F	11"-11"	13-25	100-150	L	1/8"	1/8"
8.0 (203.2)	1018-1045	F	11"-11"	13-25	100-150	L	1/8"	1/8"
8.5 (215.9)	1018-1045	F	11"-11"	13-25	100-150	L	1/8"	1/8"
9.0 (228.6)	1018-1045	F	11"-11"	13-25	100-150	L	1/8"	1/8"
9.5 (241.3)	1018-1045	F	11"-11"	13-25	100-150	L	1/8"	1/8"
10.0 (254.0)	1018-1045	F	11"-11"	13-25	100-150	L	1/8"	1/8"

Job Selector.

ELECTRICAL CONTROLS

1. **Foot Switch.** Does not apply to this machine.
- **Laser (Optional).** This control turns the optional laser line generator "OFF" and "ON".
2. **Hydraulic.** Not applicable when plugged.
3. **Mist Lube (Optional).** This switch turns the optional band mist lubricator "OFF" and "ON".
4. **Band Start/Stop.** Push this upper green portion of the button to start the band drive motor. Push the lower red portion of the button to stop the band drive motor.

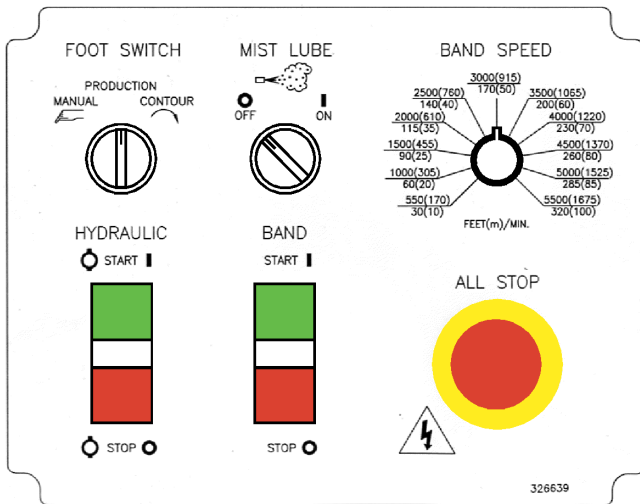

Typical Electrical Control Box.

5. **All Stop (Emergency Stop).** Push this red mushroom head button to stop all functions of the machine. To resume operation, the button must be reset by rotating the button head **clockwise** until the head pops up.

Other Controls

1. **Disconnect Switch.** This switch, located on the electrical control box enclosure, supplies incoming power to the machine.
2. **Worklight (Optional).** A switch on the worklight turns the light "OFF" and "ON".
3. Controls for the optional DBW-15 Buttwelder are described in a separate instruction manual.

BAND SPEED CONTROLS

1. The transmission gear shift lever is located on the machine's right side below the worktable. The band speed control is located on the electrical control box.

2. The operator can select between "high" and "low" band speed ranges by hold down the shift lever lock and move the transmission gear shift lever: **(a)** To the left to obtain "high" range speeds -- 550 to 5500 fpm (170 to 1675 m/min); **(b)** To the right to obtain "low" range speeds -- 30 to 320 fpm (10 to 100 m/min).
- The "neutral" position is in the middle of the slot. The band speed **MUST** be at its lowest speed before the shift lever can be moved to "neutral".
3. Variable speed within both ranges is changed by turning the **Band Speed** knob. Turn the control **clockwise** to "increase" the band speed, **counterclockwise** to "decrease" it.
4. During machine operation, keep the following band speed and gear shifting precautions in mind:



Adjust the band speed only while the machine is running.



Always turn the band speed knob to its lowest speed before stopping the machine or shifting into "neutral".



Always allow the saw band to stop completely before opening any bandwheel door.



Stop the machine to shift gears. Then turn the drive bandwheel by hand to engage the clutch while shifting.



DO NOT attempt to force the gear shift lever into place.

5. If the transmission gears are not in position to mesh: **(a)** Turn the machine off; **(b)** Open the lower bandwheel door, and; **(c)** Manually turn the lower bandwheel until meshing occurs. **DO NOT attempt to force the gear shift lever into place.**

SAW BAND PREPARATION

Saw Band Selection

1. The machine is equipped with an Imperial Bi-Metal Super Silencer saw band that is 154 inches (3911.6 mm) long. It will accept saw band widths from 1/16 to one (1) inch (1.6 to 25.4 mm).
2. Standard equipment includes:
 - One (1) set of high-speed, insert-type saw guide blocks for saw bands from 1/16 to 1/2 inch (1.6 to 12.7 mm) wide.

SAW BAND PREPARATION (Continued...)

- One (1) set of steel saw guide inserts for saw bands 1/4 to 1/2 inch (6.3 to 12.7 mm) wide.



Information about all DoALL saw bands can be obtained from a DoALL sales representative.

Insert-Type Saw Guide Adjustment



These instructions apply to both the upper and lower insert-type saw guide blocks.

1. Select the saw guide blocks and inserts marked for the width of the saw band to be used. Then: **(a)** Place the left insert in the left milled slot; **(b)** Tighten the insert screw slightly so that the insert will slide in the slot, yet still hold its correct position when released.

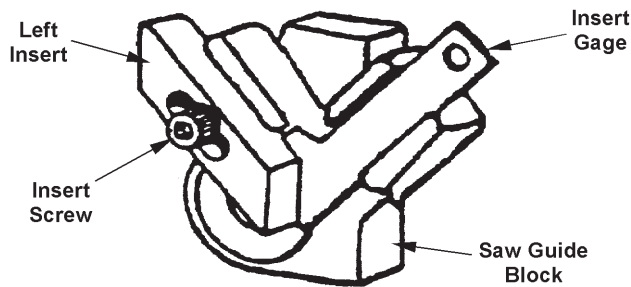

Upper Saw Guide Block Shown

Positioning the Left Insert.

2. Select the insert gage which matches the size of the saw band being used. Then: **(a)** Place the insert gage in the right slot; **(b)** Adjust the left insert to fit exactly into the notched end of the gage; **(c)** Tighten the left insert screw.
3. Place the right insert in its slot and tighten the insert lightly. Then: **(a)** Place the gage edgewise between both inserts; **(b)** Lower the right insert until it rests against the gage; **(c)** Tighten the right insert screw.

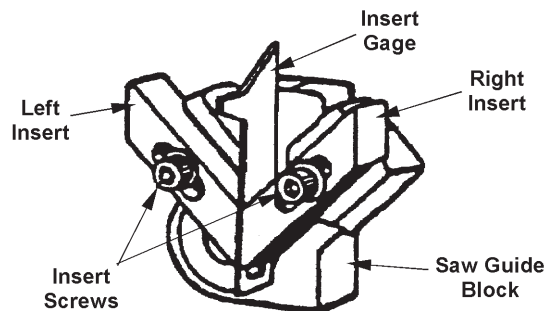

Upper Saw Guide Block Shown

Positioning the Right Insert.



Insert-type saw guides are recommended for maximum band speeds of 1300 fpm (390 m/min) for production sawing, or up to 5000 fpm (1500 m/min) for occasional sawing. Use optional roller saw guides for continuous sawing over 1300 fpm (390 m/min).

Saw Band Removal



Always use extreme care when handling saw bands. Wear gloves.

1. Release saw band tension. Then: **(a)** Open all bandwheel doors; **(b)** Remove the post saw band guard; **(c)** Loosen the screw holding the worktable's sawing slot clamp bar and move it aside; **(d)** Loosen the saw guide inserts.
2. Carefully slip the worn or broken saw band from between the saw guide inserts and remove it from around the bandwheels. Then work the saw band out through the slot in the machine frame.

Saw Band Installation



Always use extreme care when handling saw bands. Wear gloves.

1. Remove the old saw band according to the directions above. Then: **(a)** Place the new saw band carefully through the slot in the machine frame; **(b)** Place the new saw band carefully around the bandwheels and between the upper and lower saw guide inserts; **(c)** The saw band should track along the center of the bandwheel tires.
2. Remove the new saw band's protective Saw Cap. Then: **(a)** Apply the band tension recommended by the scale adjacent to the tension adjustment knob; **(b)** Reinstall the post saw band guard; **(c)** Reposition and secure the worktable sawing slot clamp bar; **(d)** Close all bandwheel doors.

Saw Band Tension Adjustment

1. Saw band tension is adjusted by turning the knob located below the machine's sawing head (this knob also is used to lock the post in place).
2. A scale showing the recommended tension for various saw band widths is located to the right of the tension adjustment knob. Scale numbers represent the recommended tensions for common saw band gages and pitches.

SAW BAND PREPARATION (Continued...)

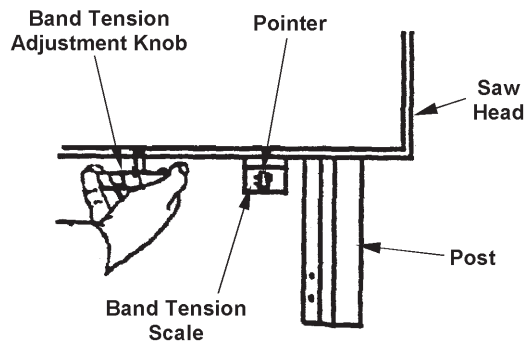

Adjusting Saw Band Tension.

3. The following are operator tensioning recommendations:

- **Reduce** the recommended band tension when using saw bands with a coarser pitch or lighter gage.
- **Increase** the recommended band tension when using heavier gage saw bands.

Saw Band Tracking

1. The upper bandwheel can be tilted a maximum of three (3) inches (76.2 mm) forward and backward to help obtain correct saw band tracking. A saw band is tracking properly when the saw band center follows the center of both crowned rubber bandwheel tires.
2. The following tracking procedures are to be performed with the band drive motor off and the transmission in "neutral": **(a)** Open both bandwheel doors; **(b)** Manually turn the bandwheels to observe how the saw band is tracking.

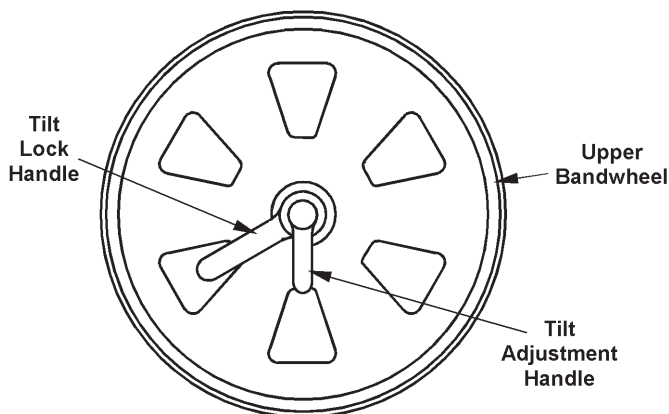

Tilt Adjustment Handles.

3. To adjust bandwheel tilt if tracking is not correct: **(a)** Loosen the tilt lock handle; **(b)** Turn the tilt adjustment handle until the saw band tracks correctly on the bandwheel tires; **(c)** Retighten the tilt lock handle.
- The idler bandwheel has tilt knobs instead of handles but the procedure is still the same.
4. Close all bandwheel doors.

POST ADJUSTMENT

1. Post and upper saw guide elevation can be adjusted to accept workpieces with heights varying up to 13 inches (330.2 mm).

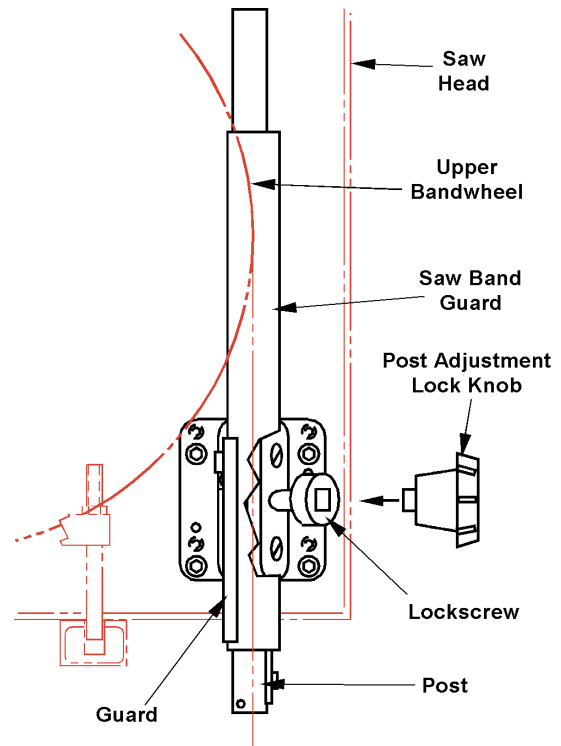

Post Adjustment.

2. To adjust: **(a)** Loosen the lockscrew located inside the upper bandwheel door by using the adjustment knob and turn **counterclockwise** (this knob also used for band tension adjustment); **(b)** Raise or lower the post manually to the desired position; **(c)** Turn the adjustment knob **clockwise** to lock the post in position.
3. Always keep the post and upper saw guide as close as possible to the workpiece and the band guard in place at all times while sawing.
4. Some machines have a optional post elevating handwheel which uses a set of gears to raise and lower the post. Refer to the "Accessories" section for use of this option.

WORKTABLE AND TILT ADJUSTMENT

1. The standard worktable measures 26 by 26 inches (660.4 by 660.4 mm). Its load capacity is 500 pounds (226.8 kg) evenly distributed with NO impact.



The machine must be bolted to the floor for table loads over 100 pounds (45.4 kg).

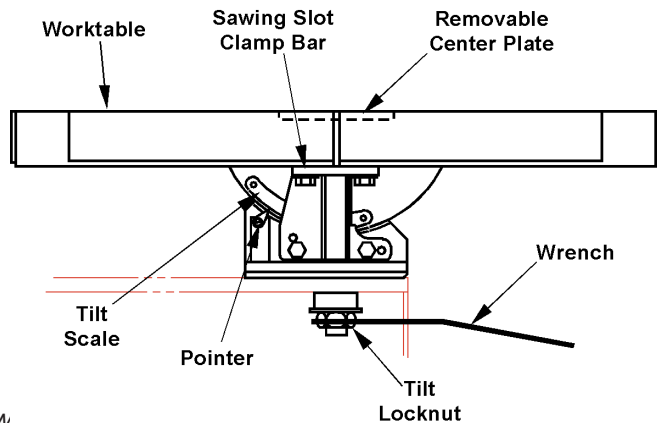

Worktable.

2. The worktable can be tilted manually up to 10° left and 45° right -- primarily for sawing compound angles. The amount of worktable tilt is indicated by a pointer and a trunnion-mounted calibrated scale.
3. To tilt the worktable: **(a)** Use the wrench provided to reach through the machine frame and under the worktable to loosen the tilt locknut; **(b)** Tilt the worktable manually until the pointer reaches desired angle shown on the scale; **(c)** Tighten the tilt locknut.
4. The worktable is drilled and tapped on three (3) sides to attach accessory equipment. Its removable center plate can be replaced with optional plates for band filing and band polishing and other various options.

WHEEL BRUSH AND CHIP REMOVAL

1. A brush, located on the lower bandwheel approximately in the ten (10) o'clock position, cleans metal chips from the bandwheel during machine operation. Removed chips drop into a removable pan in the machine base. This pan should be emptied periodically.



DO NOT open the bandwheel doors until saw band has completely stopped.

2. During operation, chips and other debris may accumulate around such machine areas as saw guides, worktable surfaces, bandwheels, slides, etc. Remove this debris as soon as possible. **The DoALL Company recommends removing chip collections at least twice per each eight (8) hour shift, and more often with heavier use.**

TYPICAL SAWING PROCEDURES

Set-Up

1. These procedures assume that the following machine conditions exist: **(a)** The machine has been properly installed and aligned; **(b)** The band drive motor is off; **(c)** The proper saw band has been installed, is correctly tracked and tensioned; **(d)** All lubrication procedures have been carried out.

Procedure

1. Raise the post high enough so that the upper saw guide can not be damaged while stock is being loaded onto the worktable.
2. Tilt the worktable to the desired angle and lock it in place.
3. Load stock to be cut onto the worktable. Clamp the stock if required.
4. Lower the post until the upper saw guide is just above the stock, but **NOT** touching.
5. Determine the band speed range and desired band speed for the procedure to be undertaken. Then: **(a)** Use the transmission gear shift lever to choose between "high" and "low" band speed ranges; **(b)** Push the **Band Start** button; **(c)** Turn the **Band Speed** knob to the band speed desired.
6. Before starting the cut, make sure to adjust the mist coolant spray (if supplied) onto the saw band and cutting area.
7. Carefully move the stock toward the saw band and begin the cut. Adjust the band speed as necessary during the cutting procedure.
8. After the cut has been finished: **(a)** Turn the **Band Speed** knob to its lowest speed; **(b)** Push the **Band Stop** button; **(c)** Remove the piece just cut from the worktable; **(d)** Reposition the stock to begin another cut; **(e)** Push the **Band Start** button and then set the band speed.

TYPICAL SAWING PROCEDURES

Continued....)

9. The following are important sawing precautions which should be observed:



DO NOT feed work so rapidly that saw band twisting or bowing occurs.



Reduce the feed force when cutting into an opening to prevent saw band damage.



For future reference, keep a record of band speeds, coolant application, etc. and other settings for successful jobs.

Contour Sawing

1. Procedures for stock set-up and band speed adjustment are the same as noted for production sawing except that contour sawing of large, heavy stock will require the use of optional air-operated power feed or air-powered worktable and a heavy gage saw band.

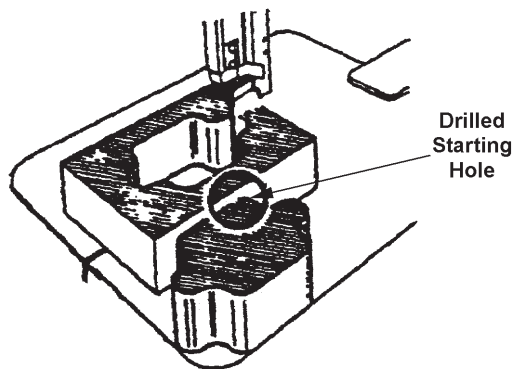

Starting Hole for Sharp Contour Cutting.

2. A hole is usually drilled in the stockpiece when a sharp corner is to be cut, as shown in the illustration. However, a corner may also be by-passed by cutting a curve, and leaving the remainder to be notched out later.

Internal Contours

1. To prepare for internal contour sawing: **(a)** Drill a starting hole in the stock; **(b)** Run the saw band through the hole; **(c)** Weld the saw band. **Insulate the saw band from contact with the stock or the worktable will insure a better weld.**

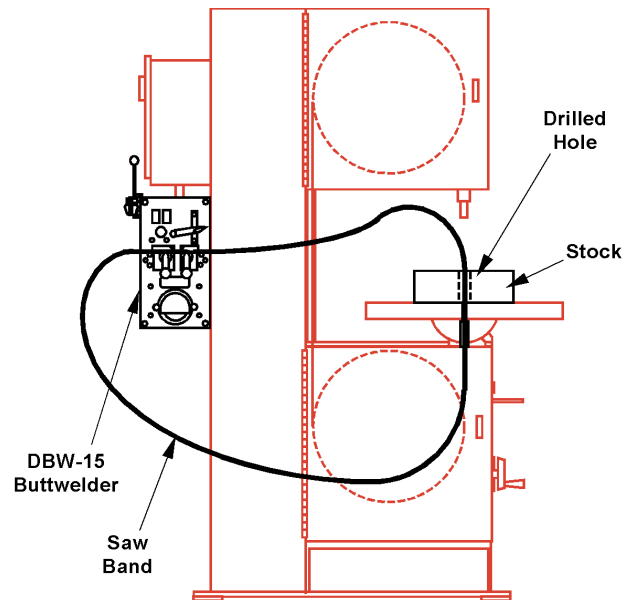

Internal Contour Sawing.

2. The diameter of the drilled starting hole is determined by the size of the saw band being used. Use the widest possible saw band for cutting the curve.
3. Attempting to cut too small a radius with too wide a saw band will cause binding, and the lower bandwheel may become grooved. The chart on the Job Selector shows minimum radii cuts possible with various saw band widths.
4. Radii chart recommendations are based on sawing relatively thin stock. Consider these variations: **(a)** Use a heavy gage saw band for heavy stock sawing; **(b)** Use a narrower than recommended saw band when sawing stock more than one (1) inch (25.4 mm) thick.

LUBRICATION
NEXT 2 PAGES

LUBRICATION

LUBRICATION CHART

LUBRICATION POINT NO.	LOCATION DESCRIPTION AND SERVICE RECOMMENDATIONS	LUBRICATION INTERVAL*	RECOMMENDED LUBRICANT
1	Band Tension Screw and Bearing. Clean and apply oil.	MONTHLY	High quality, rust and oxidation-inhibited, medium hydraulic and general purpose industrial oil. ISO-VG Grade 68 (Formerly ASTM Grade No. 315). Union 76, UNAX RX 68, or equivalent.
2	Post, Optional Post Elevating and Gears. Clean and apply oil.	MONTHLY	
3	Upper Bandwheel Slide, Hinge and Tilt Screws. Clean and apply oil.	MONTHLY	
4	Table Trunnion. Oil tilt surfaces.	MONTHLY	
5	Transmission Shift Linkage and Interlock. Clean and apply oil as required.	MONTHLY	
6	Micellaneous: Slides, Hinges, Pivot Points, Component Parts, unpainted Surfaces, etc. Clean and apply oil as required.	CHECK MONTHLY	
7	Accessory Equipment When Supplied. Keep clean and apply oil as required to maintain proper function, reduce wear and corrosion, etc.	CHECK MONTHLY	
8	Transmission. One (1) quart (0.95 liter) capacity. Proper oil level must be maintained. Drain and refill yearly or when required.	CHECK MONTHLY	High quality, EP (extreme pressure), multi-purpose gear oil. S.A.E. Grade No. 90 Union 76, MP Gear Lube 90, or equivalent.
9	Electric Motor. Band Drive.	Lubricate (if any) per manufacturer's recommendations.	
10	Mist Coolant Reservoir (Optional). Keep filled and hoses clear.	CHECK DAILY/ AS REQUIRED	Premium quality, saw band coolant and lubricant. DoALL cutting fluids and/or oils (AL-2000).
11	Band Mist Lubricator (Optional). Keep filled and hoses clear.	CHECK DAILY/ AS REQUIRED	Contact your DoALL sales representative for the best oils and/or fluids for your application. DoALL cutting fluids and/or oils.
12	DBW-15 Butt welder (Optional).	Lubricate as required per DBW-15 Instruction Manual.	

* Lubrication intervals are based on a 8-hour day, 40-hour week.
Lubricate more often with heavier use.

LUBRICATION DIAGRAM

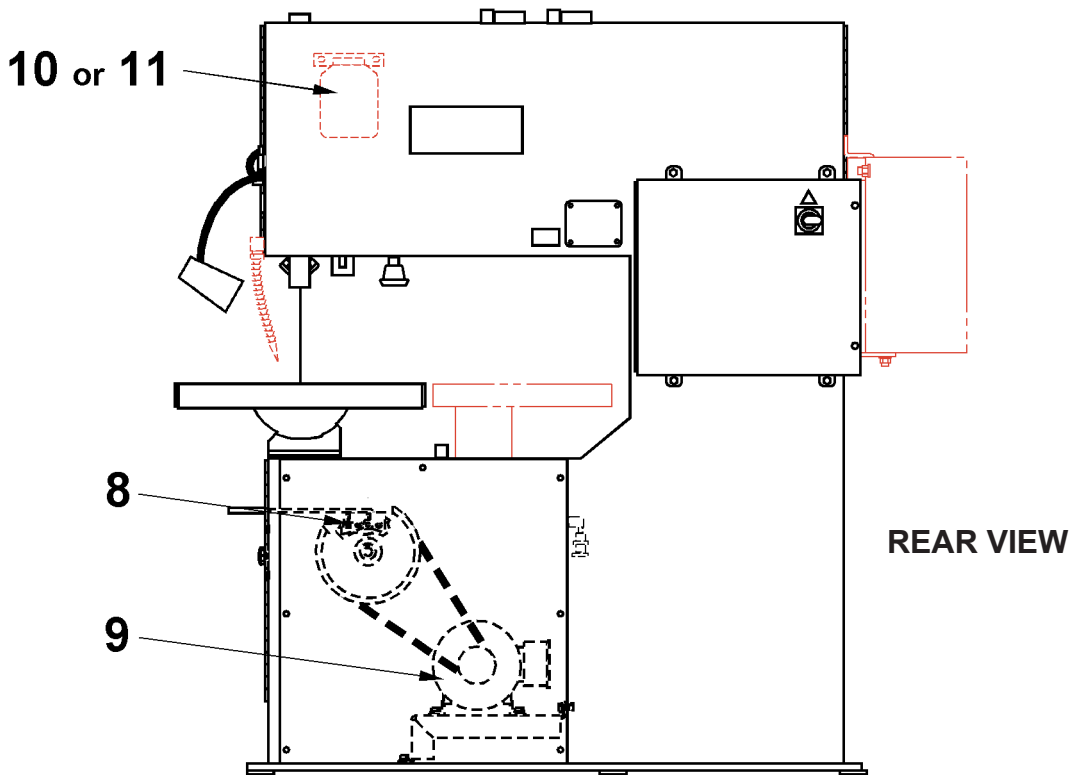
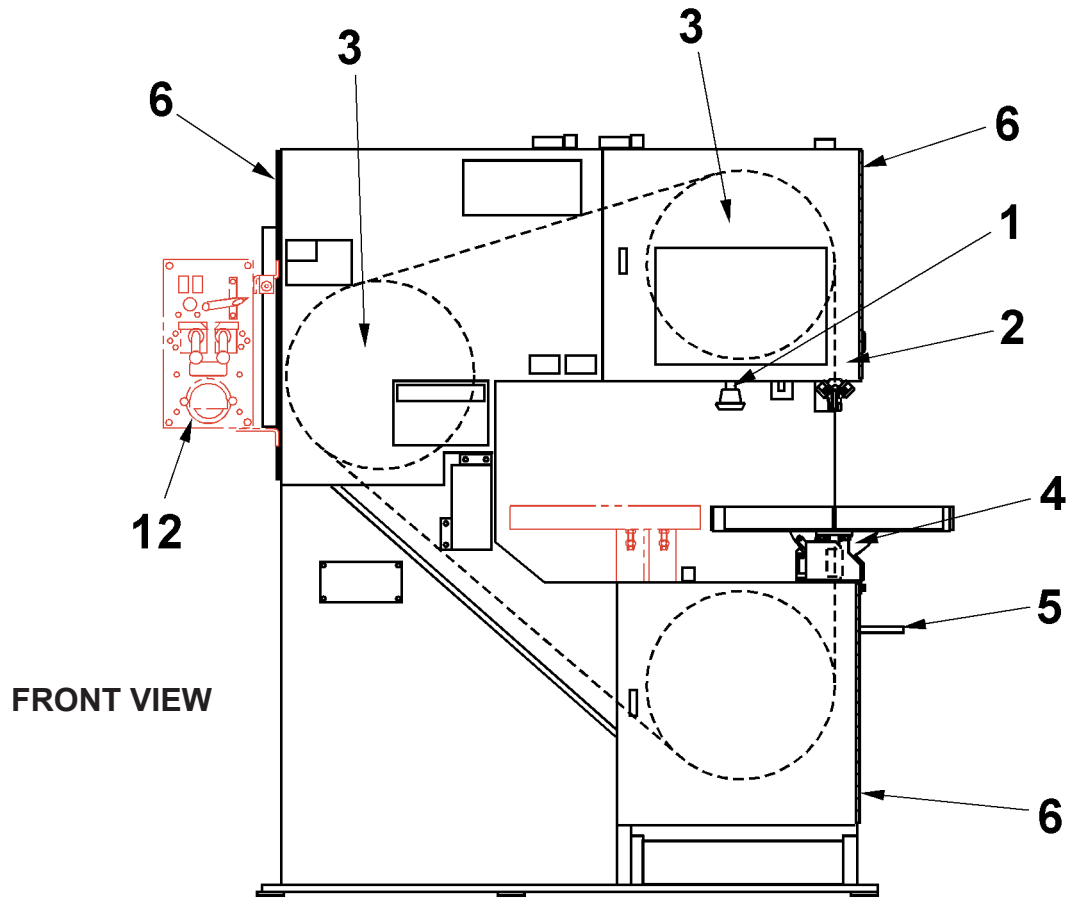

MAINTENANCE

REPLACING CROWNED BANDWHEEL TIRES

1. Loosen the worn tire with a screwdriver or other flat tool.
2. Stretch the tire if necessary to remove it.
3. Clean the bandwheel and install a new tire by stretching it over the bandwheel.

INSERT-TYPE SAW GUIDES

Back-Up Inserts

1. Reverse back-up inserts for additional wear life, then replace when all surfaces are worn.

Roller Back-Up Bearing

1. These bearings are sealed and packed for life with a special lubricant. They can be replaced by: **(a)** Removing the snap ring; **(b)** Pulling out the bearing and shaft; **(c)** New bearings are easily installed with a light press fit.

ELECTRIC MOTORS

1. Follow the manufacturer's maintenance instructions for each electric motor.

HEAD COMPONENTS

1. Wipe oil onto the post occasionally. Then move the post up and down through the slide block several times.
2. Oil the upper bandwheel slide and band tension screw each month.
3. Wheel bearings are sealed and lubricated for life.

WHEEL BRUSH

1. Check the lower bandwheel brush occasionally for correct position. Adjust the brush so it just touches the bandwheel tire.



Too much pressure of the brush will score the bandwheel tire.

2. Replace the brush when necessary.

TRANSMISSION

1. Drain, flush, and refill the transmission yearly. Fill to the bottom of the check plug opening with oil recommended by the Lubrication Chart.

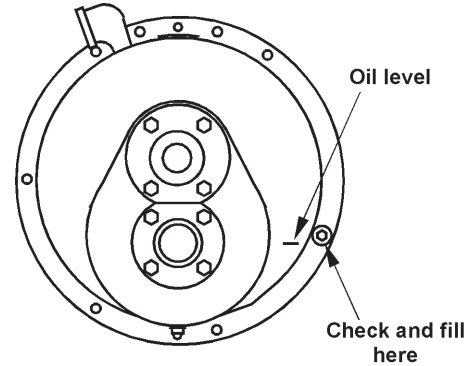

Checking Oil Level.

2. Check often for seal leaks around the shaft.
3. Immediately investigate any loud or unusual noises, or rough operating vibration.
4. Return a faulty transmission to the factory for repair.



Correct new transmission installation is extremely important because careful alignment is necessary. Installation by a DoALL service representative is highly recommended.

BAND DRIVE BELT

1. The belt driving the input sheave will stretch during use. This stretch should be taken up by moving the drive motor on its mounting plate.
2. To replace the belt: **(a)** Loosen the screws that mount the drive motor and slide the motor to the left; **(b)** Slip the old belt from the pulleys and install the new one; **(c)** Slide the drive motor to the right to tighten the belt so there is very little deflection of the belt; **(d)** When correct belt tension is achieved, tighten the screws.

MIST COOLANT (If Supplied)

1. Intermittent coolant stream indicates an air leak. Check all joints.
2. Clogging may occur if waxed-based or other coolants are used. Your DoALL sales representative can provide complete information about various coolants.

MIST COOLANT (Continued....)

3. Keep the mist applicator nozzle and filter clean. If the center nylon coolant tube needs replacing, remove the entire applicator tube. Insert new nylon tube and trim off excess flush with nozzle. Make sure all joints are sealed and tight after applicator tube is reinstalled.

MACHINE CLEANING



Stop the machine when cleaning the machine or opening bandwheel doors or covers.

1. Keep the machine and its parts as clean as possible to prevent excessive wear and damage.
2. Remove the chip pan and dispose of the chips when necessary.
3. Metal chips and other waste materials may collect around areas such as: saw guides, table surface, T-slots, bandwheels, slides, etc. Remove these materials as soon as possible. **The DoALL Company recommends removing chip collections at least twice per each eight (8) hour shift, and more often with heavier use.**

TROUBLE SHOOTING



Repair and adjustment procedures should be made by experienced maintenance personnel, or by a DoALL Center representative. Reference to the machine's electrical schematic will be helpful.

MACHINE WON'T START

1. Make sure the disconnect switch is in the "ON" position.
2. Reset the **All Stop** pushbutton (rotate the button head **clockwise**).
3. Make sure the bandwheel doors are closed.
4. Check the circuit breakers for tripping and/or blown fuses.
5. Check the overload reset on the drive motor starter. Starting and stopping the machine a number of times in quick succession, or an overload, will trip the starter overload switch. Locate and correct the trouble, then push the overload reset switch.
6. Check the transformer for faulty operation.

MACHINE VIBRATION

1. Check for unbalanced bandwheels.
2. Check for worn or unbalanced band drive belts.
3. Check for an incorrectly shimmed machine base.

SAW BAND VIBRATION

1. Incorrect band speed is being used.
2. Choice of blade pitch is incorrect.
3. Stock is not being clamped firmly to the worktable and/or optional vise jaws.
4. Check for worn or improperly adjusted saw guide inserts.
5. Check for a worn saw guide back-up bearing.
6. Check for a loose post. Adjust the two (2) spring plungers if necessary.
7. Check for a poor weld in the saw band.
8. Check for an incorrect saw band tension setting.

SAW BAND IS CUTTING INACCURATELY

1. Check for worn blade teeth. Inserts that are too wide for the blade will damage the teeth set.
2. Check for scale on the stock.
3. The saw band may be too wide if a radius is being cut.
4. Check for incorrect saw band, post or insert alignment.
5. Incorrect band speed is being used.
6. Mist coolant (if supplied) is not being applied evenly to both sides of the saw band.
7. Check for an incorrect saw band tension setting.
8. The upper saw guide is not located close enough to the stock.
9. Check for worn or loosely-adjusted saw guide inserts.

EXCESSIVE INSERT AND BLADE WEAR

1. Inserts or roller saw guide are adjusted too tightly on the saw band.
2. High band speed is causing friction (using roller saw guides may be advisable). Increase coolant (if supplied) volume to better lubricate the saw band.
3. The back-up bearing may need replacement.
4. Check for incorrect saw band tension setting.
5. Wheel brush is worn or not properly adjusted causing chips to stay on the bandwheel.

PREMATURE BLADE TEETH DULLING

1. The saw band is not being "broken" in on the first few cuts. Reduce the feeding pressure when making these cuts.
2. Band speed is too high (this causes abrasion).
3. Saw band pitch is too coarse.
4. Mist coolant (if supplied) is not properly covering the saw band.

TROUBLE SHOOTING (Continued....)

5. The feed force is too high.
6. Check for faulty material such as heavy scale, inclusions, hard spots, etc.
7. Check for saw band vibration.
8. Check for chip welding, or for a chipped tooth lodged in the cut.
9. Check for incorrect saw band tension setting.
10. Inserts are incorrect for the width of blade being used. This allows the inserts to hit the set teeth (listen for clicking sounds during saw band operation).

SAW BAND SLIPS OFF BANDWHEEL

1. The upper and/or idler bandwheels are not aligned properly. The saw band needs to be tracked.
2. Check for slippery coolant, or excessive coolant volume (if supplied).
3. Check for incorrect machine alignment.
4. Check for a worn or improperly-adjusted wheel brush (this allows chips to remain on the bandwheel tire).
5. Incorrect saw guides are being used.
6. Check for incorrect saw band tension setting.

SURFACE FINISH ON WORK IS TOO ROUGH

1. Check for a worn saw guide insert (adjust or replace if necessary).
2. Band speed is too low or feed force is too heavy.
3. Blade pitch is too coarse.
4. Check for saw band vibration.
5. Check for a poor weld in the saw band.

NO COOLANT FLOW (If Supplied)

1. Make sure reservoir is full.
2. Check for a clogged coolant applicator nozzle.
3. Check for a clogged or kinked coolant hose.

4. Check for a clogged or damaged coolant control valve.

TRANSMISSION WILL NOT STAY IN GEAR

1. Check for worn gears.



Transmission replacement, repairs, adjustments or alignment should be performed only by a DoALL service representative.

TRANSMISSION WILL NOT SHIFT INTO GEAR

1. Check the shift linkage for loose set screws or broken spring pins.
2. Check for a jammed shift mechanism.
3. Check for jammed or damaged sliding clutch jaws.

FILE BAND BREAKS (If Supplied)

1. Band tension setting is too high. Set for the same tension as used for a 1/8 inch (3.2 mm) wide carbon saw band.
2. Feed force is too high.
3. Check for incorrect file band being used.

POOR BAND FILING FINISH (If Supplied)

1. The feed force is too high.
2. File band is not correctly assembled.
3. The saw band tension setting is too high.

ACCESSORIES



The following are accessories sometimes used during sawing operations. A DoALL sales representative will be happy to advise you about the current availability of any accessory.

DISC CUTTER

- This attachment can be used to cut internal or external circles from 2-1/2 to 30 inches (63.5 to 762.0 mm) in diameter. To set up the disc cutter:
 - Place flat washers under the mounting screws. Then: **(a)** Bolt the mounting bracket to the post; **(b)** Lower the post until the upper saw guide is approximately 3/8 inch (10 mm) above the worktable; **(c)** Loosen the fine adjustment and arm clamp bolts; **(d)** Move the center pin to the approximate distance of the radius to be cut; **(e)** Tighten the fine adjustment clamp bolt.

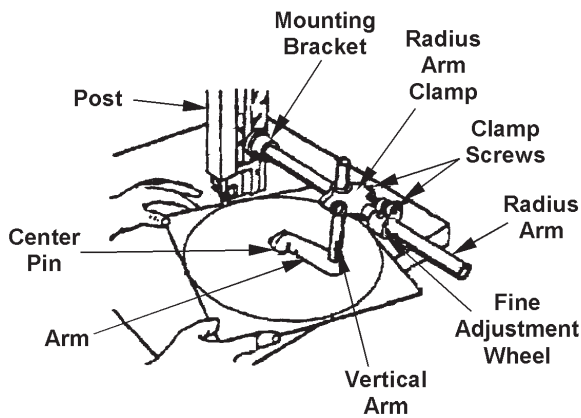

Disc Cutter.

- Position the center pin so that it is perpendicular to the saw band's cutting edge. To do so: **(a)** Place a square against the tip of a sawband tooth; **(b)** Loosen the vertical adjustment clamp bolt; **(c)** Line up the center pin with the square's blade edge; **(d)** Clamp the vertical adjustment clamp bolt.
- Make final radius adjustments with the fine adjustment wheel. Then: **(a)** tighten the arm and radius arm clamp bolts while making sure the center pin is square to the table; **(b)** Adjust the disc cutter for stock thickness by raising or lowering the post.

MITER NO. 2 CUT-OFF (Side Mount)

- To set up: **(a)** Place a combination square in the worktable sawing slot to check the alignment; **(b)** Set the bar for sawing at the desired angle. It is important that the mitering bar contact the worktable's surface evenly during use.

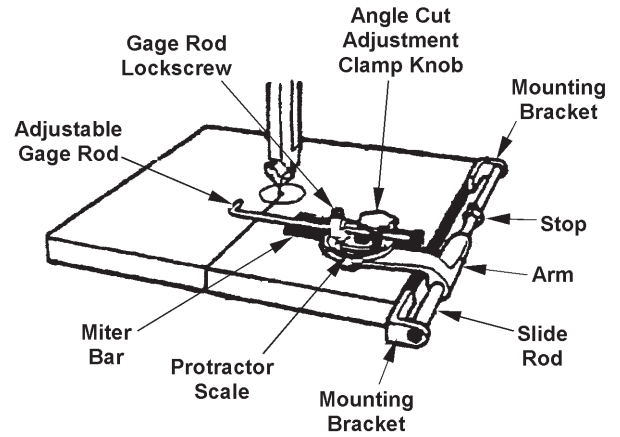

Miter No. 2 Cut-Off Option.

- When not in use, this unit can be swung upward and around on the slide rod so that it hangs down below the worktable surface.

RIP FENCE

- Square this fixture during installation so that it is in line with the worktable sawing slot. When alignment is correct, secure the adjusting screws in place with the set screws under the the guide bar on the rip fence casting.
- Before attempting a long cut, check to see that the saw band is not worn on one side. This will cause stock to wander relative to the rip fence guide bar.

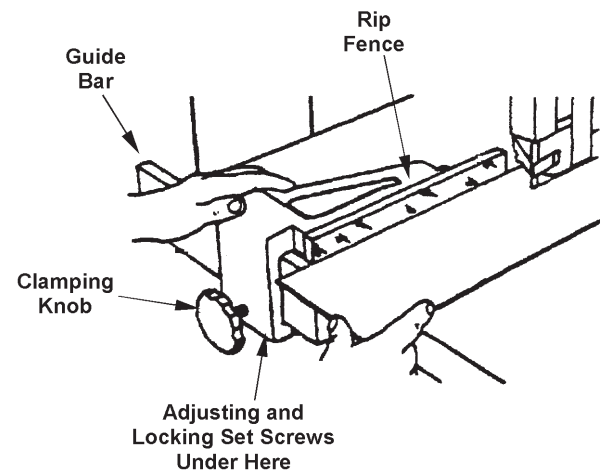

Rip Fence.

HEAVY WORK SLIDES

- This unit features metal ball bearing slide bars positioned to reduce friction between the worktable and heavy stockpieces.

HEAVY WORK SLIDES (Continued...)

- When using the work slides, replace the worktable's center plate with a center plate with an attached block to support stock at the sawing point.

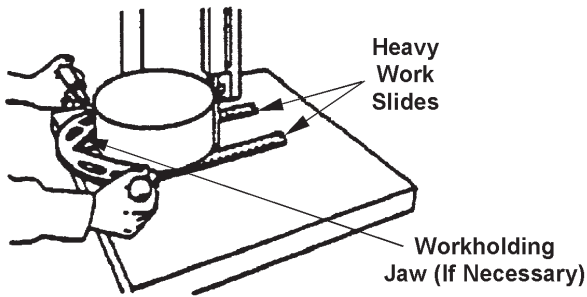

Heavy Work Slides.

WORKHOLDING JAWS

- This option is used for off-hand and contour sawing. By looping a power feed chain around the workholding jaws, the operator can use the cable pulley system to guide stock along the contour layout lines.



Be sure to use the correct saw band width when cutting a radius.

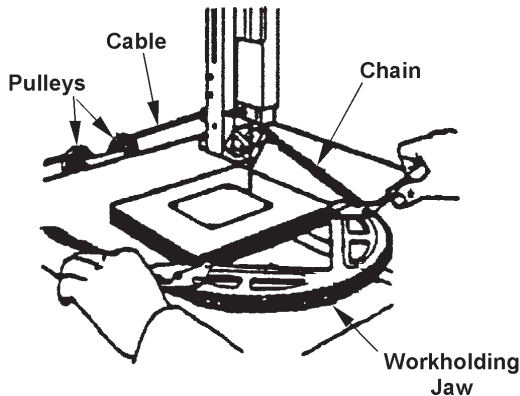

Workholding Jaws.

AIR-OPERATED POWER FEED



This option requires shop air: 20 psi (1.4 kg/cm²) minimum; 100 psi (7.0 kg/cm²) maximum. It has been tested at 70 psi (4.9 kg/cm²) pressure during factory inspection.

- Air power feed provides steady feeding pressure and allows the operator to use both hands to guide the stockpiece.
- This system has: **(a)** A pressure-regulating valve and gauge located slightly below the left worktable surface; **(b)** A pulley and cable system attached by an adjustable bracket to the rear worktable edge and to an air cylinder mounted to the machine base.

- Operation procedures are as follows:

- Adjust the pulley and cable system for stock width. This is done by: **(a)** Loosening the two (2) knobs located under the rear mounting bracket; **(b)** Removing any slack in the workholding chain.

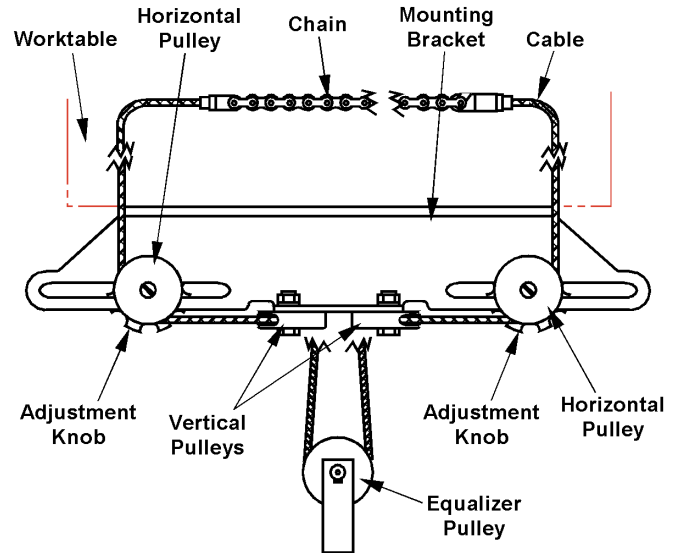

Chain and Pulley System.

- Set the desired feed force with the regulating valve knob. Turn the knob **clockwise** to increase feed force, **counterclockwise** to decrease it. Refer to the gauge for pressure readings.

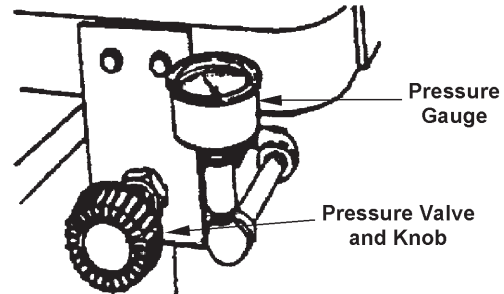

Pressure Valve and Gauge.

- Place stock between the workholding jaws and remove any slack in the cable. Next: **(a)** Start the machine; **(b)** Begin the cut by pushing down slightly on the foot pedal.
- Feed force can be increased while sawing by applying additional pressure on the foot pedal. When the sawing is finished, remove your foot from the pedal to relax feed force.



A special oil-mist lubricator is included with this option.

CHIP BLOWER

1. The operator can remove chips from the sawing area by using the chip blower. Shop air is used to deliver air to the cutting area.
2. Adjust the flexible hose and nozzle to direct chips away from the sawing area.
3. The air supply connection is located on the left side of the machine on the drive compartment wall. Incoming air supply should be between 80 and 90 psi (5.6 and 6.3 kg/cm²).



DO NOT exceed 90 psi (6.3 kg/cm²).

MIST COOLANT

1. Using shop air, this option has a valve with sight glass and a one (1) quart (0.95 liter) supply bottle mounted on the rear side of the head.
2. Air and coolant are mixed in a manifold to form a fine mist. Adjust the flexible tube to direct mist stream onto saw band and workpiece to lubricate and cool the cutting area. Regulate mist with adjustable valve at a rate of one drop per second as seen through the sight glass.
3. The air supply connection is located on the left side of the machine on the drive compartment wall. Incoming air supply should be between 80 and 90 psi (5.5 and 6.2 bar or 5.6 and 6.3 kg/cm²).



DO NOT exceed 90 psi (6.2 bar or 6.3 kg/cm²).

4. Your DoALL sales representative can provide complete information on various coolants and their applications

BAND MIST LUBRICATOR

1. See the instructions sent with the unit for information on operation and adjustments.

WORKLIGHT

1. The worklight illuminates the cutting area and areas nearby and is controlled by an "on/off" switch on the lamp, or by selector switch on the electrical control box.

MAGNIFIER

1. Magnifying the cutting area may prove helpful during delicate sawing procedures. This is done by placing a magnifying lens around the shade of the worklight.

2. A protective lens cover should be placed around the magnifier to prevent scratches when not being used.

POST ELEVATING HANDWHEEL

1. This option allows the operator to adjust the post and upper saw guide by means of a handwheel located on the right side of the sawing head. Turn the handwheel **clockwise** to "raise" the post, **counterclockwise** to "lower" it.

WORKTABLE OPTIONS

30" x 30" Worktable

1. Your machine may be equipped with a factory-installed 30 x 30 inch (762.0 x 762.0 mm) worktable in place of the standard 26 x 26 inch (660.4 x 660.4 mm) worktable. Load capacity is 500 pounds (226.8 kg).

18" Stroke Worktable

1. This factory-installed air-powered worktable has a 18 inch (457.2 mm) stroke instead of standard 12 inch (304.8 mm) stroke. The table's working surface is 24 by 36.5 inches (609.6 by 927.1 mm).

Glide Table

1. This worktable option has a 26 by 26 inch (660.4 by 660.4 mm) worktable and table travel of 10-3/4 inches (273.0 mm). It can **not** be tilted. Load capacity is 200 pounds (90.7 kg).
2. The workpiece is securely clamped to the table. The operator then holds the handle in front of the table and manually pushes the table with the workpiece through the saw band. The handle also acts as a workstop if desired.



DO NOT force workpiece through the saw band.

3. A thumbscrew located in the lower right under the worktable locks the worktable in place to allow loading and unloading of stock. Loosen the thumbscrew completely for the worktable to move freely.
4. Air power feed option can be added to assist in moving the workpiece through the saw band.
5. The handle must be removed for saw band changing.

WORKTABLE OPTIONS (Continued....)

HMD Hydraulic Table

1. This factory-installed hydraulic-powered worktable replaces the standard table. The HMD-36 table's working surface is 34 by 42 inches (863.6 by 1066.8 mm) and has a 36 inch (914.4 mm) table stroke. The HMD-60 table's working surface is 34 by 68 inches (863.6 by 1727.2 mm) with a 60 inch (1524.0 mm) table stroke.
2. Information covering installation, operation and maintenance of the optional HMD-36 or 60 table are provided in a separate instruction manual included with the machine.

AIR-POWERED WORKTABLE



This attachment reduces the machine's work height capacity by one (1) inch (25.4 mm).

1. This optional worktable provides a 24 by 30-1/2 inch (609.6 by 774.7 mm) working surface with coolant return troughs. The worktable can be tilted up to 6° left and 45° right when using this attachment. It has two (2) T-slots for work fixture clamping.

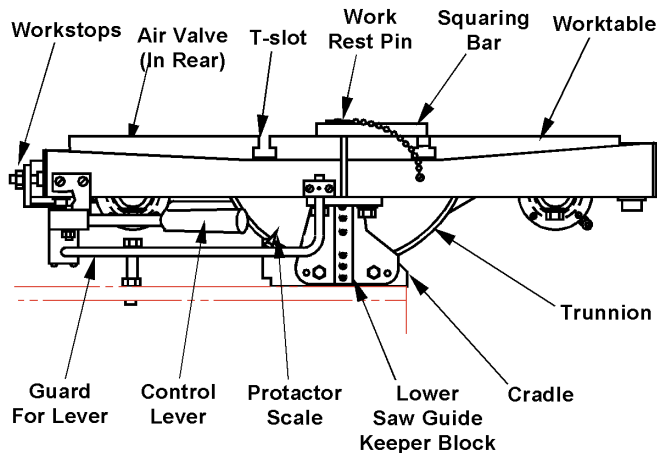

Air-Powered Worktable.

2. The worktable's air-amplified feed system is lever controlled and allows 12 inches (304.8 mm) of worktable travel. Light hand pressure against the lever will move the worktable in forward motion. Release the lever and pull back the worktable manually.
3. The worktable has a work rest pin that acts as a workstop when inserted into the sawing slot. Other worktable features are: **(a)** A squaring bar that fits into a worktable T-slot to hold stockpieces during production sawing; **(b)** Locks that permit the loading and positioning of heavy stock; **(c)** Special center plates for filing and polishing operations.

Set-Up

1. Position the workstops located on the left side of the worktable to limit travel. The front stop controls cut depth; the rear stop minimizes unnecessary travel. Stops are positioned by: **(a)** Loosening the locknuts; **(b)** Sliding the stops to the desired position; and **(c)** Tightening the locknuts.
2. To tilt the worktable: **(a)** Use the wrench provided to reach through the machine frame and under the worktable to loosen the tilt locknut; **(b)** Tilt the worktable manually until the pointer reaches desired angle shown on the scale; **(c)** Tighten the tilt locknut.

Production Sawing

1. Place the rest pin into the worktable's sawing slot to serve as a workstop. Then: **(a)** Place the squaring bar in the worktable's T-slot to act as the stock holder. **Remove the rest pin and squaring bar for contour sawing.**
2. Place stock on the worktable and secure it at the desired position. Then: **(a)** Use the control lever to carefully move the table forward until the saw band has just started cutting into the workpiece; **(b)** Push the control lever to obtain the desired feed force (feed force will return to zero (0) when the lever is released).

UNIVERSAL CALIBRATED WORK FIXTURE (Used with Air Table Option)

Set-Up for Straight Cut-Off

1. Place the fixture on the worktable at the required distance from the saw band. Then: **(a)** Loosely install T-nuts and screws; **(b)** If necessary, align the scale's zero (0) mark with the saw band, then "zero" the pointer.
2. Place socket head screws loosely in the T-nuts projecting up from below the back-up bar. Then: **(a)** Place the T-nuts in the worktable T-slots; **(b)** Slide the work fixture's back-up edge to a distance equal to the desired length of cut. Be sure to allow enough clearance for positioning the stock.

UNIVERSAL CALIBRATED WORK FIXTURE (Continued....)

- Square the back-up bar to the worktable by aligning one (1) movable workstop edge with the T-slot or edge of the table sawing slot. Then: **(a)** Line up the calibrated bar's "0" mark with the saw band; **(b)** Tighten the socket head screws so that the back-up bar is firmly anchored to the worktable.

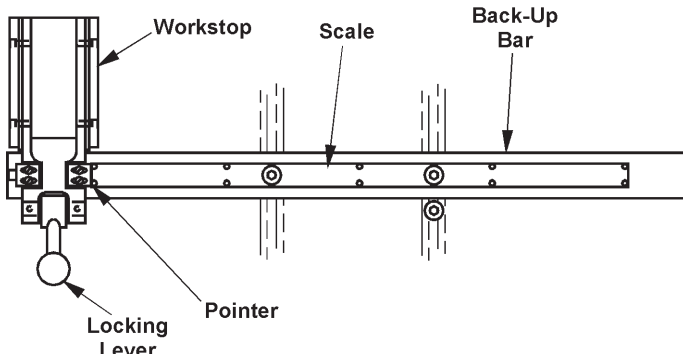

Universal Calibrated Work Fixture Set-UP for Straight Cut-Off.

- Shift the movable workstop to one side of the saw band. Then: **(a)** Run the worktable forward until the front of the workstop passes the saw band; **(b)** Move the workstop toward the saw band until its edge barely touches the set teeth.
- Close the locking lever to hold the workstop in position. Then adjust the workstop pointer until it lines up with the scale's "0" mark.

Set-Up for Angle Cut-Off

- Loosen the left socket head screw. Next: **(a)** Remove the right T-nut and screw from the back-up bar; **(b)** Use a protractor or square to position the back-up bar at the desired angle as measured to the worktable's T-slot; **(c)** Tighten the socket head screw.

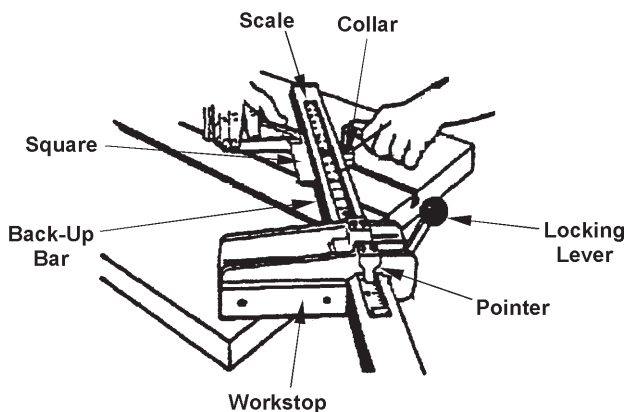

Universal Calibrated Work Fixture Set-UP for Angle Cut-Off.

- Mount the collar on the right T-nut and fasten it to the worktable (against the back-up bar) with the socket head screw. Then: **(a)** Run the worktable forward until the back-up bar barely touches the saw band; **(b)** Set the workstop for the required stock length dimension. **The back-up bar scale is not used for angle cuts.**
- Notch the back-up bar with the saw band to assure being able to cut completely through the stock. Set the worktable stop to limit travel to the length of cut.

PROTRACTOR WORKSTOP and ALIGNMENT GAGE (Used with Air Table Option)

- To set up this unit: **(a)** Lock the slide bar into the worktable T-slot so that the miter head clears the saw band; **(b)** Release the clamping handle to adjust the miter head for angle cutting between 0° and 45°.

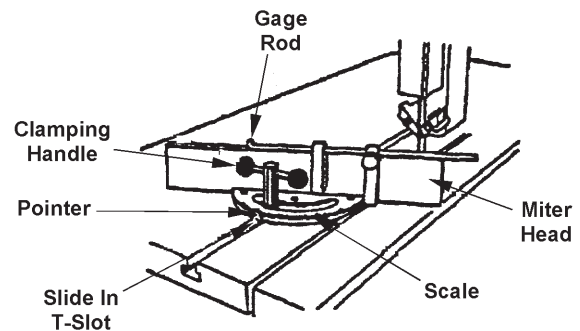

Protractor Workstop and Alignment Gage.

- Adjust for the desired cut length by loosening the gage rod thumb screw. Then: **(a)** Slide the rod to the desired position; and **(b)** Tighten the thumb screw.
- Set-up by clamping the vise jaws into the worktable's right T-slot and the cut-off gage into the left T-slot.

DBW-15 BUTTWELDER

- Information covering blade welding, plus operation and maintenance of the optional DBW-15 Buttwelder (with flash grinder and blade shear) are provided in a separate instruction manual.

OPTIONAL SAW GUIDE BLOCKS

1. It is possible to equip the machine with precision, heavy-duty, high speed, insert-type saw guides or roller saw guides.

Insert-Type Saw Guides

- High speed, heavy-duty saw guide blocks are for band speeds up to 6000 fpm (1830 m/min).

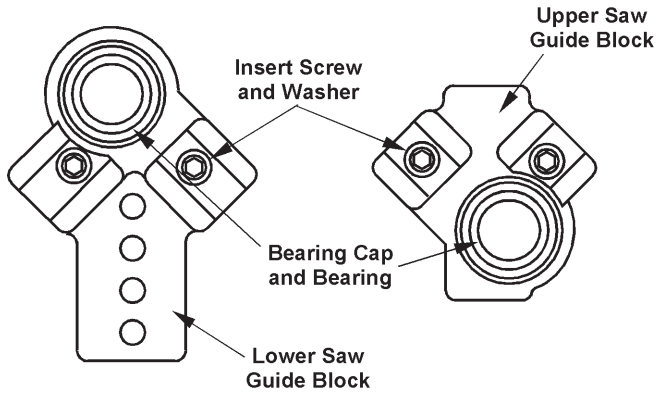

High Speed Saw Guides (Standard)

- Precision saw guide blocks are used for band speeds up to 2000 fpm (608 m/min) with saw band widths of 1/16 to 1/4 inch (1.5 to 6.4 mm).

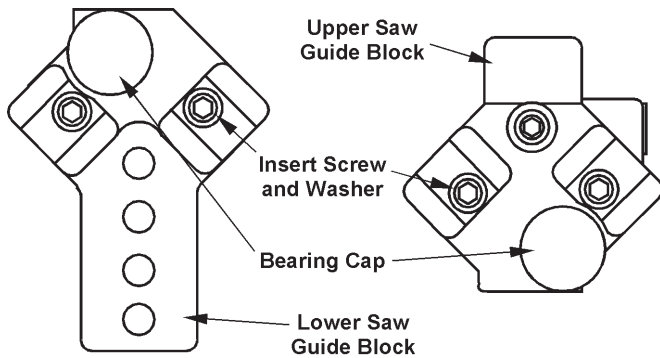

Precision Saw Guides.

- Saw guides with steel or carbide-faced back-up bearings with saw band widths of 1/16 to one (1) inch (1.5 to 25.4 mm) can be used with this machine.

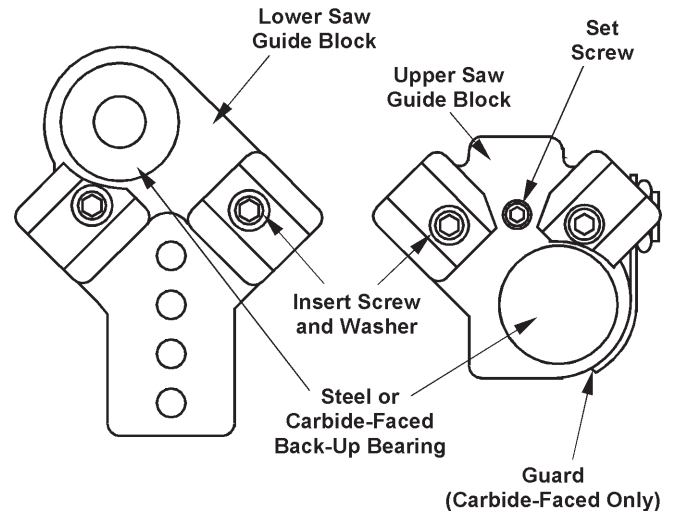

Heavy-Duty Saw Guides With Steel or Carbide-Faced Back-Up Bearing.

Roller Saw Guides

1. Use roller saw guides for continuous high-speed sawing. They are recommended for continuous sawing at band speeds over 1300 fpm (390 m/min).
- Type I roller saw guide blocks use 1/4 to 1/2 inch (6.4 to 12.7 mm) saw bands and are for band speeds up to 6000 fpm (1830 m/min).

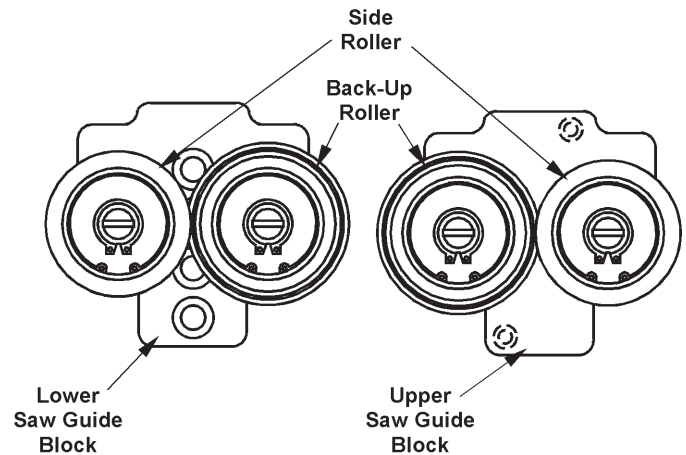

Type I Roller Saw Guides.

- Type II roller saw guide blocks use 1/4 to one (1) inch (6.4 to 25.4 mm) saw bands and are for band speeds up to 6000 fpm (1830 m/min).



Type II roller saw guide blocks reduce the work height capacity by one (1) inch (25.4 mm) and restricts right table tilt to 27°.

OPTIONAL SAW GUIDE BLOCKS (Contin-

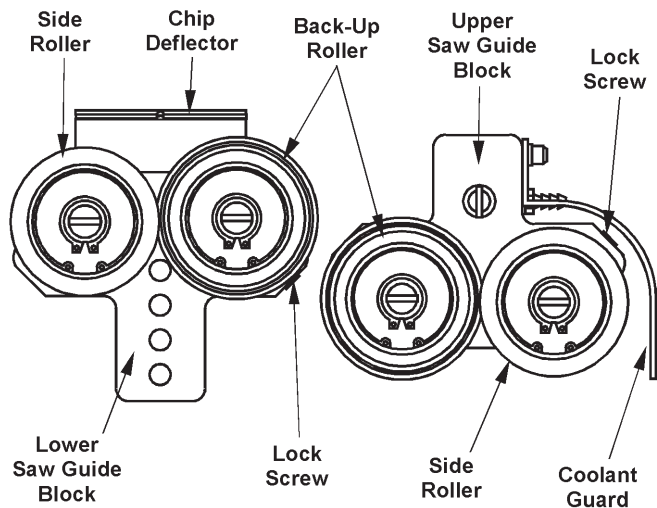

Type II Roller Saw Guides.

2. Roller saw guides are adjusted as follows:

- Select the rollers which match the width of saw band to be used. Next: **(a)** Place one (1) back-up roller (has a rear flange) and one (1) side roller in upper guide block; **(b)** Place one (1) back-up roller and one (1) side roller in the lower saw guide block in opposite position of the upper guide; **(c)** Attach the upper roller guide to the post and the lower roller guide to the keeper block.
 - Place the saw band over the upper and lower bandwheels. Next: **(a)** Adjust the saw band tension; **(b)** Loosen the roller lock screw; **(c)** Bring the rollers toward the saw band by turning the eccentric bearing shaft with a screwdriver. The rollers should be just free enough to turn without moving the saw band.
- ⚠ The bearings will overheat if the rollers are too tight against the saw band. Conversely, rollers that are too loose may cause the saw band to wobble and affect cutting accuracy.**
- Tighten the roller lock screws to prevent the eccentric shaft from turning and changing the roller adjustment.

90° SAW GUIDE BRACKETS

1. These brackets permit cutting materials longer than the machine's regular throat capacity. Install the upper and lower brackets as shown. Then the saw guide blocks are mounted to the brackets.

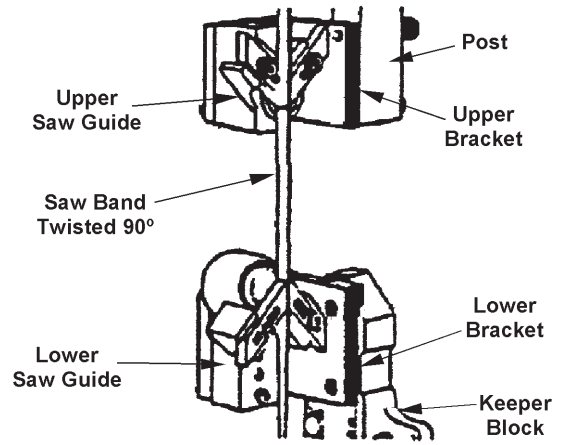

90° Saw Guide Brackets.

2. When these brackets are used, be sure to: **(a)** Install the correct size saw guides; **(b)** Install the saw band so that it is twisted 90°; when it passes through the saw guide inserts; **(c)** Operate the machine at band speeds under 1500 fpm (450 m/min).

ADJUSTABLE ANGLE SAW GUIDES

1. These saw guides allows the operator to rotate the saw band a set angle of 45° and 90° from the regular operating position.

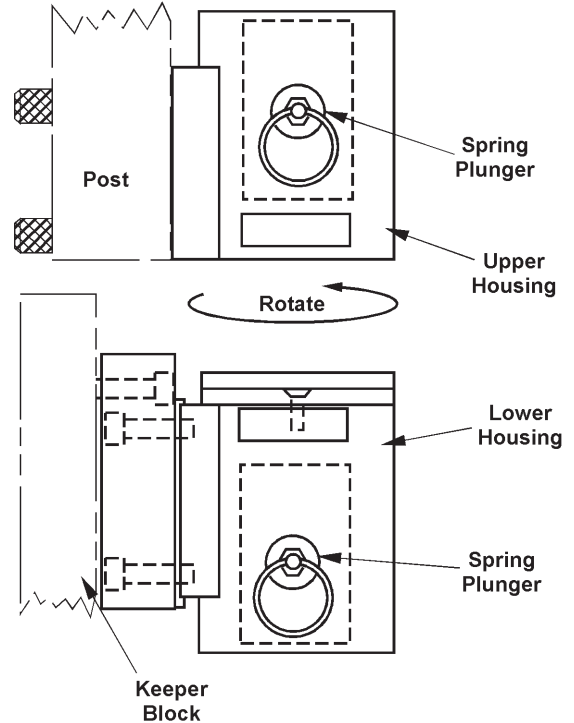

Adjustable Angle Saw Guides.

2. To adjust: **(a)** Pull the spring plunger out until it disengages; **(b)** Turn the housing to the right until it reaches the 45° preset stop until the spring plunger snaps back into place; **(c)** Turn further to the right, it will snap to the 90° preset stop. **(d)** Operate the machine at band speeds under 1500 fpm (450m/min).

DUST SPOUT

1. This option is located just below the worktable on the right side of the machine frame near the lower saw guide and attached to a collection system for disposal of chips and other waste materials.

SHIFT LOCK

1. When the saw band is running, this electrically actuated solenoid valve prevents the transmission shift lever from moving. Once the machine is off, the lever can be moved to the desired speed range.

EXTRA WORK HEIGHT

1. The factory installed extra work height allows maximum cutting capacity up to 30 inches (762.0 mm). Machines with this option have an auxiliary post support, plus a slightly different frame weldment, post guarding, and post elevating handwheel from those shown elsewhere in this manual.

BAND FILING



Band filing option is used on bandwheels with crowned rubber tires only.

1. There are standard and long file guides available. Each set consists of a file guide back-up assembly, plus 1/4 inch (6.4 mm), 3/8 inch (9.5 mm), and 1/2 inch (12.7 mm) guides.

Set-Up

1. Remove the saw band, saw guides, table center plate, and post guard. Then: **(a)** Mount the file guide back-up support to the lower keeper block; **(b)** Install the upper file guide to the post.

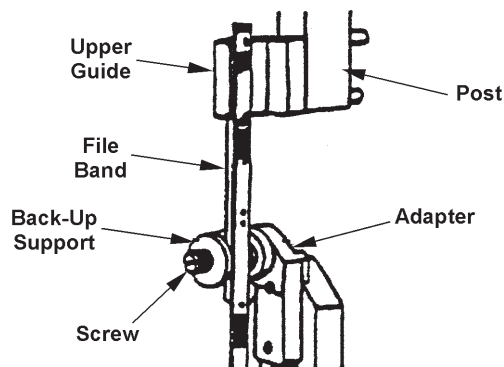

File Guide Set-Up.

2. Lower the post until it will clear the stock thickness. Post height above stock should be: **(a)** Not over two (2) inches (50.8 mm) for a 1/4 inch (6.4 mm) file band; **(b)** Not over four (4) inches (101.6 mm) for 3/8 inch (9.5 mm) and 1/2 inch (12.7 mm) file bands.

- Longer file guides permit filing seven (7) inch (177.8 mm) thick stock with a 1/4 inch (6.3 mm) file band, or eight (8) inch (203.2 mm) thick stock with 3/8 inch (9.5 mm) and 1/2 inch (12.7 mm) file bands.
3. Install the upper file guide and lock it firmly to the post with the knurled thumbscrews. Insert the special table center plate (round hole at the end of its slot).

Joining File Band

1. Place the file band around the bandwheels and insert one (1) end through the table center plate. The band's cutting edges should point downward. File length is 153 inches (3886.2 mm).
2. Hold the yellow lock rivet segment in your left hand. Then: **(a)** Depress the spring steel band tip held in the right hand; **(b)** Allow the rivet head to slip into the slotted hole and slide into the slot's small end; **(c)** Straighten the file band to allow the spring steel end to snap over the dowel.

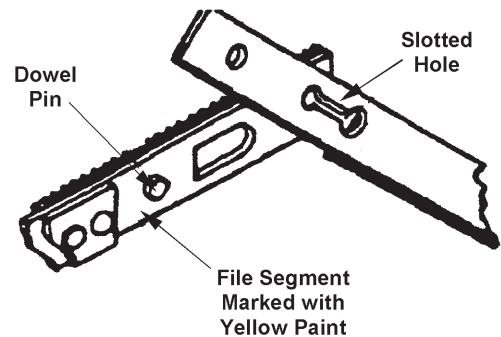

Joining File Bands.

File Band Tracking and Tensioning

1. Adjust the upper bandwheel's tilt angle (if necessary) so that the file band tracks on the center of the wheel tire. Then: **(a)** Check to see that the file band is in alignment and passing freely over the file guide supports; **(b)** Apply the same tension as indicated for a 1/8 inch (3.2 mm) wide carbon saw band. **Avoid excessive file band tensioning.**

Internal Filing Set-Up

1. Release file band tension. Next: **(a)** Remove the file band from around the bandwheels and separate it by bending the joint to approximately 12 inches (304.8 mm) radius.
2. Use your left forefinger to depress the front end of the yellow segment. Next: **(a)** Use your right thumb and forefinger to disengage the dowel; **(b)** Slide the lock rivet to the slot's open end and remove it.

BAND FILING (Continued...)

- Run the file band through the stock and reassemble it. Next: **(a)** Place the file band around the band-wheels; **(b)** Apply tension and check alignment.

Filing Operation

- Place the transmission gear shift lever in "low" range before starting the saw band drive motor.
- Keep these operating points in mind: **(a)** Keep the files clean; **(b)** DO NOT file when the teeth are loaded; **(c)** Filing can be performed without coolant application if the layout lines will be easier to follow.
- Clean the file band with a file card and coil it into no more than three (3) loops before placing it in storage.

BAND POLISHING



Band polishing option is used on bandwheels with crowned rubber tires only.

- Three (3) polishing band grain cloths belts are available in aluminum oxide:

Application	Cutting Speeds	Grit
Grinding	50-300 fpm (15-90 m/min)	50
Coarse Polishing	850-1000 fpm (260-305 m/min)	80
Fine Polishing	850-15000 fpm (260-450 m/min)	150

Polishing Belt Recommendations.

Set-Up

- Remove the table center plate. Next: **(a)** Mount the polishing band's back-up support to the post (replacing the saw guides); **(b)** Install the lower adapter to the saw guide keeper block.

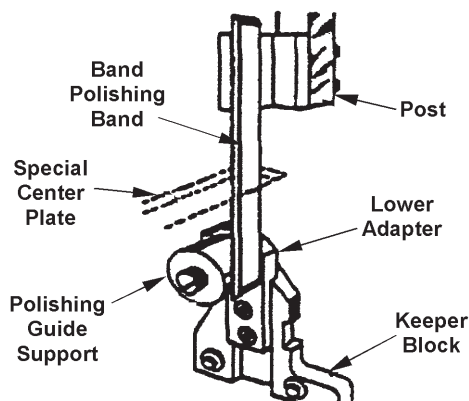

Polishing Guide Set-Up.

- Lower the post to approximately four (4) inches (101.4 mm) above the table. Then: **(a)** Mount and track the polishing band in the same manner as file bands; **(b)** Tension the polishing band in the same manner as for a 1/16 inch (1.6 mm) wide carbon saw band; **(c)** Install the special table center plate (larger slot than the standard one).
- Occasionally rub graphite powder into the polishing fabric to lubricate and increase band life. Use the air nozzle to blow away dust while polishing.



DO NOT use coolant with the band polishing option.

LASER LINE GENERATOR OPTION



To avoid eye damage, DO NOT stare into the laser beam.

- A laser device is used to emit a line on the material to be cut. This line shows the approximate spot where the cut will take place.
- The device is controlled by a selector switch with "ON" and "OFF" settings and is located on or near the control panel. Turn the laser "OFF" when not in use.
- The laser is adjustable to position the laser beam where desirable.
- When the laser is turned on, a warm-up period of 3 to 5 seconds take place before a line appears. If the line is difficult to see, darken the work area to enhance the line.
- Remove the protective shipping cap from the laser device before operation. Replace the protective cap when not in use.