

Weder die noch Herstellung dieses Dokuments, Vervielfältigung und Mitteilung dessen Inhalte, sind  
 verboten, soweit nicht ausdrücklich gestattet. Zuwiderhandlungen verpflichten zu Schadenersatz. Alle  
 Rechte für den Fall der Patent-, Gebrauchsmuster- oder Geschmacksunterzeichnung vorbehalten.  
 "Schutzvermerk nach DIN ISO 16016 beachten" Technische Änderungen vorbehalten!

Issued with CAD! Changes to be made only on the CAD/CAM modell

The reproduction, distribution and utilization of this document as well as the  
 communication of its contents to others without explicit authorization is  
 prohibited. All rights reserved in the event of the grant of a patent, utility model or design.  
 "Observe protective mark according to DIN ISO 16016" Technical data is subject to change without notice!

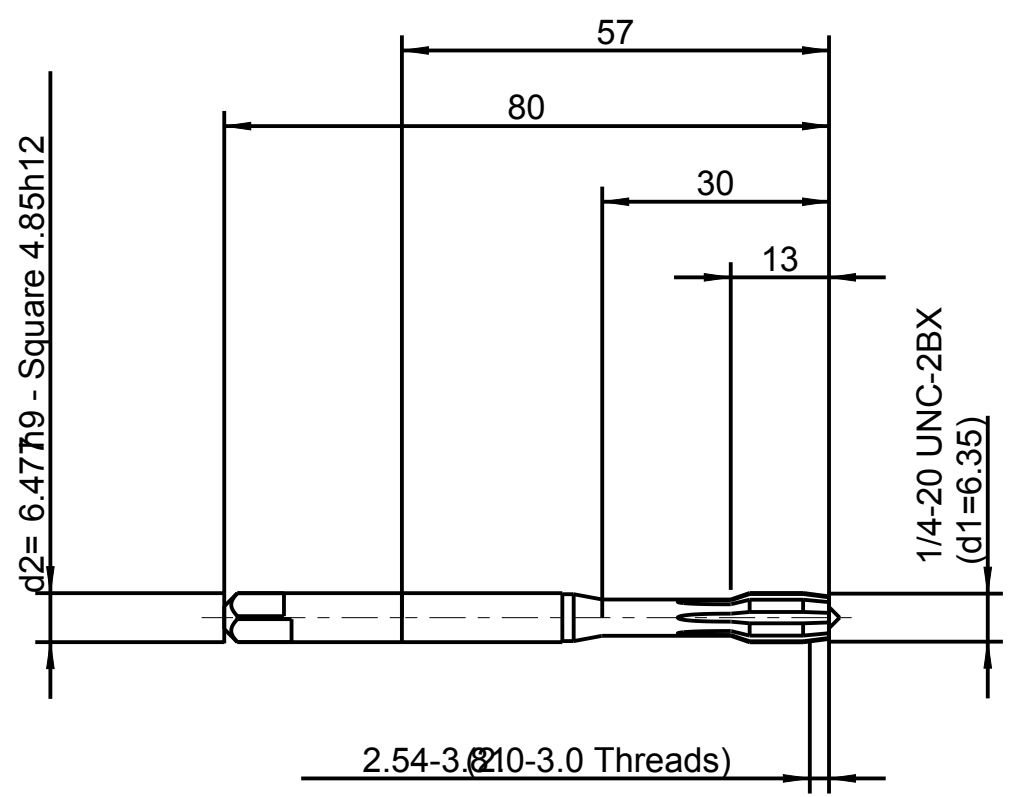

1:1

Identification

EMUGE-STEEL InnoForm1-STEEL-M-SN-TIN-66 1/4-20 UNC-2BX  
 PM Kom.-Nr.

		EMUGE-Werk Richard Glimpel GmbH & Co. KG www.emuge-franken.com		Document Type Documentary drawing													
		Description US-IF1-STEEL-M-SN-PM-TIN-66 1/4-20 UNC-2BX															
General tolerances ISO 2768-mk <table border="1"> <tr> <td>&gt;</td> <td>6</td> <td>30</td> <td>120</td> <td>400</td> <td>1000</td> </tr> <tr> <td>≤</td> <td>±0,1</td> <td>±0,2</td> <td>±0,3</td> <td>±0,5</td> <td>±0,8</td> </tr> </table>		>	6	30	120	400	1000	≤	±0,1	±0,2	±0,3	±0,5	±0,8	Sheet 1/1	View 	Customer	Component
>	6	30	120	400	1000												
≤	±0,1	±0,2	±0,3	±0,5	±0,8												
Issued by CAD/TF	Date of issue 18.05.2018	Replaced by	Material no.	Order no. BU377F00.5009													
Checked by	Date	Replacement for	Customer drawing no.	Drawing no. BU377F00.5009													

A3