

Weder die noch Herstellung dieses Dokuments, Vervielfältigung und Mitteilung seines Inhalts, sind
 verboten, soweit nicht ausdrücklich gestattet. Zuwiderhandlungen verpflichten zu Schadenersatz. Alle
 Rechte für den Fall der Patent-, Gebrauchsmuster- oder Geschmacksmarkenurteilung vorbehalten.
 "Schutzvermerk nach DIN ISO 16016 beachten" Technische Änderungen vorbehalten!

Issued with CAD! Changes to be made only on the CAD/CAM modell

The reproduction, distribution and utilization of this document as well as the
 communication of its contents to others without explicit authorization is
 prohibited. Any use of the contents of this document for advertising or
 promotional purposes, in whole or in part, is prohibited. All rights
 reserved to the extent of the patent, utility model or design.
 "Observe protective mark according to DIN ISO 16016" Technical data is subject to change without notice!

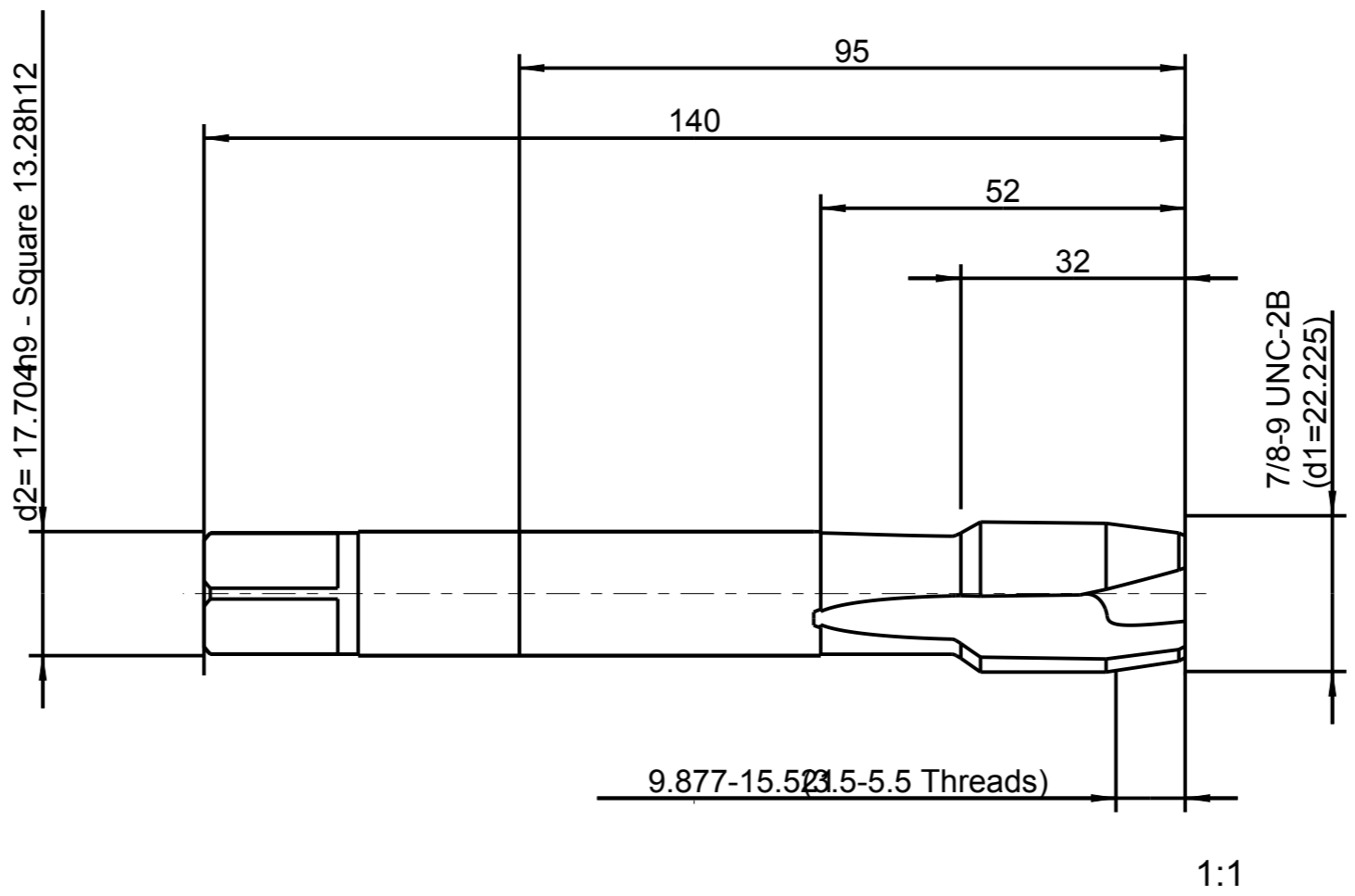

Identification

EMUGE-STEEL Rekord 2B-STEEL-L-TIN 7/8-9 UNC-2B
 Kom.-Nr.

 EMUGE-Werk Richard Glimpel GmbH & Co. KG www.emuge-franken.com		Document Type		Documentary drawing																			
		Description		US-Rek.2B-STEEL-L-TIN 7/8-9 UNC-2B																			
General tolerances ISO 2768-mk <table border="1"> <tr> <td>></td> <td>6</td> <td>30</td> <td>120</td> <td>400</td> <td>1000</td> </tr> <tr> <td>≤</td> <td>6</td> <td>30</td> <td>120</td> <td>400</td> <td>2000</td> </tr> <tr> <td></td> <td>±0,1</td> <td>±0,2</td> <td>±0,3</td> <td>±0,5</td> <td>±0,8 ±1,2</td> </tr> </table>		>	6	30	120	400	1000	≤	6	30	120	400	2000		±0,1	±0,2	±0,3	±0,5	±0,8 ±1,2	Sheet	View	Customer	Component
>	6	30	120	400	1000																		
≤	6	30	120	400	2000																		
	±0,1	±0,2	±0,3	±0,5	±0,8 ±1,2																		
Issued by	Date of issue	Replaced by	Material no.	Order no.																			
Checked by	Date	Replacement for	Customer drawing no.	Drawing no.																			
				A3																			