

SH (1/4" Steel Shank)

Carbide Rotary Files - Flame Shape

Submicron Grain Carbide

D - Double Cut

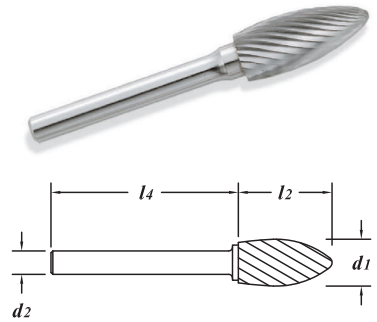

EDP#	TOOL #	$d1$ † Diameter		$d2$ Shank Diameter	$l2$ Flute Length	$l4$ Shank Length	1-11	12-24	25-49	50-100	
		Decimal	Metric								
66010	SH-2	.3125	5/16"	7.938	1/4"	3/4"	1-3/4"	13.58	12.99	12.40	11.81
66012	SH-2D	.3125	5/16"	7.938	1/4"	3/4"	1-3/4"	13.58	12.99	12.40	11.81
66020	SH-5	.5000	1/2"	12.700	1/4"	1-1/4"	1-3/4"	27.76	26.55	25.35	24.14
66022	SH-5D	.5000	1/2"	12.700	1/4"	1-1/4"	1-3/4"	27.76	26.55	25.35	24.14
66030	SH-6	.6250	5/8"	15.875	1/4"	1-7/16"	1-3/4"	36.40	34.82	33.23	31.65
66032	SH-6D	.6250	5/8"	15.875	1/4"	1-7/16"	1-3/4"	36.40	34.82	33.23	31.65
66040	SH-7	.7500	3/4"	19.050	1/4"	1-5/8"	1-3/4"	44.72	42.78	40.83	38.89
66042	SH-7D	.7500	3/4"	19.050	1/4"	1-5/8"	1-3/4"	44.72	42.78	40.83	38.89