

Use this number when searching for this item:

## 9002880050000

### Center Drill, 5mm, HSS, Uncoated

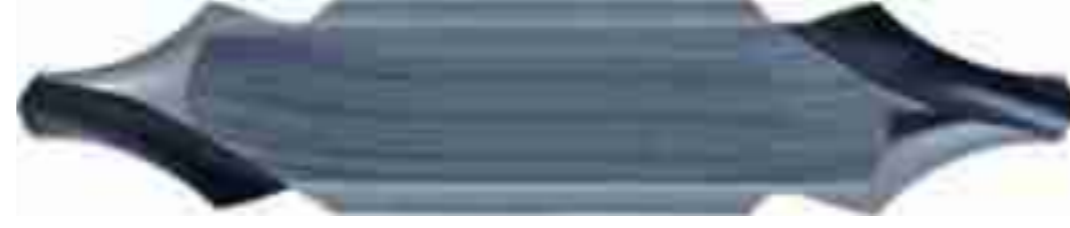

#### >> Item Info

EDP #	9002880050000
Series	288
Order Code	5.000
Coating	Uncoated
Coolant Through	No
Cutting Direction	RH
Material	HSS
Point Angle	118°
Shank	Straight
Type	Center Drill

#### >> Features

- relieved cone
- correct positioning between lathe centres
- for centre holes to DIN 332, sheet 1 (issue 09.1960x withdrawn), form R

#### >> Suggested Materials

- Aluminum
- Alloyed Steels
- Free Cutting Steels
- Tool Steels
- Stainless Steels
- Ti and Ti-alloys
- Cast Iron
- Brass
- Bronze
- Copper
- Magnesium
- Special Alloys
- Plastic
- Hardened Steels

#### >> Technical Specs

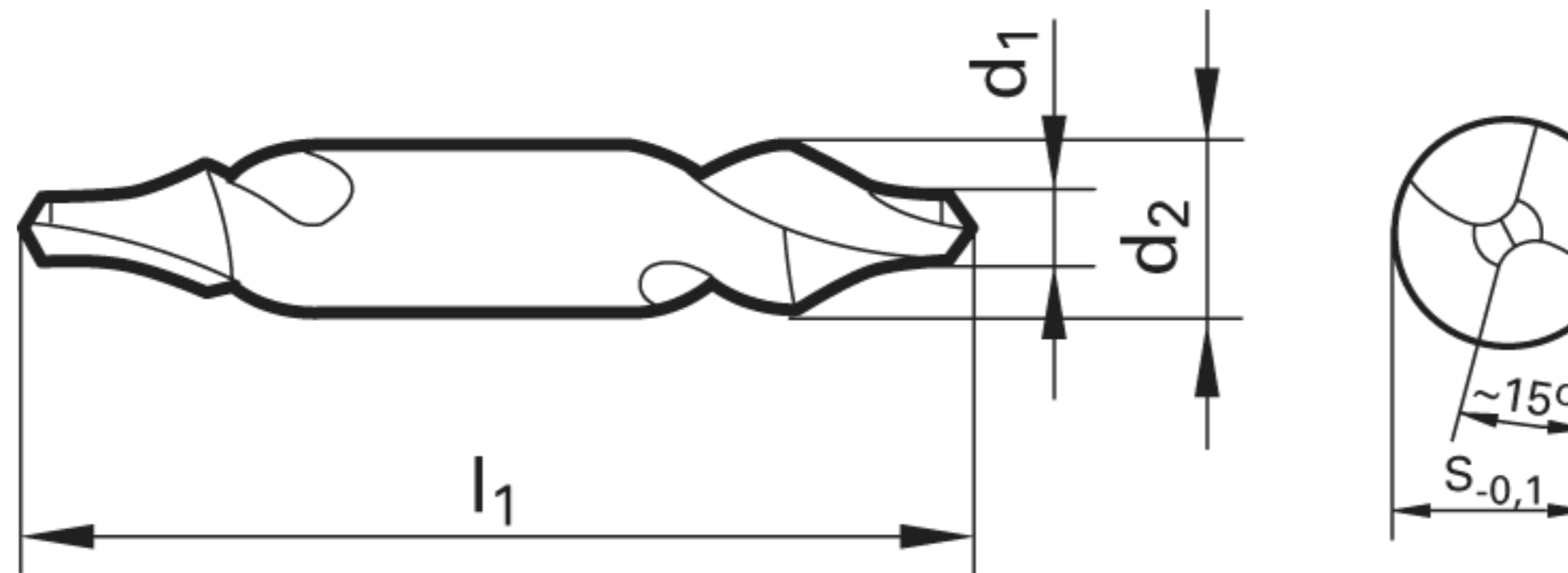

EDP #	Code No.	Cut Ø		Cut Ø		Shank Ø	OAL	Flute Length	Drilling Depth		Shank Type	Flutes
		d1	d1	d1	d1				tmax	tmax		
		mm	inch	frac.	wire / letter				mm	inch		
9002880050000	5.000	5.000	0.1969			16.000	71.00	25.00	17.50	0.689	Straight	2

\*\*\* DISCLAIMER: Data on this PDF is subject to change at any time without notice.