

Use this number when searching for this item:

9005870025000

Center Drill, 2.5mm, HSS, Uncoated



>> Item Info

| | |
|-------------------|---------------|
| EDP # | 9005870025000 |
| Series | 587 |
| Order Code | 2.500 |
| Coating | Uncoated |
| Coolant Through | No |
| Cutting Direction | RH |
| Material | HSS |
| Point Angle | 118° |
| Shank | Straight |
| Type | Center Drill |

>> Features

- relieved cone
- for centre holes to DIN 332, part 1, form A
- without protective countersink

>> Suggested Materials

- Aluminum
- Alloyed Steels
- Free Cutting Steels
- Tool Steels
- Stainless Steels
- Ti and Ti-alloys
- Cast Iron
- Brass
- Bronze
- Copper
- Magnesium
- Special Alloys
- Plastic
- Hardened Steels

>> Technical Specs

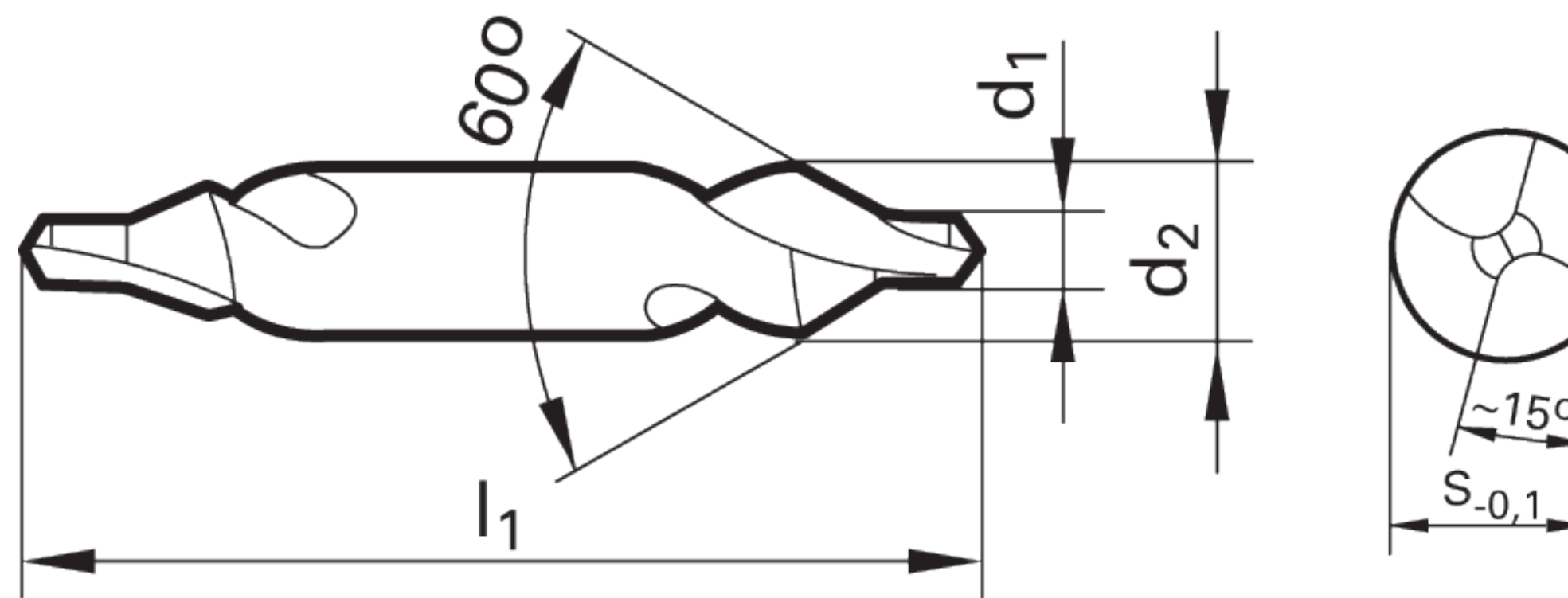

| EDP # | Code No. | Cut Ø | | Cut Ø | | Shank Ø | OAL | Flute Length | Drilling Depth | Drilling Depth | Shank Type | Flutes |
|---------------|----------|-------|--------|-------|---------------|---------|-------|--------------|----------------|----------------|------------|--------|
| | | d1 | d1 | d1 | d1 | d2 | l1 | l2 | tmax | tmax | | |
| | | mm | inch | frac. | wire / letter | mm | mm | mm | mm | inch | | |
| 9005870025000 | 2.500 | 2.500 | 0.0984 | | | 6.300 | 45.00 | 14.00 | 10.25 | 0.404 | Straight | 2 |

*** DISCLAIMER: Data on this PDF is subject to change at any time without notice.