

Metric clamping sleeve pinlock set for HPC clamping chucks

Product information

- PinLock clamping sleeve kit
- Type P denotes sleeves with PinLock design with pull-out protection
- for use with HPC clamping chucks
- for tool shank tolerance h6

Scope of delivery

- PinLock clamping sleeve (Guhring no. 4302 Type P), locking pins and assembly tool (end mill not included)

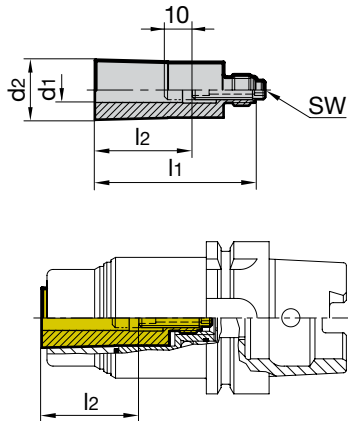

GÜHROJET
PINLOCK

Series Number

4211

**Nominal size	for shank Ø d1 h6 inch	d2 mm	l1 mm	l2 mm	Type (P = PinLock)	SW	Order Code	EDP Numbers
20	6	24.6	66	36	P	4	6.120	9042110061200
20	8	24.6	66	36	P	4	8.120	9042110081200
20	10	24.6	66	40	P	4	10.120	9042110101200
20	12	24.6	66	45	P	4	12.120	9042110121200
20	14	24.6	66	45	P	4	14.120	9042110141200
20	16	24.6	66	48	P	4	16.120	9042110161200
25	16	39	87.5	48	P	4	16.125	9042110161250
25	20	39	87.5	50	P	4	20.125	9042110201250
25	22	39	87.5	50	P	4	22.125	9042110221250
25	25	39	87.5	56	P	4	25.125	9042110251250

**HPC chuck bore nominal size must match clamping sleeve nominal size