

## Inch clamping sleeve pinlock set for HPC clamping chucks

### Product information

- PinLock clamping sleeve kit
- Type P denotes sleeves with PinLock design with pull-out protection
- for use with HPC clamping chucks
- for tool shank tolerance h6

### Scope of delivery

- PinLock clamping sleeve (Guhring no. 4236 Type P), locking pins and assembly tool (end mill not included)

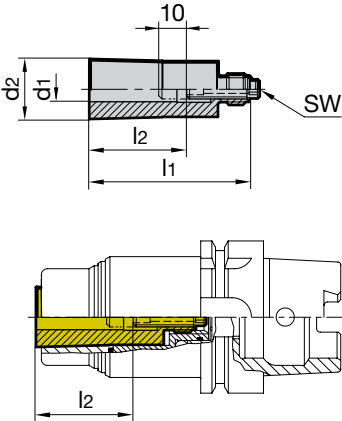

**GÜHROJET**  
**PINLOCK**

Series Number **4212**

**Nominal size	for shank Ø d1 h6 inch	d2 mm	l1 mm	l2 mm	Type (P = PinLock)	SW	Order Code	EDP Numbers
20	1/2"	24,6	66	45	P	4	1.120	9042120011200
20	5/8"	24,6	66	48	P	4	2.120	9042120021200
25	3/4"	39	87,5	50	P	4	1.125	9042120011250
25	1"	39	87,5	56	P	4	2.125	9042120021250

\*\*HPC chuck bore nominal size must match clamping sleeve nominal size