

# Whistle Notch MAS/BT side lock holders

## Product information

- balancing quality: G6.3 / 15,000 rev./min
- for tool shank tolerance h6
- MAS/BT to JIS B 6339 form AD/B
- with bore to DIN 1835-2 form E „Whistle-Notch“
- from bore d1 = 25 with two clamping screws
- coolant supply form AD/B  
(\*: BT50 version AD without coolant supply over collar)

## Scope of delivery

- incl. clamping screw Guhring no. 4903 and adjustment screw
- order pull studs, Guhring no. 4927 or 4928 separately

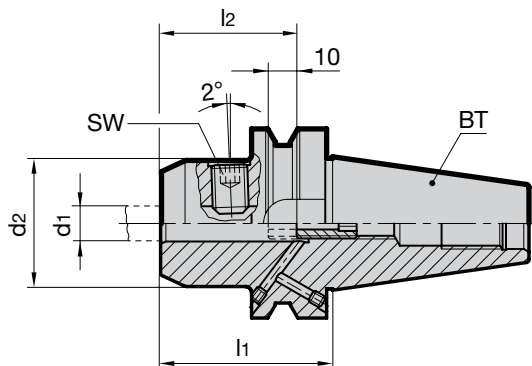

Series Number **4233**

BT	clamping-Ø d <sub>1</sub> mm	d <sub>2</sub> mm	l <sub>1</sub> mm	l <sub>2</sub> mm	SW	Order Code	EDP Numbers
40	6	25	50	36	3	6.040	9042330060400
40	8	28	50	36	4	8.040	9042330080400
40	10	35	63	40	5	10.040	9042330100400
40	12	42	63	45	6	12.040	9042330120400
40	14	44	63	45	6	14.040	9042330140400
40	16	48	63	48	6	16.040	9042330160400
40	18	50	63	48	6	18.040	9042330180400
40	20	52	63	50	8	20.040	9042330200400
40	25	63	90	56	10	25.040	9042330250400
40	32	72	100	60	10	32.040	9042330320400
50*	6	25	63	36	3	6.050	9042330060500
50*	8	28	63	36	4	8.050	9042330080500
50*	10	35	63	40	5	10.050	9042330100500
50*	12	42	80	45	6	12.050	9042330120500
50*	14	44	80	45	6	14.050	9042330140500
50*	16	48	80	48	6	16.050	9042330160500
50*	18	50	80	48	6	18.050	9042330180500
50*	20	52	80	50	8	20.050	9042330200500
50*	25	65	100	56	10	25.050	9042330250500
50*	32	72	105	60	10	32.050	9042330320500