

# Modul 4x4 hydraulic chuck flange

## Product information

- for the highly accurate radial and axial alignment on alignment adaptors or machine spindles
- cooling lubricant without loss and flow-disruption thanks to the use of an intermediate tube
- balancing quality G6.3 / 15,000 rev./min
- for tool shank tolerance h6

## Scope of delivery

- incl. adjustment screw Guhring no. 4941 for conventional cooling
- incl. angular alignment set Guhring no. 4715
- incl. 4 clamping screws
- incl. hexagon chuck key Guhring no. 4912
- order intermediate tube Guhring no. 4716 separately
- for other clamping  $\varnothing$  apply reduction bushes Guhring no. 4368 or 4369
- MQL version on request

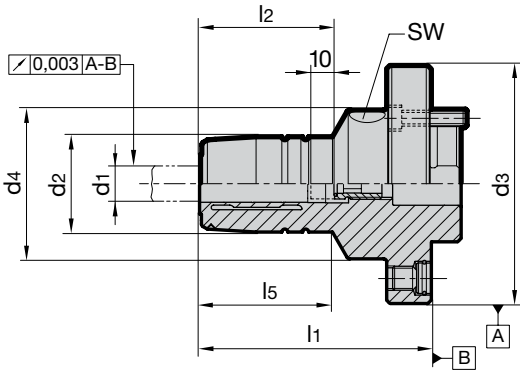

Series Number **4360**

Module- $\varnothing d_3$ mm	for shank $\varnothing d_1$ h6 mm	$d_2$ mm	$d_4$ mm	$l_1$ mm	$l_2$ mm	$l_5$ mm	incl. setting screw Guh. no. 4941	intermediate sleeve tube Guhring no. 4716	SW	Order Code	EDP Numbers
70	12	32	40	75	45	45	<b>9049410121000</b>	<b>9047160140200</b>	4	12.070	<b>9043600120700</b>
80	12	32	50	77.5	45	44	<b>9049410121000</b>	<b>9047160140500</b>	5	12.080	<b>9043600120800</b>
80	20	42	50	82.5	50	51.5	<b>9049410201000</b>	<b>9047160140400</b>	5	20.080	<b>9043600200800</b>
100	32	64	64	103	60	84	<b>9049410321000</b>	<b>9047160140200</b>	6	32.100	<b>9043600321000</b>