

GÜHROJET HSK-A milling arbors

Product information

- to hold face milling cutters
- balancing quality: G6.3 / 15,000 rev./min
- to DIN 69882-3
- for centralised or decentralised internal cooling, therefore process and tool life improvement
- bore-Ø 40 mm has four additional holes with internal thread for milling heads with tool attachment DIN 2079 and increased tight fitting diameter D2

Scope of delivery

- incl. milling retainer screw Guhring no. 4908 and driving keys

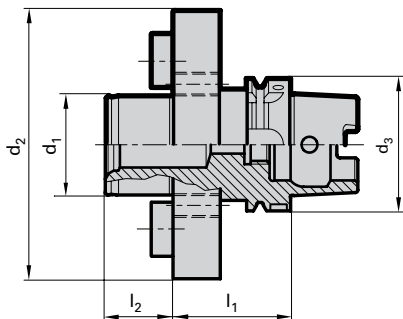

GÜHROJET

Series Number

4362

HSK-A d_3	arbor-Ø d_1 mm	d_2 mm	l_1 mm	l_2 mm	kg	Order Code	EDP Numbers
63	22	50	50	19	1.1	22.063	9043620220630
63	27	60	60	21	1.3	27.063	9043620270630
63	32	78	60	24	1.5	32.063	9043620320630
63	40	120	60	27	2.7	40.063	9043620400630
63	40	89	60	27	2.7	140.063	9043621400630
80	27	60	50	21	1.8	27.080	9043620270800
80	32	78	50	24	2.1	32.080	9043620320800
80	40	120	60	27	3.3	40.080	9043620400800
80	40	89	60	27	3.3	140.080	9043621400800
80	60	160	70	40	6.3	60.080	9043620600800
100	27	60	50	21	2.9	27.100	9043620271000
100	32	78	50	24	3.3	32.100	9043620321000
100	40	120	60	27	4.2	40.100	9043620401000
100	40	89	60	27	4.2	140.100	9043621401000
100	60	160	70	40	7.2	60.100	9043620601000