

HSK adaptors for turning centres

Product information

- for fixed tools
- incl. setting element to eliminate drive play with vertical tools
- for the transferable torsional moment the interface between spindle and flange has to be taken into consideration.
- for conventional cooling from 6 to max. 80 bar

Scope of delivery

- incl. clamping set, Guhring no. 4554
- incl. brass lock ring Guhring no. 4953
- incl. indexing pin and retention screws

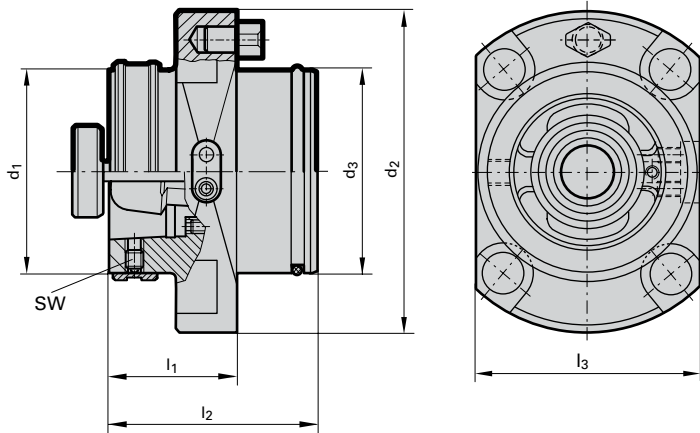

Series Number **4582**

HSK-C d ₁	d ₂ mm	d ₃ mm	l ₁ mm	l ₂ mm	l ₃ mm	SW	kg	Version	Order Code	EDP Numbers
50	84	50	35	55	55	4	0.98	l-h	38.100	9045820381000
50	84	50	35	55	55	4	0.98	r-h	38.200	9045820382000
63	100	63	40	64.5	70	5	1.74	l-h	48.100	9045820481000
63	100	63	40	64.5	70	5	1.74	r-h	48.200	9045820482000

Short HSK spindle adaptors (integrated)

Product information

- with larger axial plane
- for the transferable torsional moment the interface between spindle and flange has to be taken into consideration.
- for conventional cooling from 6 to max. 80 bar

Scope of delivery

- incl. clamping set, Guhring no. 4554
- incl. brass lock ring Guhring no. 4953
- incl. threaded pin Guhring no. 4551 and tensioning screws

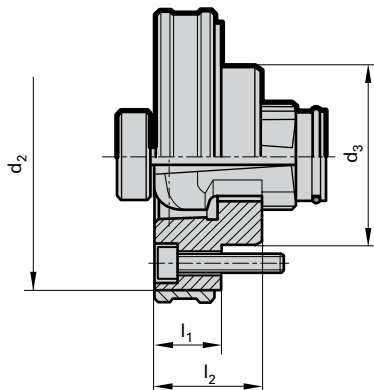

Series Number **4584**

HSK-C	d ₂ mm	d ₃ mm	l ₁ mm	l ₂ mm	SW	kg	Order Code	EDP Numbers
32	40	27	12.5	21.1	2.5	0.16	24.000	9045840240000
40	50	33.5	15	25.7	3	0.28	30.000	9045840300000
50	63	42	17.5	32.1	4	0.55	38.000	9045840380000
63	80	55	22.5	40.05	5	1.14	48.000	9045840480000
80	100	68	27.5	51.4	6	2.2	60.000	9045840600000
100	125	88	30	64	8	4	75.000	9045840750000