

Modul 6x6 shrink fit chuck flange

Product information

- for the highly accurate radial and axial alignment on alignment adaptors or machine spindles
- cooling lubricant without loss and flow-disruption thanks to the use of an intermediate tube
- balancing quality G6.3 / 15,000 rev./min
- for tool shank tolerance h6
- with axial damping screw for optimal concentricity

Scope of delivery

- incl. adjustment screw with axial force
- damping Guh. no. 4941
- incl. 6 angular alignment sets Guhring no. 4715
- incl. 6 clamping screws
- order intermediate tube Guhring no. 4716 separately
- further dimensions on request

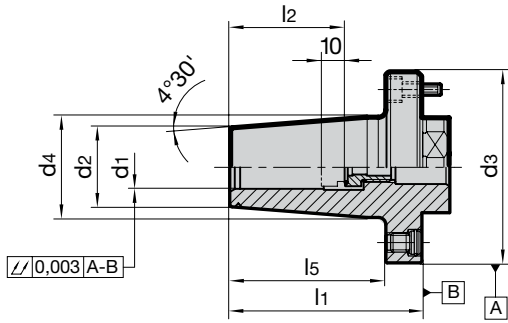

Series Number **4717**

Module- Ø d ₃ mm	for shank Ø d ₁ h6 mm	d ₂ mm	d ₄ mm	l ₁ mm	l ₂ mm	l ₅ mm	incl. setting screw Guh. no. 4941	intermediate sleeve tube Guhring no. 4716	Order Code	EDP Numbers
60	6	21	27	70	36	56	9049410061000	9047160140100	6.060	9047170060600
60	8	21	27	70	36	56	9049410081000	9047160140100	8.060	9047170080600
60	10	24	32	70	40	56	9049410101000	9047160140200	10.060	9047170100600
60	12	24	32	70	45	56	9049410121000	9047160140300	12.060	9047170120600
70	12	24	32	75	45	60	9049410121000	9047160140200	12.070	9047170120700
70	14	27	34	75	45	60	9049410141000	9047160140200	14.070	9047170140700
70	16	27	34	75	48	60	9049410161000	9047160140400	16.070	9047170160700
80	18	33	42	80	48	65	9049410181000	9047160140500	18.080	9047170180800
80	20	33	42	80	50	65	9049410201000	9047160140400	20.080	9047170200800
100	25	44	52	80	56	61	9049410251000	9047160200100	25.100	9047170251000
100	32	44	52	80	60	61	9049410321000	9047160200200	32.100	9047170321000