

GÜHROCLAMP MQL 4-point clamping sets for MQL and IC

Product information

- for radial manual HSK tool clamping
- universal application for MQL and high-pressure IC
- the central and coaxial MQL supply with constant internal diameter prevents coolant from consolidating to DIN 69090-2
- For a coolant pressure up to 160 bar

Scope of delivery

- complete as shown in illustration
- Installation and operating instructions



GÜHROCLAMP

Series Number **4930**

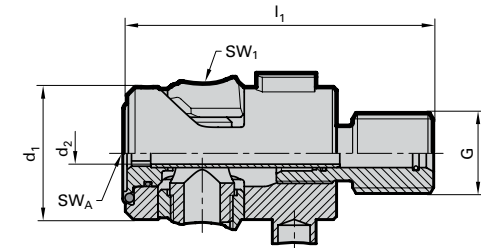

for HSK-C	d ₁ mm	d ₂ mm	l ₁ mm	G	SW1	SW _A	kg	Order Code	EDP Numbers
32	16.7	3	39.5	M10	2.5	3	0.05	24.100	9049300241000
40	20.6	4	49.5	M12	3	4	0.09	30.100	9049300301000
50	25.5	5	59	M16	4	5	0.18	38.100	9049300381000
63	33	6	76	M20	5	6	0.37	48.100	9049300481000
80	41	8	98	M24	6	8	0.7	60.100	9049300601000
100	52	10	117.5	M24	8	10	1.3	75.100	9049300751000

GÜHROCLAMP component parts for MQL 4-point clamping sets Guhring no. 4930

- retention screw only for adaptor
- If spindle cannot be locked, please use torque socket Guhring no. 4963

GÜHROCLAMP

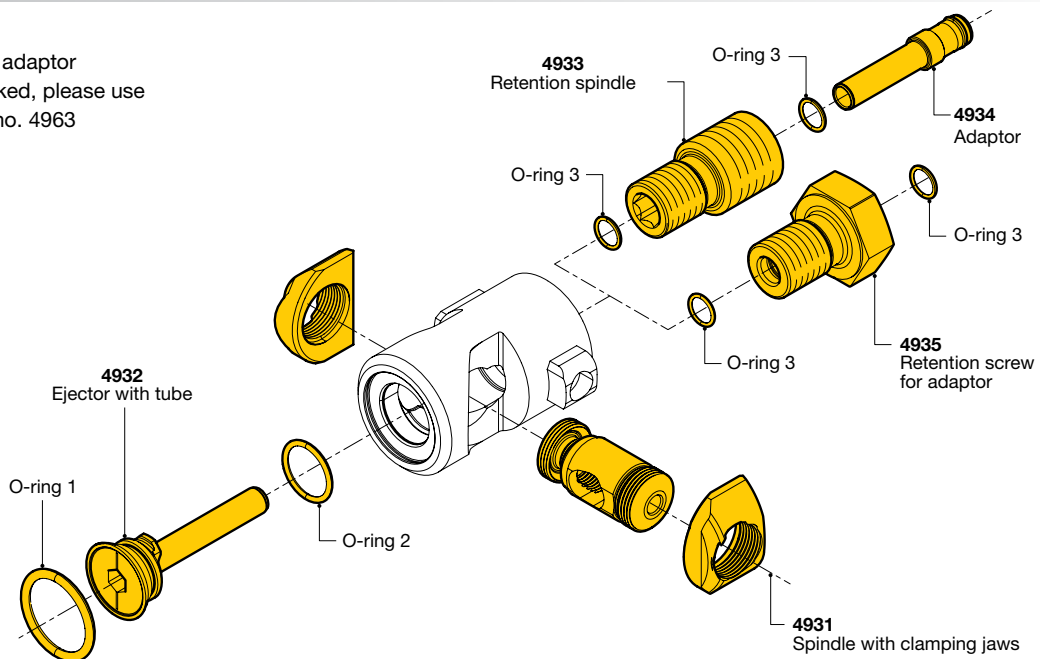

Series Number **4931** **4932**

for HSK-C	O-ring 1 NBR 70	O-ring 2 NBR 70	O-ring 3 NBR 70	Spindle with clamping jaws	EDP Numbers	Ejector with tube	EDP Numbers
32	10.82x1.78	6.0x1.5	-	24.000	9049310240000	24,100	9049320241000
40	13.0x2.0	7.0x1.5	4.5x1.0/5.0x1.0	30.000	9049310300000	30,100	9049320301000
50	16.0x2.0	10.0x1.5	5.5x1.0/7x1.0	38.000	9049310380000	38,100	9049320381000
63	20.3x2.4	14.0x1.5	7.0x1.0	48.000	9049310480000	48,100	9049320481000
80	24.0x3.0	16.0x2.0	10.0x1.5	60.000	9049310600000	60,100	9049320601000
100	31.34x3.53	22.0x2.0	12.0x1.70	75.000	9049310750000	75,100	9049320751000