

Use this number when searching for this item:

9056120115000

Drill, 11.5mm 7xD, RT 100 U, Carbide, nano-FIREX, Coolant through



>> Item Info

| | |
|-------------------|---------------|
| EDP # | 9056120115000 |
| Series | 5612 |
| Order Code | 11.500 |
| Coating | nano-FIREX |
| Coolant Through | Yes |
| Cutting Direction | RH |
| Drilling Depth | 7xD |
| Material | Carbide |
| Point Angle | 140° |
| Shank | HE |
| Type | RT 100 U |
| Tolerance | m7 |

>> Features

- facet point grind
- main cutting edge form straight
- optimized cutting geometry

>> Suggested Materials

- Aluminum
- Alloyed Steels
- Free Cutting Steels
- Tool Steels
- Stainless Steels
- Ti and Ti-alloys
- Cast Iron
- Brass
- Bronze
- Copper
- Magnesium
- Special Alloys
- Hardened Steels

>> Technical Specs

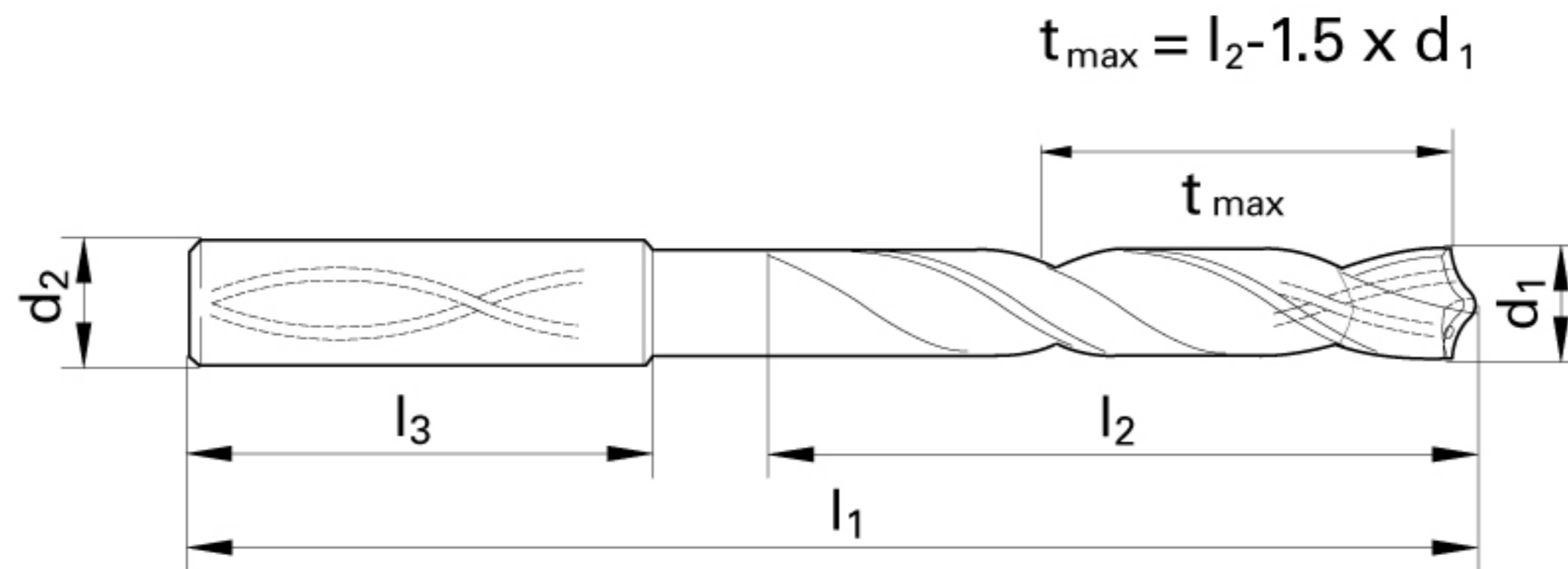

| EDP # | Code No. | Cut Ø | Cut Ø | Cut Ø | Cut Ø | Shank Ø | OAL | Flute Length | Drilling Depth | Drilling Depth | Shank Length | Shank Type | Flutes |
|---------------|----------|--------|--------|-------|---------------|---------|--------|--------------|----------------|----------------|--------------|---------------|--------|
| | | d1 | d1 | d1 | d1 | d2 | l1 | l2 | tmax | tmax | l3 | | |
| | | mm | inch | frac. | wire / letter | mm | mm | mm | mm | inch | mm | | |
| 9056120115000 | 11.500 | 11.500 | 0.4528 | | | 12.00 | 163.00 | 114.00 | 96.75 | 3.809 | 45.00 | whistle notch | 2 |



WARNING:
This product contains Cobalt, a chemical known to the State of California to cause cancer. For more information go to www.P65Warnings.ca.gov

*** **DISCLAIMER:** Data on this PDF is subject to change at any time without notice.