

Use this number when searching for this item:

## 9085220099200

Drill, 25/64 7xD, RT 100 HF, Carbide, nano-Si, Coolant through



### >> Item Info

EDP #	9085220099200
Series	8522
Order Code	9.920
Coating	nano-Si
Coolant Through	Yes
Cutting Direction	RH
Drilling Depth	7xD
Material	Carbide
Point Angle	140°
Shank	HA
Type	RT 100 HF
Tolerance	m7

### >> Features

- relieved cone
- main cutting edge is slightly concave
- optimized cutting geometry
- double margin

### >> Suggested Materials

- Tool Steels
- Ti and Ti-alloys
- Special Alloys
- Hardened Steels

### >> Technical Specs

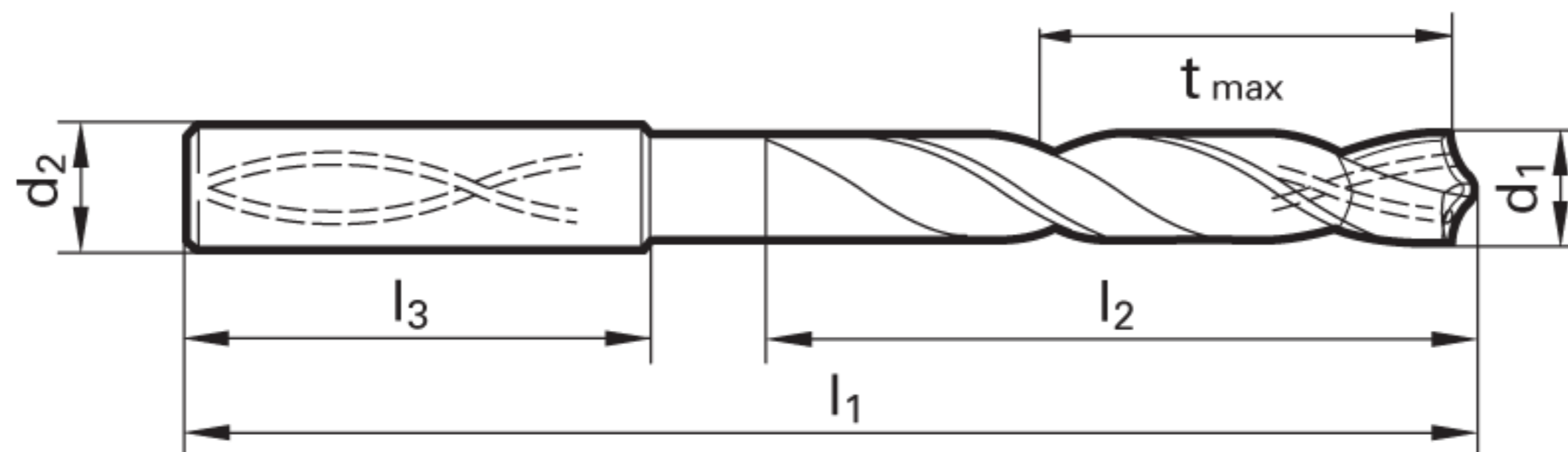

EDP #	Code No.	Cut Ø				Shank Ø	OAL	Flute Length		Drilling Depth		Shank Length	Shank Type	Flutes
		d1	d1	d1	d1			l2	tmax	tmax	l3			
		mm	inch	frac.	wire / letter			mm	mm	mm	mm			
9085220099200	9.920	9.920	0.3906	25/64		10.00	139.00	95.00	80.12	3.154	40.00	Straight	2	



**WARNING:**  
This product contains Cobalt, a chemical known to the State of California to cause cancer. For more information go to [www.P65Warnings.ca.gov](http://www.P65Warnings.ca.gov)

\*\*\* **DISCLAIMER:** Data on this PDF is subject to change at any time without notice.