

MILWAUKEE BRANCH OFFICES/SERVICE CENTERS

ARIZONA

Phoenix 85004
405 E. Watkins St.
(602) 256-7210

CALIFORNIA

(Los Angeles)
Anaheim 92801
1130 N. Magnolia St.
(714) 827-3970
(213) 624-7615
(213) 860-0349

(San Francisco)

S. San Francisco 94080
179 Utah Ave.
(415) 583-8484
S.F. (415) 761-2851

COLORADO

Denver 80219
2650 West 2nd Ave.
(303) 922-1163

FLORIDA

Miami 33122
8101 N.W. 33rd St.
(305) 592-0442

GEORGIA

(Atlanta)
Chamblee 30341
2381 John Glenn Dr.
(404) 455-7300

ILLINOIS

(Chicago)
Niles 60714
5629 Howard St.
Chicago (312) 539-9173
Niles (708) 647-8407

LOUISIANA

(New Orleans)
Harahan 70123
5610 Jefferson Hwy.
(504) 733-8543

MASSACHUSETTS

(Boston)
Newton 02158
143 California St.
(617) 244-4483

MICHIGAN

(Detroit)
Auburn Hills 48326
1120 Doris Road
(313) 373-3800

MINNESOTA

(Minneapolis)
Bloomington 55435
4350 W. 78th St.
(612) 835-4910

MISSOURI

Kansas City 64120
1506 N. Topping
(816) 241-7300

NEW YORK

(New York)
Woodside 11377
27-07 Brooklyn-Queens
Expressway West
N.Y. (718) 721-5151
N.J. (201) 622-7752

OHIO

(Cincinnati)
Sharonville 45241
11909 Tramway Dr.
(513) 733-3334

Cleveland 44125
7600 Wall St.
(216) 524-8040

PENNSYLVANIA

(Philadelphia)
Broomall 19008
388 Reed Road
(215) 544-5544

TEXAS

Dallas 75247
400 W. Mockingbird Ln.
(214) 637-4820

Houston 77007

4801 Katy Freeway
(713) 861-4671

WASHINGTON

Seattle 98108
5419 Maynard Ave., So.
(206) 762-8430

WISCONSIN

(Milwaukee)
Brookfield 53005
4057 N. 128th St.
(414) 781-0951

TECH LIT:
ARCHIVE COPY



Band Saws

Catalog No.
6223

Two-Speed Bandsaw

Catalog No.
6224

Two-Speed Bandsaw
with Carrying Case

Catalog No.
6225

Two-Speed Bandsaw

Catalog No.
6226

Two-Speed Bandsaw
with Carrying Case

Catalog No.
6227

Variable Speed Bandsaw

Catalog No.
6234

Variable Speed Bandsaw
with Carrying Case

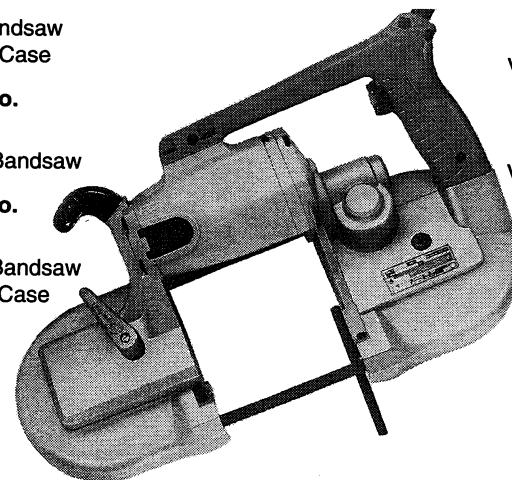
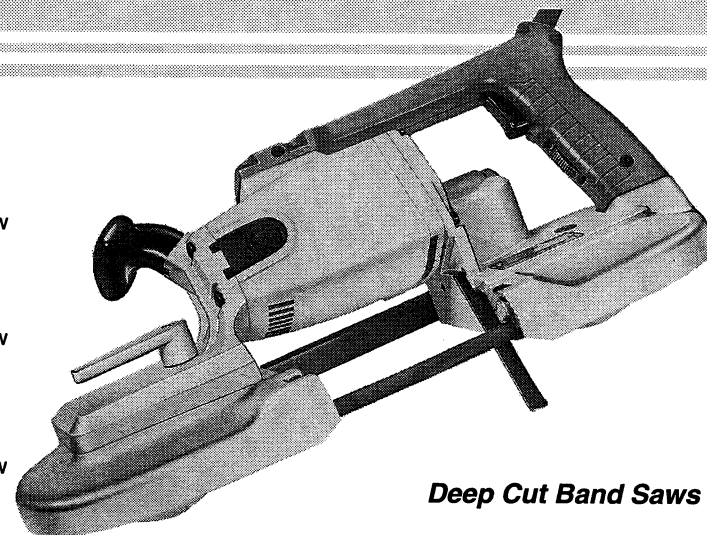

OPERATOR'S MANUAL

Deep Cut Band Saws

Catalog No.
6230

Variable Speed Bandsaw

Catalog No.
6232

Variable Speed Bandsaw
with Carrying Case

Catalog No.
6236

Two-Speed Bandsaw

Catalog No.
6238

Two-Speed Bandsaw
with Carrying Case

In addition, there is a nationwide network of distributors and authorized service stations ready to assist you. Check your "Yellow Pages" under "Tools-Electric" for the names of those nearest you.

WARRANTY

Every MILWAUKEE tool is thoroughly inspected and tested before leaving our manufacturing facilities. Should any trouble develop, return the complete tool prepaid to our Corporate Office, Branch Office/Service Center or nearest Authorized MILWAUKEE Service Station. If inspection shows the trouble is caused by defective workmanship or material, all repairs will be made without charge, and the tool will be returned, transportation prepaid. Battery packs for cordless tools are warranted for one year from the date of purchase.

This warranty does not apply where: (1) repairs or attempted repairs have been made by persons other than MILWAUKEE personnel or Authorized Service Station personnel; (2) repairs are required because of normal wear; (3) the tool has been abused or involved in an accident; (4) misuse is evident, such as caused by overloading the tool beyond its rated capacity; (5) the tool has been used after partial failure or (6) the tool has been used with an improper accessory. No other warranty, written or verbal, is authorized.

MILWAUKEE ELECTRIC TOOL CORPORATION

13135 West Lisbon Road • Brookfield, Wisconsin 53005

BEFORE USE, BE SURE EVERYONE USING THIS TOOL READS AND UNDERSTANDS THIS MANUAL.

Record the following information:

Catalog No. _____ Serial No. _____ Date Purchased _____

MILWAUKEE BAND SAWS

MILWAUKEE has served professionals exclusively, all day, every day since 1924. Red *MILWAUKEE* tools with the familiar lightning flash are used and recommended by thousands of plumbers, electricians, builders, carpenters, remodelers, welders, maintenance workers and others who need "heavy-duty" tools for professional work. *MILWAUKEE* has always recognized that professionals and professional work require a different power tool standard: a standard of EXCELLENCE IN QUALITY, PERFORMANCE, VALUE.

Standard Equipment:

Catalog No. 6223: Two-Speed Bandsaw

Catalog No. 6224: Two-Speed Bandsaw with Carrying Case

Catalog No. 6225: Two-Speed Bandsaw

Catalog No. 6226: Two-Speed Bandsaw with Carrying Case

Catalog No. 6227: Variable Speed Bandsaw

Catalog No. 6234: Variable Speed Bandsaw with Carrying Case

Catalog No. 6230: Variable Speed Bandsaw

Catalog No. 6232: Variable Speed Bandsaw with Carrying Case

Catalog No. 6236: Two-Speed Bandsaw

Catalog No. 6238: Two-Speed Bandsaw with Carrying Case

THIS SYMBOL . . .



. . . IS YOUR ASSURANCE

that every tool manufactured by *MILWAUKEE* is fully inspected and produced in accordance with applicable standards for safety established by OSHA, Underwriters Laboratories, Inc., the Canadian Standards Association and the American National Standards Institute (ANSI). *MILWAUKEE* Heavy-Duty Tools bearing the monograms of Underwriters Laboratories, Inc. or the Canadian Standards Association are listed by their testing laboratories as having complied with their standards for safety. Compliance is assured by continuing, independent inspections by both agencies.

Milwaukee Electric Tool Corporation assumes no responsibility for any damage or accidents resulting from the misuse of this tool, its misapplication or nonadherence to precautionary safety measures.

CONTENTS

Safety	3	Operation	8
Grounding	5	Maintenance	11
Extension Cords	6	Accessories	0
Specifications	6		
<i>MILWAUKEE</i> Bandsaws	7		

MAINTENANCE

WARNING!

To reduce the risk of injury, always unplug your tool before performing any maintenance. Never disassemble the tool or try to do any rewiring on the tool's electrical system. Contact a *MILWAUKEE* service facility for ALL repairs.

Maintaining Tools

Keep your tool in good repair by adopting a regular maintenance program. Before use, examine the general condition of your tool. Inspect guards, switches, tool cord set and extension cord for damage. Check for loose screws, misalignment, binding of moving parts, improper mounting, broken parts and any other condition that may affect its safe operation. If abnormal noise or vibration occurs, turn the tool off immediately and have the problem corrected before further use. Do not use a damaged tool. Tag damaged tools "DO NOT USE" until repaired (see "Repairs").

Under normal conditions, relubrication is not necessary until the motor brushes need to be replaced. After six months to one year, depending on use, return your tool to the nearest *MILWAUKEE* service facility for the following:

- Lubrication
- Brush inspection and replacement
- Mechanical inspection and cleaning (gears, spindles, bearings, housing, etc.)
- Electrical inspection (switch, cord, armature, etc.)
- Testing to assure proper mechanical and electrical operation

Cleaning

Clean dust and debris from vents. Keep the tool handles clean, dry and free of oil or grease. Use only mild soap and a damp cloth to clean your tool since certain cleaning agents and solvents are harmful to plastics and other insulated parts. Some of these include: gasoline, turpentine, lacquer thinner, paint thinner, chlorinated cleaning solvents, ammonia and household detergents containing ammonia. Never use flammable or combustible solvents around tools.

Repairs

If your tool is damaged, return the entire tool to the nearest:

Milwaukee Branch Office/Service Center,
Milwaukee Authorized
Portable Electric Tool Service Station
or
Milwaukee Electric Tool Corporation
13135 West Lisbon Road
Brookfield, WI 53005
(414) 781-3600

WARNING!

To reduce the risk of injury, electric shock and damage to the tool, never immerse your tool in liquid or allow a liquid to flow inside the tool.

**Starting, Stopping,
and Controlling Speed
for Cat. Nos. 6227, 6230, 6232, and 6234**

1. To start the tool, grasp the handle firmly and pull the trigger.
2. To vary the speed, simply increase or decrease pressure on the trigger. The further the trigger is pulled, the greater the speed.
3. To select a maximum preset speed at any point within the speed range, rotate the red knurled knob located on the trigger to the desired position.
4. To stop the tool, release the trigger. Allow the tool to come to a complete stop before removing the blade from a partial cut or laying the tool down.

Typical Application

1. Keep the blade off the workpiece until the motor has reached the selected speed.
2. Start cutting on a surface where the greatest number of teeth will be in contact with the workpiece at one time.
3. Place the work steady rest against the workpiece and lower the moving saw blade into the cut.
4. Do not bear down while cutting. The weight of the tool will supply adequate pressure for the fastest cutting.
5. When completing a cut, hold the tool firmly so it will not fall against the workpiece.

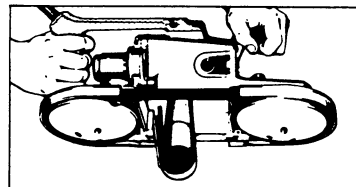
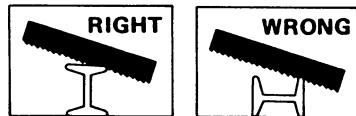

SAFETY

WARNING!

When using electric tools, always follow basic safety precautions to reduce the risk of fire, electric shock and personal injury.

READ AND SAVE ALL INSTRUCTIONS FOR FUTURE USE. Before use, be sure everyone using this tool reads and understands this manual as well as any labels packaged with or attached to the tool.

1. **KNOW YOUR POWER TOOL.** Read this manual carefully to learn your power tool's applications and limitations as well as potential hazards associated with this type of tool.
2. **GROUND YOUR TOOL** unless your tool is Double Insulated. See "Grounding."
3. **AVOID DANGEROUS ENVIRONMENTS.** Do not use your power tool in rain, damp or wet locations or in the presence of explosive atmospheres (gaseous fumes, dust or flammable materials). Remove materials or debris that may be ignited by sparks.
4. **KEEP WORK AREA CLEAN AND WELL LIT.** Cluttered, dark work areas invite accidents.
5. **DRESS PROPERLY.** Do not wear loose clothing or jewelry. Wear a protective hair covering to contain long hair. These may be caught in moving parts. When working outdoors, wear rubber gloves and insulated non-skid footwear. Keep hands and gloves away from moving parts.
6. **USE SAFETY EQUIPMENT.** Everyone in the work area should wear safety goggles or glasses with side shields complying with current safety standards. Wear hearing protection during extended use and a dust mask for dusty operations. Hard hats, face shields, safety shoes, etc. should be used when specified or necessary. Keep a fire extinguisher nearby.
7. **KEEP BYSTANDERS AWAY.** Children and bystanders should be kept at a safe distance from the work area to avoid distracting the operator and contacting the tool or extension cord.
8. **PROTECT OTHERS IN THE WORK AREA** from debris such as chips and sparks. Provide barriers or shields as needed.
9. **SECURE WORK.** Use a clamp, vise or other practical means to hold your work securely, freeing both hands to control the tool.
10. **USE THE RIGHT TOOL.** Do not use a tool or attachment to do a job for which it is not recommended. For example, do not use a circular saw to cut tree limbs or logs. Do not alter a tool.
11. **USE PROPER ACCESSORIES.** Using unrecommended accessories may be hazardous. Be sure accessories are properly installed and maintained. Do not defeat a guard or other safety device when installing an accessory or attachment.
12. **CHECK FOR DAMAGED PARTS.** Inspect guards and other parts before use. Check for misalignment, binding of moving parts, improper mounting, broken parts and any other conditions that may affect operation. If abnormal noise

or vibration occurs, turn the tool off immediately and have the problem corrected before further use. Do not use a damaged tool. Tag damaged tools "DO NOT USE" until repaired. A guard or other damaged part should be properly repaired or replaced by a MILWAUKEE service facility. For all repairs, insist on only identical replacement parts.

13. **REMOVE ALL ADJUSTING KEYS AND WRENCHES.** Make a habit of checking that adjusting keys, wrenches, etc. are removed from the tool before turning it on.
14. **GUARD AGAINST ELECTRIC SHOCK.** Prevent body contact with grounded surfaces such as pipes, radiators, ranges and refrigerators. **When making blind or plunge cuts, always check the work area for hidden wires or pipes.** Hold your tool by insulated nonmetal grasping surfaces. Use a Ground Fault Circuit Interrupter (GFCI) to reduce shock hazards.
15. **AVOID ACCIDENTAL STARTING.** Be sure your tool is turned off before plugging it in. Do not use a tool if the power switch does not turn the tool on and off. Do not carry a plugged-in tool with your finger on the switch.
16. **DO NOT FORCE TOOL.** Your tool will perform best at the rate for which it was designed. Excessive force only causes operator fatigue, increased wear and reduced control.
17. **KEEP HANDS AWAY FROM ALL CUTTING EDGES AND MOVING PARTS.**
18. **DO NOT ABUSE CORD.** Never carry your tool by its cord or unplug it by yanking the cord from the outlet. Pull plug rather than cord to reduce the risk of damage. Keep the cord away from heat, oil, sharp objects, cutting edges and moving parts.
19. **DO NOT OVERREACH. MAINTAIN**

CONTROL. Keep proper footing and balance at all times. Maintain a firm grip. Use extra care when using tool on ladders, roofs, scaffolds, etc.

20. **STAY ALERT.** Watch what you are doing, and use common sense. Do not use a tool when you are tired, distracted or under the influence of drugs, alcohol or any medication causing decreased control.
21. **UNPLUG TOOL** when it is not in use, before changing accessories or performing recommended maintenance.
22. **MAINTAIN TOOLS CAREFULLY.** Keep handles dry, clean and free from oil and grease. Keep cutting edges sharp and clean. Follow instructions for lubricating and changing accessories. Periodically inspect tool cords and extension cords for damage. Have damaged parts repaired or replaced by a *MILWAUKEE* service facility.
23. **STORE IDLE TOOLS.** When not in use, store your tool in a dry, secured place. Keep out of reach of children.
24. **MAINTAIN LABELS & NAME-PLATES.** These carry important information. If unreadable or missing, contact a *MILWAUKEE* service facility for a free replacement.

Changing Blades

1. **UNPLUG THE TOOL BEFORE REMOVING OR INSTALLING BLADES.**
2. Turn the tension lock handle located on the front of the saw 180-degrees counterclockwise. This releases the tension on the blade for easy removal.
3. Remove the blades from the pulley first and then from the guides.
4. To install a new blade, with the pulleys facing up, insert the blade between the rollers and the faces of the guides, making sure that the teeth on the left side of the tool point towards the rear of the tool.
5. With one hand, hold the blade in place between the rollers and the guides and use the other hand to position the blade around the pulleys. Be sure that the blade lies freely within the guard channel before starting the tool motor.
6. Turn the tension lock handle 180-degrees clockwise to lock the position. This will secure the blade on the pulleys.

BE SURE THAT THE BLADE IS PROPERLY SEATED ON THE PULLEYS BEFORE STARTING THE CUT.

Two Speed Switch for Cat. Nos. 6223, 6224, 6225, 6226, 6236, 6238

MILWAUKEE Two-Speed Band Saws are equipped with a speed change switch located below the trigger on the handle. To change speeds, stop the motor and slide the speed change switch to "HI" or "LO" as indicated on the tool. For cutting problem materials, use "LO" speed. Never change from one speed to the other while the motor is running.

OPERATION

WARNING!

To reduce the risk of injury, always unplug tool before attaching or removing accessories. Only use specifically recommended accessories. Others may be hazardous.

Blades and Blade Selection

Every **MILWAUKEE** Portable Bandsaw is furnished with a 14-teeth-per-inch Bi-metal blade which is suitable for most applications. The blade dimensions required for the band saws are: .020" thickness, 1/2" width and 44-7/8" in length. The special .020" thickness reduces flexure fatigue and provides maximum tooth life. To maximize cutting life, use a blade with the correct pitch (teeth per inch) for the specific cutting job.

Blades are available in several pitches. To select the proper blade, three factors should be considered: The size, shape, and type of material to be cut.

The following suggestions are for selecting the right blade for various cutting operations. Keep in mind that these are broad guidelines and that blade requirements may vary depending upon the specific size, shape and type of material to be cut. Generally, soft materials require coarse pitch blades and hard materials require fine pitch blades. Use coarse pitch blades for thick work and fine pitch blades for thin work. It is important to keep at least three teeth in the cut. See "Typical Application" on page 10.

6 TEETH/INCH

For tough stock 1/2" to 3-3/8" in diameter or width (available in carbon steel only)

8 TEETH/INCH

For tough stock 3/8" to 1" in diameter or width (available in carbon steel only)

10 TEETH/INCH

For tough stock 3/16" up to 4-3/4" in diameter or width

14 TEETH/INCH

For tough stock 5/32" to 3/4" in diameter or width

18 TEETH/INCH

For thin-wall tubing and thin sheets heavier than 21 gauge

24 TEETH/INCH

For thin-wall tubing and thin sheets heavier than 21 gauge

GROUNDING

Grounded Tools: Tools with Three Prong Plugs

Tools marked "Grounding Required" have a three wire cord and three prong grounding plug. The plug must be connected to a properly grounded outlet (see Figure A). If the tool should electrically malfunction or breakdown, grounding provides a low resistance path to carry electricity away from the user, reducing the risk of electric shock.

The grounding prong in the plug is connected through the green wire inside the cord to the grounding system in the tool. The green wire in the cord must be the only wire connected to the tool's grounding system and must never be attached to an electrically "live" terminal.

Your tool must be plugged into an appropriate outlet, properly installed and grounded in accordance with all codes and ordinances. The plug and outlet should look like those in Figure A.

Figure B illustrates a temporary adapter available for connecting grounded plugs (Figure A) to two prong outlets. The green rigid ear or lug extending from the adapter must be connected to a permanent ground such as a properly grounded outlet box or receptacle. Simply remove the center screw from the outlet, insert the adapter and reattach the screw through the green grounding ear to the outlet. If in doubt of proper grounding, call a qualified electrician. A temporary adapter should only be used until a properly grounded outlet can be installed by a qualified electrician. The Canadian Electrical Code prohibits the use of temporary adapters.

WARNING!

Improperly connecting the grounding wire can result in the risk of electric shock. Check with a qualified electrician if you are in doubt as to whether the outlet is properly grounded. Do not modify the plug provided with the tool. Never remove the grounding prong from the plug. Do not use the tool if the cord or plug is damaged. If damaged, have it repaired by a MILWAUKEE service facility before use. If the plug will not fit the outlet, have a proper outlet installed by a qualified electrician.

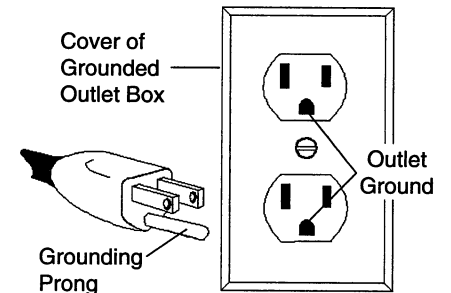

Fig. A

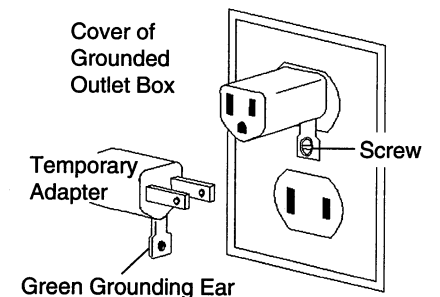

Fig. B

EXTENSION CORDS

Grounded tools require a three wire extension cord. Double insulated tools can use either a two or three wire extension cord. As the distance from the supply outlet increases, you must use a heavier gauge extension cord. Using extension cords with inadequately sized wire causes a serious drop in voltage, resulting in loss of power and possible tool damage. Refer to the table below to determine the required minimum wire size.

Recommended Minimum Wire Gauge for Extension Cords*

Nameplate Amperes	Extension Cord Length					
	25'	50'	75'	100'	150'	200'
0 - 5	16	16	16	14	12	12
5.1 - 8	16	16	14	12	10	--
8.1 - 12	14	14	12	10	--	--
12.1 - 15	12	12	10	10	--	--
15.1 - 20	10	10	10	--	--	--

*Based on limiting the line voltage drop to five volts at 150% of the rated amperes.

The smaller the gauge number of the wire, the greater the capacity of the cord. For example, a 14 gauge cord can carry a higher

current than a 16 gauge cord. When using more than one extension cord to make up the total length, be sure each cord contains at least the minimum wire size required. If you are using one extension cord for more than one tool, add the nameplate amperes and use the sum to determine the required minimum wire size.

Guidelines for Using Extension Cords

- If you are using an extension cord outdoors, be sure it is marked with the suffix "W-A" ("W" in Canada) to indicate that it is acceptable for outdoor use.
- Be sure your extension cord is properly wired and in good electrical condition. Always replace a damaged extension cord or have it repaired by a qualified person before using it.
- Protect your extension cords from sharp objects, excessive heat and damp or wet areas.

READ AND SAVE ALL INSTRUCTIONS FOR FUTURE REFERENCE.

SPECIFICATIONS

Catalog No.	No Load Surface ft. per min.	Volts	Capacity		Recommended Blades
			Round Stock	Rectangular Stock	
6223	200/250	120 AC/DC	3-1/2"	3-1/2" x 4-1/2"	All
6224	200/250	120 AC/DC	3-1/2"	3-1/2" x 4-1/2"	All
6225	200/250	120 AC	3-1/2"	3-1/2" x 4-1/2"	All
6226	200/250	120 AC	3-1/2"	3-1/2" x 4-1/2"	All
6227	0 - 250	120 AC	3-1/2"	3-1/2" x 4-1/2"	All
6234	0 - 250	120 AC	3-1/2"	3-1/2" x 4-1/2"	All
6230	0 - 350	120 AC	4-3/4"	4-3/4" x 4-3/4"	Bi-Metal
6232	0 - 350	120 AC	4-3/4"	4-3/4" x 4-3/4"	Bi-Metal
6236	250/350	120 AC/DC	4-3/4"	4-3/4" x 4-3/4"	Bi-Metal
6238	250/350	120 AC/DC	4-3/4"	4-3/4" x 4-3/4"	Bi-Metal

MILWAUKEE BANDSAWS

Band Saw

Cat Nos. 6223, 6224, 6225, 6226, 6227, and 6234

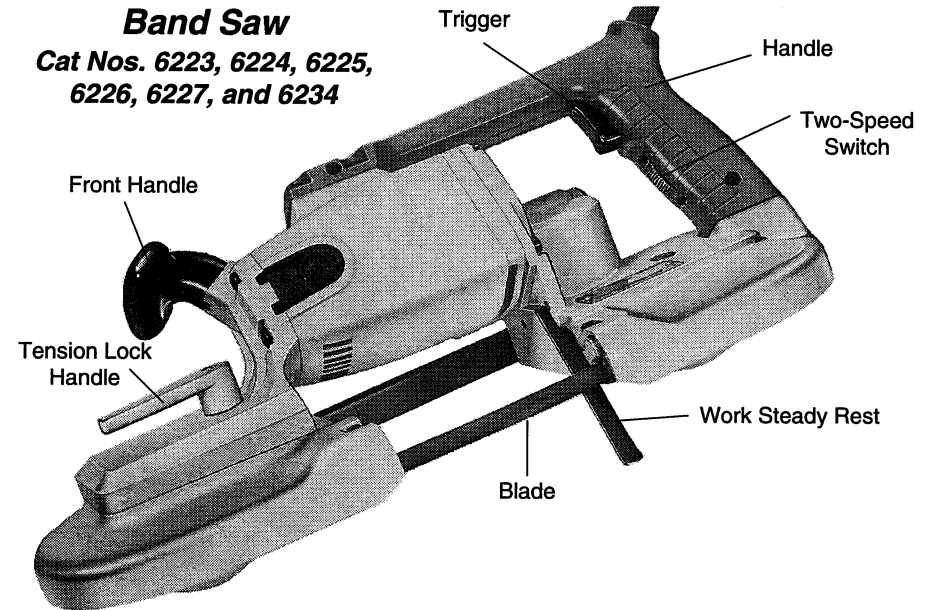

Deep Cut Band Saw

Cat Nos. 6230, 6232, 6236, and 6238

