



SERVICE PARTS LIST

BULLETIN NO.
54-40-7051

SPECIFY CATALOG NO. AND SERIAL NO. WHEN ORDERING PARTS		REVISED BULLETIN 54-40-7050	DATE Oct. 2017
CORDLESS METAL CUTTING SAW			
CATALOG NO. 0740-20	STARTING SERIAL NO. A94C	WIRING INSTRUCTION SEE REVERSE SIDE	

EXAMPLE:

00	0
----	---

 Component Parts (Small #) Are Included
 When Ordering The Assembly (Large #).

NOTE:
 Remove brush tubes (20) prior to removing armature assembly (15) from left handle half (38).
 Install brush tubes (20) into left handle half (38) only after armature assembly (15) has been secured into left handle half (38).

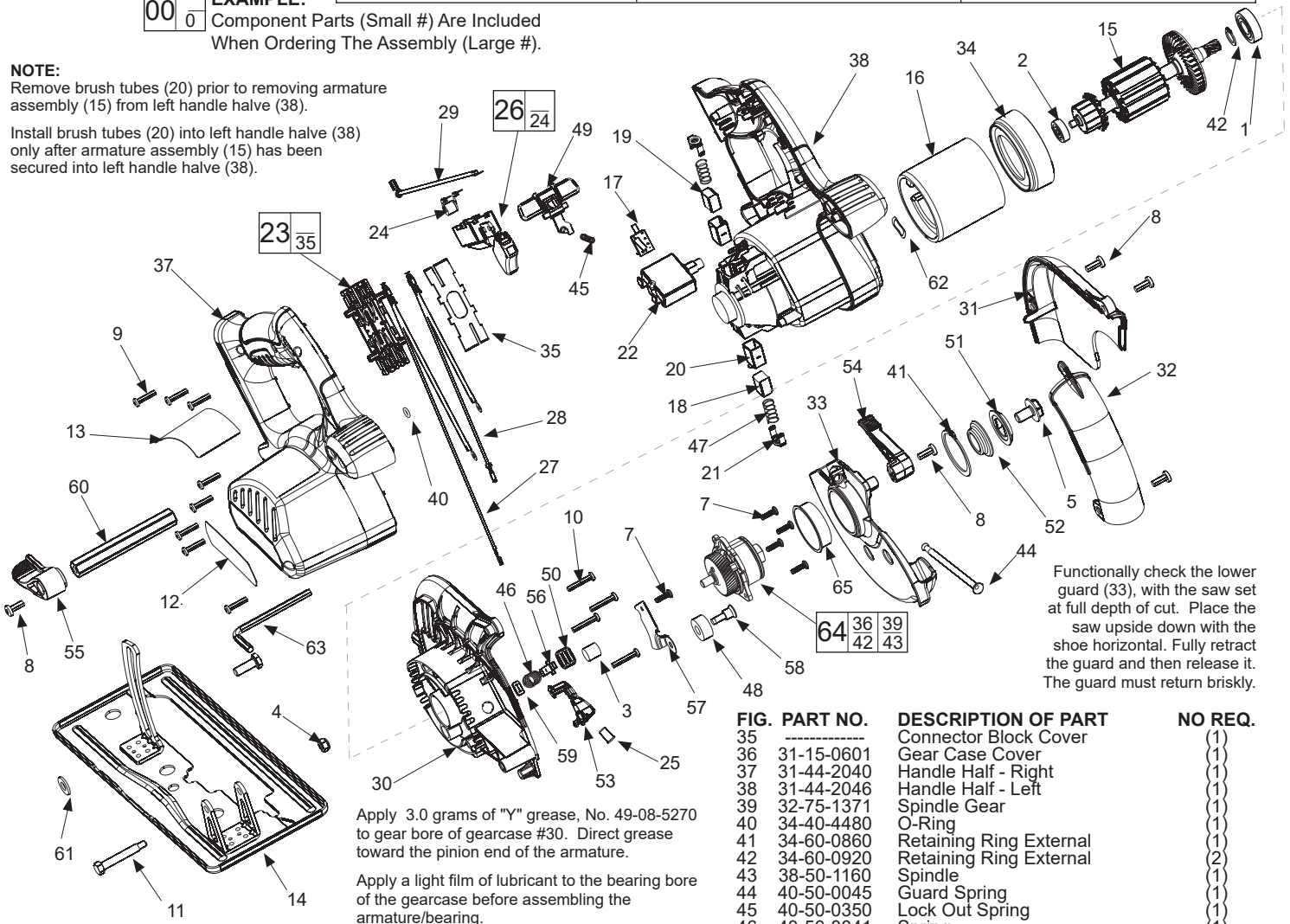

Functionally check the lower guard (33), with the saw set at full depth of cut. Place the saw upside down with the shoe horizontal. Fully retract the guard and then release it. The guard must return briskly.

Apply 3.0 grams of "Y" grease, No. 49-08-5270 to gear bore of gearcase #30. Direct grease toward the pinion end of the armature.
 Apply a light film of lubricant to the bearing bore of the gearcase before assembling the armature/bearing.

FIG. PART NO.	DESCRIPTION OF PART	NO REQ.
1	02-04-1212 Ball Bearing	(1)
2	02-04-5130 Ball Bearing	(1)
3	02-50-1640 Needle Bearing	(1)
4	06-57-1100 Lock Nut	(1)
5	06-75-1010 Left Hand Screw	(1)
6	06-75-5860 1/4-20 x 3/4 Screw	(1)
7	06-82-5285 6-32 X 1/2 TT TORX Pan	(5)
8	06-82-5314 10-24X1/2 Pan Tap TX SC	(8)
9	06-82-7470 Screw 6 X 11/16 Plastite	(4)
10	06-82-7475 Screw 6 X 7/8 Plastite	(1)
11	06-82-9685 Shoulder Bolt	(1)
12	10-20-2880 Logo Label	(1)
13	12-20-1250 Service Nameplate	(1)
14	14-74-0400 Shoe	(1)
15	16-01-0300 Armature	(1)
16	18-01-2000 Field	(1)
17	22-09-1075 Circuit Board	(1)
18	22-18-1245 Brush Assembly - Black	(1)
19	22-18-1250 Brush Assembly - Red	(1)
20	22-20-0425 Brush Tube	(2)
21	22-32-0420 Brush Spring Clip	(2)
22	22-36-0230 30 Amp Overload Protect	(1)
23	22-56-0975 Connector Block Assembly	(1)
24	22-74-0510 Diode	(1)
25	23-28-0175 LED	(1)
26	23-66-1005 Service Switch	(1)
27	23-94-2680 Lead Wire Assembly - Red	(1)
28	23-94-2690 Lead Wire Assembly - Black	(1)
29	23-94-2700 Lead Wire Breaker & Switch	(1)
30	28-14-0795 Gearcase	(1)
31	28-20-1174 Upper Guard Cover	(1)
32	28-41-0945 Upper Guard Window	(1)
33	28-41-1090 Lower Guard	(1)
34	31-05-0350 Baffle	(1)

FIG. PART NO.	DESCRIPTION OF PART	NO REQ.
35	Connector Block Cover	(1)
36	31-15-0601 Gear Case Cover	(1)
37	31-44-2040 Handle Half - Right	(1)
38	31-44-2046 Handle Half - Left	(1)
39	32-75-1371 Spindle Gear	(1)
40	34-40-4480 O-Ring	(1)
41	34-60-0860 Retaining Ring External	(1)
42	34-60-0920 Retaining Ring External	(2)
43	38-50-1160 Spindle	(1)
44	40-50-0045 Guard Spring	(1)
45	40-50-0350 Lock Out Spring	(1)
46	40-50-8041 Spring	(1)
47	40-50-8745 Brush Spring	(2)
48	42-38-0224 Bumper	(1)
49	42-42-1025 Switch Lock Out	(1)
50	42-42-1030 Spindle Lock Button	(1)
51	43-34-0795 Outer Blade Flange	(1)
52	43-34-0920 Inner Blade Flange	(1)
53	43-72-0600 LED Holder	(1)
54	44-10-0420 Guard Lever	(1)
55	44-10-0430 Depth Lever	(1)
56	44-20-0650 Spindle Lock	(1)
57	44-66-0845 Spindle Lock Plate	(1)
58	45-04-0485 Bumper Screw	(1)
59	45-06-0720 Felt Seal	(1)
60	45-08-0395 Depth Shaft	(1)
61	45-88-1515 Washer Flat 1/4	(1)
62	45-88-5615 Wave Spring Washer	(1)
63	49-96-0080 3/16" Hex Key	(1)
64	14-46-2570 Spindle and Gear Assembly	(1)
*65	45-14-0015 Sleeve Ring	(1)

FIG. NOTE:
 25, 30, 37 gearcase from right handle half.
 16, 38 Place field in left handle half with chamfered end in first. Line up slot in groove.
 15, 62 Install wave spring washer into left handle half bearing bore prior to installing armature assembly.
 23, 35 Assemble (snap fit) connector block cover with concave side facing connector block.

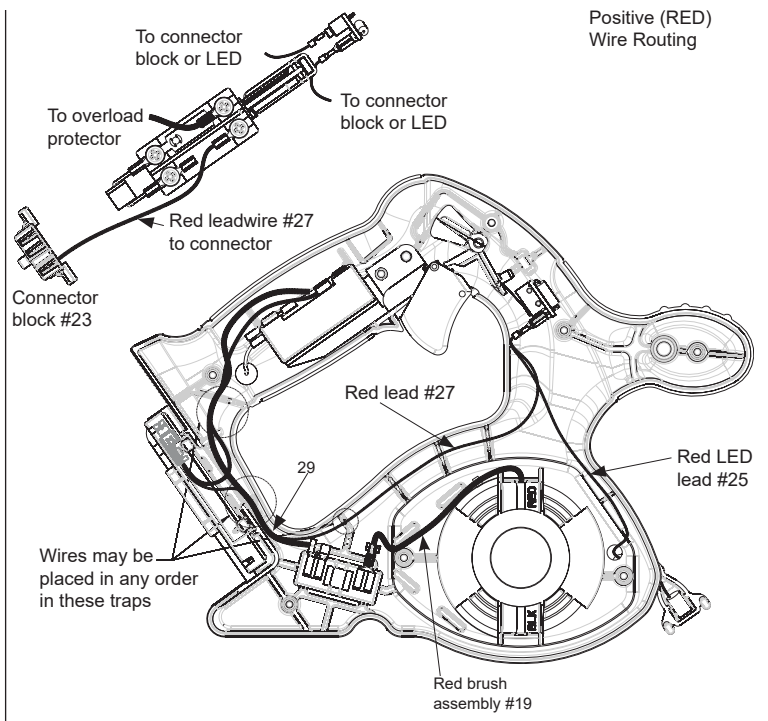
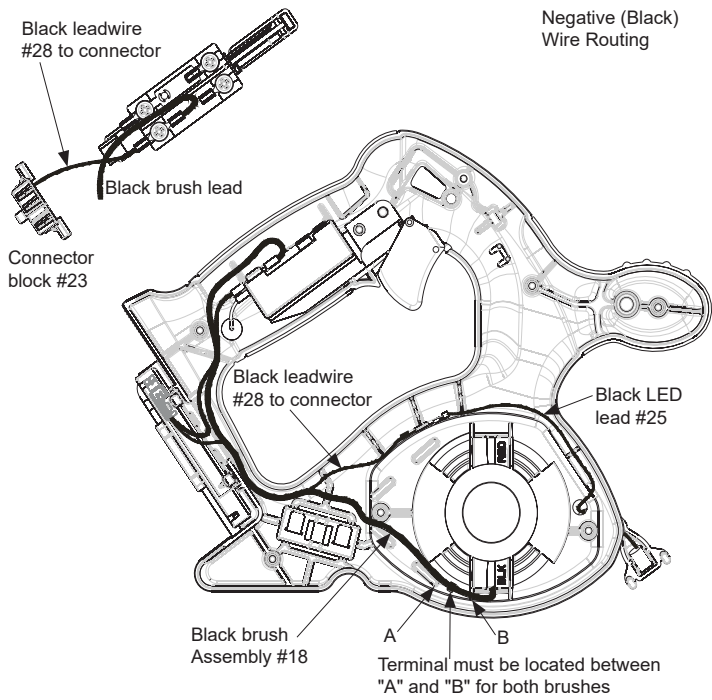

⚠ WARNING
SWITCH AND DIODE ARE POLARITY SENSITIVE
 If wired incorrectly, switch and diode **will be** damaged and destroyed!

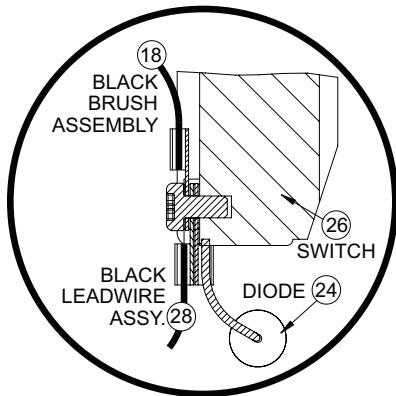

SWITCH DETAIL

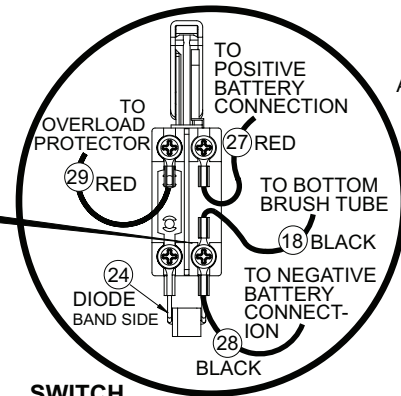

SWITCH BACK VIEW

ALL TERMINALS MUST BE ORIENTED AS SHOWN IN THESE VIEWS.

Functionally check switch lock-out #49 by attempting to turn on tool by applying a reasonable amount of force, up to 8 lbs., to the switch trigger #26. The tool must not turn on. Release trigger. Actuate the lock-out lever and apply a reasonable amount of force to the switch trigger. The tool and LED must turn on. While the trigger is still in the "ON" position, release the lock-out. Release the trigger. The tool and LED must stop and the lock-out lever must again prevent the actuation of the switch. Repeat the switch check two more times.

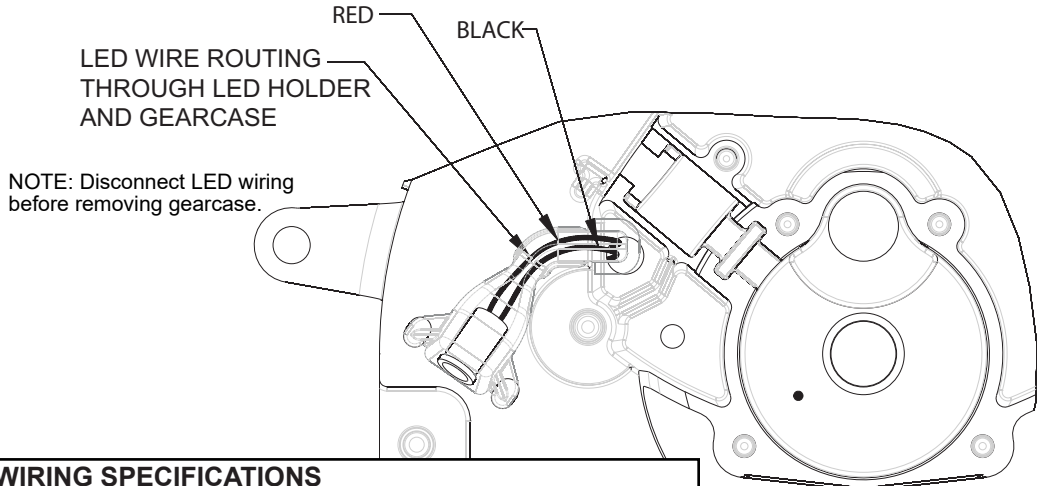

WIRING SPECIFICATIONS

Wire No.	Wire Color	Origin or Gauge	Length	Terminals, Connectors and 1 or 2 End Wire Preparation
19	Red	22-18-1250	----	Carbon brush assembly.
18	Black	22-18-1245	----	Carbon brush assembly.
27	Red	23-94-2680	----	Leadwire assembly.
28	Black	23-94-2690	----	Leadwire assembly.
		22-74-0510	----	Diode assembly.