

OPERATOR'S MANUAL

L90 MODEL CHAIN HOISTS

½TON THROUGH 10 TON

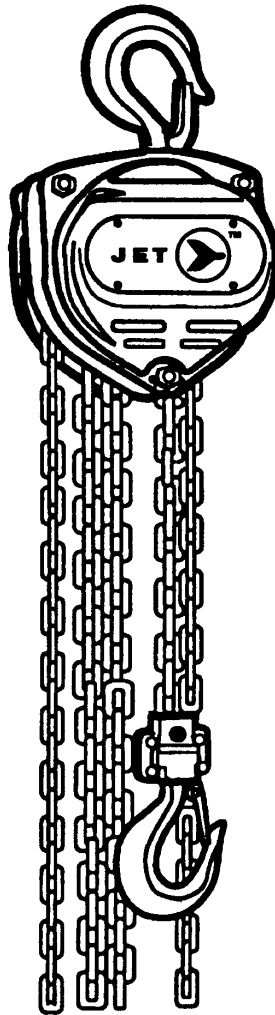

BRANCHES:

Vancouver
3260 Production Way
Burnaby, B.C.
V5A 4W4
Tel:(604) 444-5300
Toll free:1-800-472-7685
Fax:(604) 444-9227

Edmonton
4120 - 78 Avenue NW
Edmonton, Alberta
T6B 3M8
Toll free:
Tel: 1-800-468-1628
Fax: 1-800-663-7742

Winnipeg
951 Powell Avenue
Winnipeg, Manitoba
R3H 0H4
Tel:(204) 632-6970
Toll free:1-800-665-7524
Fax:(204) 694-9534

Toronto
416 Watline Avenue
Mississauga, Ontario
L4Z 1X2
Tel:(905) 502-8665
Toll free:1-800-387-3879
Fax:(905) 502-7707

Montreal
4620 rue Garand
St-Laurent, Quebec
H4R 2A2
Sans frais:
Tel:1-800-363-2885
Fax:1-800-267-3310

Halifax
#123-11 Morris Drive
Dartmouth, Nova Scotia
B3B 1M2
Tel:(902) 468-8324
Toll free:1-800-472-7686
Fax:(902) 468-3461

TABLE OF CONTENTS

WARRANTY POLICY	1
INFORMATION FOR YOUR SAFETY	1
PRIOR TO INSTALLATION	2
SAFETY PRECAUTIONS	2
INSPECTION AND MAINTENANCE	3
HOOKS	4
CHAIN	5
PARTS BREAKDOWN	6

ONE YEAR LIMITED WARRANTY

JET™ Manual Hoists are guaranteed to be free of defects in material and workmanship. If one of these products fails during the first year of operation due to defective material or workmanship it will be repaired or replaced at our discretion. Normal wear and tear on moving parts is excluded from this guarantee. This guarantee does not apply to any product showing signs of misuse, overloading, alteration, or improper maintenance.

WARRANTY PROCEDURE

After receiving authorization from one of the offices listed below, any product for which there is a warranty claim must be returned prepaid to an authorized JET™ warranty depot along with proof of purchase.

Addresses for information on JET™ Material Handling products, warranty depots or distributors:

Vancouver	Edmonton	Winnipeg	Toronto	Montreal	Halifax
3260 Production Way Burnaby, B.C. V5A 4W4 Tel: (604) 444-4336 Fax: (604) 444-9227	4120 - 78 Avenue NW Edmonton, Alberta T6B 3M8 Tel: (403) 468-1618 Fax: (403) 466-9879	1326 Border Street Winnipeg, Manitoba R3H 0M8 Tel: (204) 632-6970 Fax: (204) 694-9534	6830 Rexwood Road Mississauga, Ontario L4V 1L8 Tel: (905) 677-2103 Fax: (905) 677-8008	4620 Rue Garand St-Laurent, Quebec H4R 2A2 Tel: (514) 332-4612 Fax: (514) 332-4777	#123-11 Morris Drive Dartmouth, Nova Scotia B3B 1M2 Tel: (902) 468-8324 Fax: (902) 468-3461

INFORMATION FOR YOUR SAFETY

It is the responsibility of the owner/user to install, inspect, test, maintain, and operate these hand chain hoists in accordance with ASME B30.16, Safety Standard for Overhead Hoists.

These general instructions deal with the normal installation, operation and maintenance situations encountered with the hand chain hoists described herein. The instructions should not be interpreted to anticipate every possible contingency or to anticipate the final system or configuration that uses these hand chain hoists.

These instructions include information for a variety of hand chain hoists. Therefore, all instructions and information may not apply to one specific hand chain hoist. Disregard those portions of the instructions that do not apply.

If the hand chain hoist owner/user requires additional information, or if any information in these instructions is not clear, contact your local JET™ chain hoist distributor.

This hand chain hoist should not be installed, operated, or maintained by any person who has not read all the contents of these instructions, and ASME B30.16, Safety Standard for Overhead Hoists. Failure to read and comply with these instructions or any of the warnings or limitations noted herein can result in serious bodily injury or death, and/or property damage.

Only trained and qualified personnel shall operate and maintain this equipment.

Equipment described herein is not designed for, and should not be used for lifting, supporting, or transporting people.

User should not use this hand chain hoist in conjunction with other equipment unless necessary and/or required safety devices applicable to the system are installed by the user.

Modifications to upgrade, rerate or otherwise alter these hand chain hoists shall be authorized only by the original equipment manufacturer or qualified professional engineer.

PRIOR TO INSTALLATION

Check for damage during shipment. Place claim with carrier if any damage is discovered. DO NOT install or use a damaged hand chain hoist.

Check and verify that structure or other equipment that will support the hand chain hoist has a rated load capacity equal to or greater than the rated load capacity of the hand chain hoist to be used.

OPERATION

Before initial operation of hoist:

1. Read and comply with all instructions and warnings furnished with or attached to hoist.
2. Check lubricant.
3. Check operation of brake.
4. Check that chain is properly seated in sheaves and that chain is not twisted, kinked, or damaged.

Before each shift:

1. Inspect hooks for nicks, gouges, cracks, and signs of pulling apart or twisting.
2. Inspect hook latch for proper operation.
3. Check chain for kinks or twists.
4. Check operation of brake.
5. Replace warning label if missing or illegible.

Before operating:

1. Be certain all personnel are clear of the load to be lifted and moved.
2. Make sure load will clear stock piles, machinery, or other obstructions when hoisting and travelling the load.
3. Eliminate any twists or kinks in the load chain.

SAFETY PRECAUTIONS

- A. **READ** these instructions and ASME B30.16, Safety Standard for Overhead Hoists before installing, operating, or maintaining this equipment.
- B. **WARN** personnel of approaching loads.
- C. **DO NOT**
 1. Lift more than rated load.
 2. Operate hoist when it is restricted from forming a straight line with the direction of loading.
 3. Operate with twisted, kinked, or damaged chain.
 4. Operate if chain is not seated in sheaves or sprockets.
 5. Wrap chain around load or use chain as a sling.
 6. Operate unless load is properly applied to the saddle or bowl of the hook.
 7. Operate if load is applied to the tip of the hook.
 8. Operate with damaged or missing hook latches.
 9. Lift people or lift loads over people.
 10. Operate with side-pulling or side-loading of load to hoist.
 11. Operate a damaged or malfunctioning hoist.
 12. Operate with other than hand power.
 13. Remove, deface, or obscure warning label or labels on hoist.
 14. Leave load suspended when hoist is unattended unless specific precautions have been instituted and are in place.
 15. Lengthen load chain or repair damaged load chain by welding.
 16. Use chain as a ground for welding.

INSPECTION AND MAINTENANCE

Prior to initial use, all new, modified, and repaired hoists shall be inspected in accordance with Table 2. Thereafter, inspections shall be conducted at intervals shown in Table 1; and items to be inspected are indicated in Table 2 by F (Frequent) or P (Periodic).

Frequent Inspections - Visual inspection by the operator or other authorized person. This inspection includes listening for unusual sounds while the hoist is operated that may indicate deficiencies.

Periodic Inspections - Audible-visual inspection as for Frequent Inspections, with some disassembly to allow a more detailed inspection if external conditions indicate the need.

Exception: Brakes require more than audible-visual inspection. Check daily by operating hoist with and without load, stopping at various positions to test holding power and amount of drift, if any occurs. TO ADJUST BRAKE (Refer to Figure 1):

1. Fully tighten nut to position A.
2. Slack off nut from position A to position B and insert cotter key.

FIGURE 1

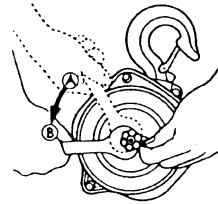

TABLE 1 - FREQUENCY OF INSPECTION

SERVICE	FREQUENT (F) INSPECTION	PERIODIC (P) INSPECTION
Normal	Monthly	Annually
Heavy	Weekly to Monthly	Semi-Annually
Severe	Daily to Weekly	Quarterly

TABLE 2 - INSPECTION CHART

In chart, F indicates Frequent Inspection, P indicates Periodic Inspection

LOCATION	CHECK FOR	F	P
Braking mechanism	Slipping under load	✓	
	Hard to release	✓	
Brake Parts			
	Brake Discs		✓
	Glazing		✓
	Oil contamination		✓
Pawl; Ratchet	Excessive wear		✓
Pawl Spring	Corrosion; stretch		✓
Hooks	Chemical damage	✓	
	Deformation	✓	
	5% in excess of normal throat opening		✓
	10° twist from plane of unbent hook		✓
	Cracks (dye penetrant, magnetic particle, or other suitable detection method)		✓

LOCATION	CHECK FOR	F	P
Hook Retaining Members (Pins, Bolts, Nuts)	Not tight or secure		✓
Hook Latch	Damaged; does not close	✓	
Suspension Members (Sheaves, hand-wheels, chain attachments, suspension bolts or pins)	Excessive wear		✓
	Cracks	✓	✓
Gears	Distortion		✓
	Broken or worn teeth		✓
	Cracks		✓
	Inadequate lubrication		✓
Load Block; Suspension Housing	Distortion	✓	✓
	Cracks	✓	✓
Trolley; Supporting Structure	Possible inability to continue supporting imposed loads		✓
Bolts, Nuts, Rivets	Not tight or secure		✓
WARNING Label	Removed or illegible	✓	

Refer to ASME B30.16 for additional information on inspection, test, and maintenance.

HOOKS

WARNING

1. Any hook that requires replacement because of excessive bends, twists, or throat opening indicates abuse or overloading of the hoist. Therefore, other load-supporting components of the hoist should be inspected for possible damage when such conditions are found.
2. Never repair hooks by welding or reshaping. Heat applied to the hook will alter the original heat treatment of the hook material and reduce the strength of the hook.
3. Never weld handles or other attachments to the hook. Heat applied to the hook will alter the original heat treatment of the hook material and reduce the strength of the hook.

HOOKS INSPECTION

Refers to ASME B30.10, Safety Standard for Hooks. Inspect hooks and measure hook throat opening at least once a month. Between regular inspections check visually daily for deformation, distortion, twisting, damage, and missing or damaged hook latches. Inspect as follows:

1. Measure hook throat opening from metal to metal of the hook as shown by dimension g in Figure 2. DO NOT measure from latch to metal. Hook must be replaced when throat opening measurement has increased 5% over the original throat opening dimension of a new hook, as follows:

CAPACITY TONS	DIMENSION g NEW HOOK	DIMENSION g REPLACE HOOK
1/2	30mm	31.5mm
1	34mm	35.7mm
1-1/2	39mm	40.9mm
2	43mm	45.2mm
3	50mm	52.5mm
5	58mm	60.9mm
10	70mm	73.5mm

FIGURE 2

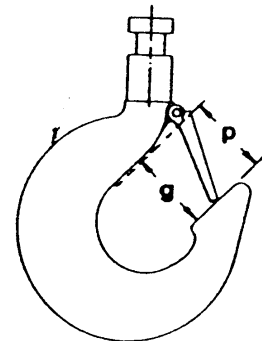

2. Measure hook depth at load bearing point (base, bowl or saddle) of the hook. Hook must be replaced when wear at load bearing point is 10% of the original depth of the hook load bearing point.
3. A bend or twist of the hook exceeding 10° from the plane of the unbent hook requires replacement of the hook.
4. A hook latch that is missing shall be replaced.
5. A hook latch that is inoperative shall be repaired or replaced.
6. A hook with a hook latch that does not close the throat opening of the hook shall be removed from service until the latch is replaced or repaired.
7. Hooks having damage from chemicals, corrosion, or deformation shall be repaired or replaced.

CHAIN

Inspect chain at least once a month. Between regular inspections, check visually daily for nicks, gouges, weld splatter, corrosion, or distorted links. Inspect chain thoroughly if it does not feed smoothly over load sheaves. Inspect as follows:

1. Clean chain with solvent before inspection.
2. Test hoist with load and observe operation of chain over load sheaves.
3. Slacken chain and inspect contact points for excessive wear. Refer to Figure 3.
4. Using caliper-type gauge, measure inside length of 5 links under light tension. Refer to Figure 4. Replace chain if measurement exceeds maximum allowable gauge length as follows:

CAPACITY TONS	CHAIN WIRE DIAMETER	5 LINKS NORMAL	5 LINKS MAXIMUM
1/2	5.0mm	75mm	77.6mm
1	6.3mm	95mm	98.3mm
2	8.0mm	120mm	124.1mm
1-1/2 and 3	7.1mm	105mm	108.6mm
5 and 10	9.0mm	135mm	139.6mm

FIGURE 3

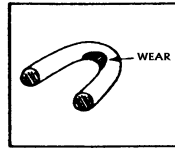
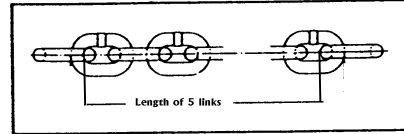

FIGURE 4



INSTALLING LOAD CHAIN

WARNING: DO NOT ADD TO LOAD CHAIN; REPLACE ENTIRE CHAIN

To install load chain into load chain sprocket:

1. Position load chain sprocket by rotating handchain wheel so that wide and narrow grooves show.
2. Using a forked poker, insert top chain link into sprocket grooves so that chain will wind up and back over sprocket. Welds must be away from sprocket.
3. Rotate handchain wheel so that load chain winds around sprocket. Stop when chain falls 6 to 8 inches at back of sprocket.
4. Attach end link of the load chain to the chain anchor.

To install load chain anchor when replacing old chain:

1. Remove cotter pin and chain anchor pin on chain anchor.
2. Insert bottom chain link into chain anchor.
3. Insert chain anchor pin through anchor brackets and chain link.
4. Insert cotter pin through hole in anchor pin and secure.

To install load chain into lower hook (1/2, 1, 1-1/2, and 2 ton):

1. Remove cotter pin from castle nut and remove nut.
2. Insert last chain link into lower hook slot. Check that chain is not twisted.
3. Insert chain bolt into lower hook slot.
4. Insert chain bolt through lower hook slot and chain link.
5. Secure castle nut to end of bolt.
6. Insert cotter pin into castle nut and secure.

To install load chain into lower hook (3, 5, and 10 ton):

1. After installing load chain into load chain sprocket, run remaining chain through hands, removing any twist. Last link of chain must be in same direction as first. If not, cut off last link.
2. Insert last link into left-hand pulley of lower hook. Pull chain through and up from underside of pulley.
3. Check that chain stopper is on right-hand side.
4. Insert last link into right-hand pulley of upper hook, moving chain up, back, then down. Check that chain is not twisted and welds face away from pulley.
5. Insert last link into right-hand pulley of lower hook, pulling up from underside of pulley. Check that chain is not twisted.
6. Insert last link over left-hand pulley of upper hook, moving chain up, back, then down.
7. To prevent free-wheeling of chain, insert screwdriver securely into link at base of upper pulley.
8. Remove cotter pin, castle nut, and chain bolt in lower hook slot.
9. Insert last link into slot.
10. Check that chain is not twisted.
11. Position bolt back through lower hook slot and last chain link.
12. Place castle nut onto end of bolt.
13. Secure cotter pin in tapered hole of bolt.
14. Remove screwdriver from link at base of upper pulley.

Install load chain for 3 ton and 5 ton hoists in same manner as above but allow for fewer falls of chain.

L-90 PARTS

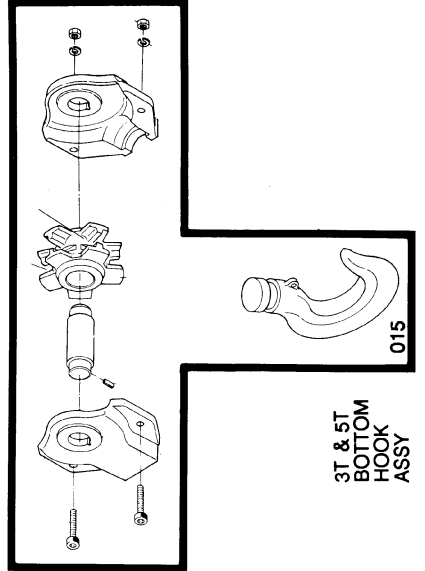
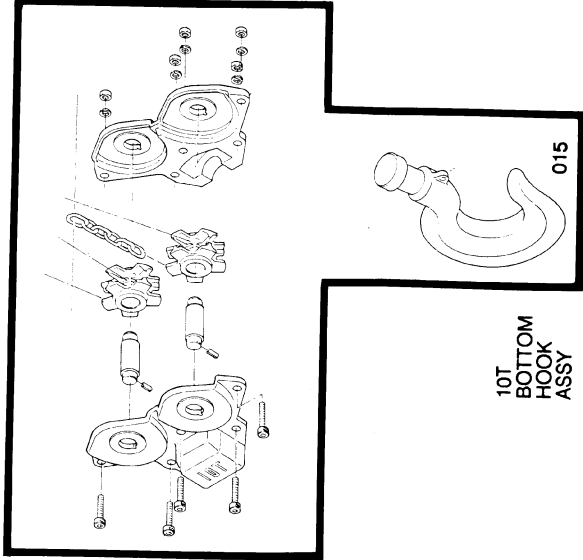
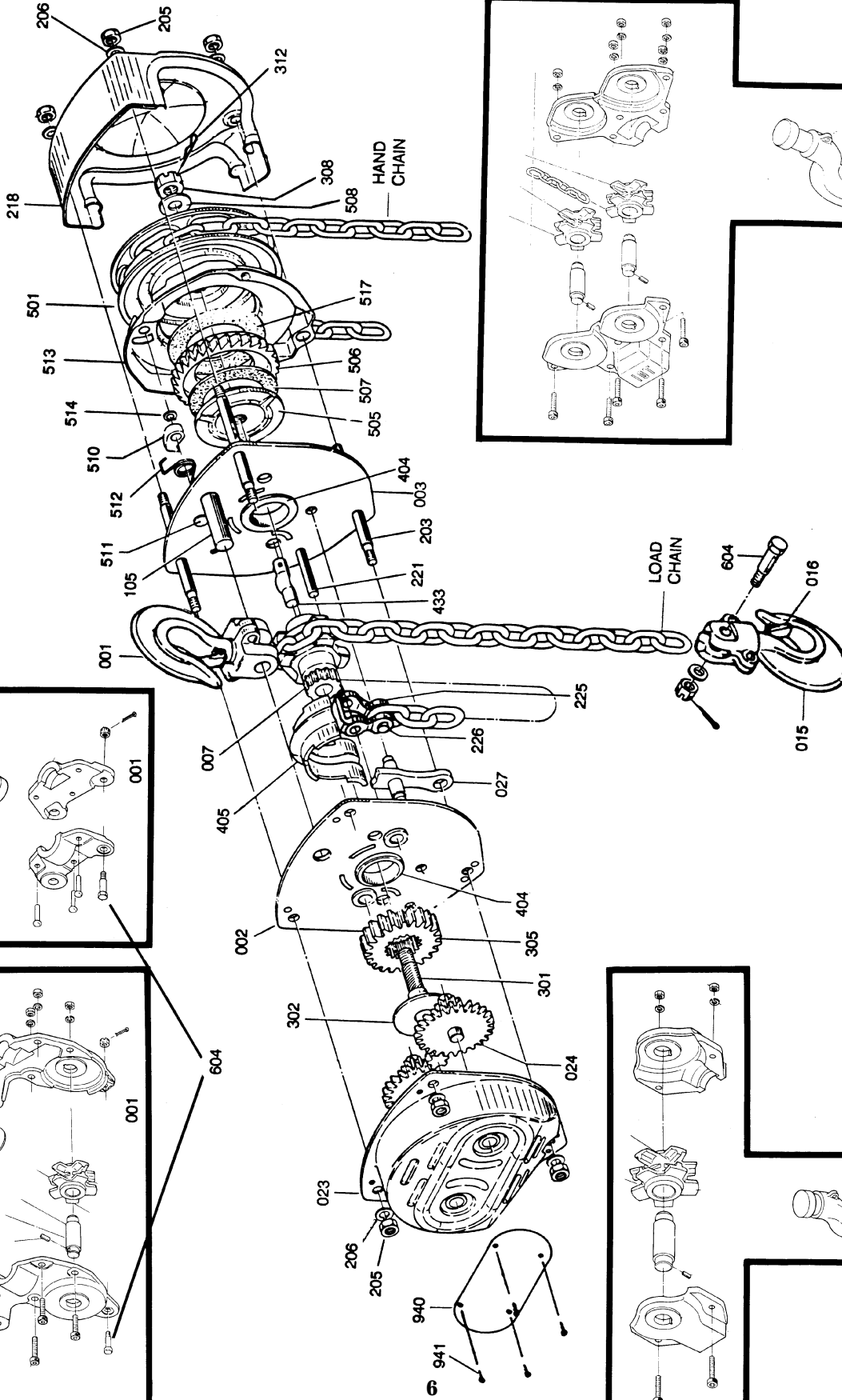
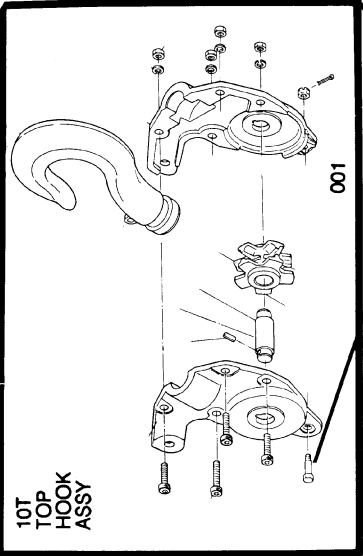
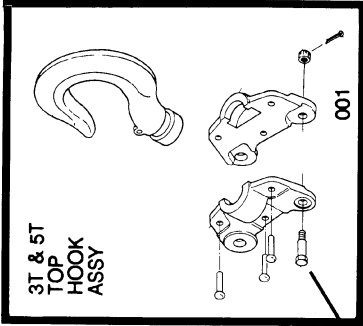
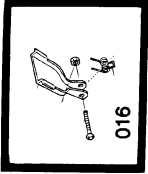

L-90 1/2 TON - 5 TON MODEL

ITEM#	DESCRIPTION
001	TOP HOOK ASSY
002	GEAR SIDE PLATE ASSY
003	WHEEL SIDE PLATE ASSY
007	LOAD SHEAVE ASSY
015	BOTTOM HOOK ASSY
016	SAFETY LATCH ASSY (OLD STYLE)
	SAFETY LATCH ASSY (NEW
023	STYLE)
024	GEAR CASE ASSY
027	2ND & 3RD GEAR ASSY
105	STRIPPER ASSY
203	TOP HOOK PIN
205	STAY BOLT
206	COVER NUT
218	WASHER
221	HAND WHEEL COVER
225	CHAIN STOP PIN
226	ANCHOR PLATE
301	ANCHOR PLATE PIN
302	DRIVING SHAFT
305	DRIVING SHAFT WASHER
308	LOAD GEAR
312	CASTLE NUT
404	CASTLE NUT PIN
405	LOAD METAL
433	LOAD SHEAVE COVER
501	LOAD SHEAVE COVER PIN
505	HAND CHAIN WHEEL
506	DISC HUB
507	RATCHET GEAR
508	FRICTION DISC
510	CHECK WASHER
511	PAWL
512	PAWL PIN
513	PAWL SPRING
517	BRAKE COVER
604	FRICTION DISC
940	CHAIN STOP BOLT ASSY
941	NAME PLATE
	RIVET

BE SURE TO STATE TONNAGE WHEN ORDERING PARTS

L-90 10 TON MODEL

ITEM#	DESCRIPTION
001	TOP HOOK ASSY
002	GEAR SIDE PLATE ASSY
003	WHEEL SIDE PLATE ASSY
007	LOAD SHEAVE ASSY
015	BOTTOM HOOK ASSY
016	SAFETY LATCH ASSY
023	GEAR CASE ASSY
024	2ND & 3RD GEAR ASSY
027	STRIPPER ASSY
105	TOP HOOK PIN
203	STAY BOLT
205	COVER NUT
206	WASHER
218	HAND WHEEL COVER
221	CHAIN STOP PIN
225	ANCHOR PLATE
226	ANCHOR PLATE PIN
301	DRIVING SHAFT
302	DRIVING SHAFT WASHER
305	LOAD GEAR
308	CASTLE NUT
312	CASTLE NUT PIN
404	LOAD METAL
405	LOAD SHEAVE COVER
433	LOAD SHEAVE COVER PIN
501	HAND CHAIN WHEEL
505	DISC HUB
506	RATCHET GEAR
507	FRICION DISC
508	CHECK WASHER
510	PAWL
511	PAWL PIN
512	PAWL SPRING
513	BRAKE COVER
517	FRICION DISC
604	CHAIN STOP BOLT ASSY
940	NAME PLATE
941	RIVET