



# Operating Instructions and Parts Manual

## Arbor Press – ½-, 1-, 2-, 3-, 5-Ton

Model No. AP0-M, AP1-M, AP2-M, AP3-M, AP5-M



**JET**  
427 New Sanford Road  
LaVergne, Tennessee 37086  
Ph.: 800-274-6848  
[www.jettools.com](http://www.jettools.com)

**Part No. M-333605M**  
Revision B 12/2015  
Copyright © 2015 JET

# Warranty and Service

JET warrants every product it sells against manufacturers' defects. If one of our tools needs service or repair, please contact Technical Service by calling 1-800-274-6846, 8AM to 5PM CST, Monday through Friday.

## Warranty Period

The general warranty lasts for the time period specified in the literature included with your product or on the official JET branded website.

- JET products carry a limited warranty which varies in duration based upon the product. (See chart below)
- Accessories carry a limited warranty of one year from the date of receipt.
- Consumable items are defined as expendable parts or accessories expected to become inoperable within a reasonable amount of use and are covered by a 90 day limited warranty against manufacturer's defects.

## Who is Covered

This warranty covers only the initial purchaser of the product from the date of delivery.

## What is Covered

This warranty covers any defects in workmanship or materials subject to the limitations stated below. This warranty does not cover failures due directly or indirectly to misuse, abuse, negligence or accidents, normal wear-and-tear, improper repair, alterations or lack of maintenance. JET woodworking machinery is designed to be used with Wood. Use of these machines in the processing of metal, plastics, or other materials outside recommended guidelines may void the warranty. The exceptions are acrylics and other natural items that are made specifically for wood turning.

## Warranty Limitations

Woodworking products with a Five Year Warranty that are used for commercial or industrial purposes default to a Two Year Warranty. Please contact Technical Service at 1-800-274-6846 for further clarification.

## How to Get Technical Support

Please contact Technical Service by calling 1-800-274-6846. **Please note that you will be asked to provide proof of initial purchase when calling.** If a product requires further inspection, the Technical Service representative will explain and assist with any additional action needed. JET has Authorized Service Centers located throughout the United States. For the name of an Authorized Service Center in your area call 1-800-274-6846 or use the Service Center Locator on the JET website.

## More Information

JET is constantly adding new products. For complete, up-to-date product information, check with your local distributor or visit the JET website.

## How State Law Applies

This warranty gives you specific legal rights, subject to applicable state law.

## Limitations on This Warranty

JET LIMITS ALL IMPLIED WARRANTIES TO THE PERIOD OF THE LIMITED WARRANTY FOR EACH PRODUCT. EXCEPT AS STATED HEREIN, ANY IMPLIED WARRANTIES OF MERCHANTABILITY AND FITNESS FOR A PARTICULAR PURPOSE ARE EXCLUDED. SOME STATES DO NOT ALLOW LIMITATIONS ON HOW LONG AN IMPLIED WARRANTY LASTS, SO THE ABOVE LIMITATION MAY NOT APPLY TO YOU. JET SHALL IN NO EVENT BE LIABLE FOR DEATH, INJURIES TO PERSONS OR PROPERTY, OR FOR INCIDENTAL, CONTINGENT, SPECIAL, OR CONSEQUENTIAL DAMAGES ARISING FROM THE USE OF OUR PRODUCTS. SOME STATES DO NOT ALLOW THE EXCLUSION OR LIMITATION OF INCIDENTAL OR CONSEQUENTIAL DAMAGES, SO THE ABOVE LIMITATION OR EXCLUSION MAY NOT APPLY TO YOU.

JET sells through distributors only. The specifications listed in JET printed materials and on official JET website are given as general information and are not binding. JET reserves the right to effect at any time, without prior notice, those alterations to parts, fittings, and accessory equipment which they may deem necessary for any reason whatsoever. JET® branded products are not sold in Canada by JPW Industries, Inc.

## Product Listing with Warranty Period

90 Days – Parts; Consumable items
1 Year – Motors; Machine Accessories
2 Year – Metalworking Machinery; Electric Hoists, Electric Hoist Accessories; Woodworking Machinery used for industrial or commercial purposes
5 Year – Woodworking Machinery
Limited Lifetime – JET Parallel clamps; VOLT Series Electric Hoists; Manual Hoists; Manual Hoist Accessories; Shop Tools; Warehouse & Dock products; Hand Tools; Air Tools

NOTE: JET is a division of JPW Industries, Inc. References in this document to JET also apply to JPW Industries, Inc., or any of its successors in interest to the JET brand.

# Table of Contents

Warranty and Service .....	2
Table of Contents .....	3
Warnings .....	4
Introduction.....	5
Specifications .....	5
Arbor Press Features .....	6
Set-up and Operation.....	6
Changing Ram Position .....	6
Maintenance.....	6
Parts Lists.....	7
Exploded View.....	8

The specifications in this manual are given as general information and are not binding. JET reserves the right to effect, at any time and without prior notice, changes or alterations to parts, fittings, and accessory equipment deemed necessary for any reason whatsoever.



# Warnings

1. Read and understand the entire owner's manual before attempting assembly or operation.
2. Read and understand the warnings posted on the machine and in this manual. Failure to comply with all of these warnings may cause serious injury.
3. Replace the warning labels if they become obscured or removed.
4. This arbor press is designed and intended for use by properly trained and experienced personnel only. If you are not familiar with the proper and safe operation of an arbor press, do not use until proper training and knowledge have been obtained.
5. Do not use this arbor press for other than its intended use. If used for other purposes, JET disclaims any real or implied warranty and holds itself harmless from any injury that may result from that use.
6. Always wear approved safety glasses/face shields while using this arbor press. Everyday eyeglasses only have impact resistant lenses; they are not safety glasses.
7. Do not operate this arbor press while tired or under the influence of drugs, alcohol or any medication.
8. Make sure this arbor press is firmly secured to the floor or bench before use.
9. Check damaged parts. Before further use of the arbor press, a part that is damaged should be carefully checked to determine that it will operate properly and perform its intended function. Check for alignment of moving parts, binding of moving parts, breakage of parts, mounting and any other conditions that may affect its operation. A guard or other part that is damaged should be properly repaired or replaced.
10. Provide for adequate space surrounding work area and non-glare, overhead lighting.
11. Keep the floor around the arbor press clean and free of scrap material, oil and grease.
12. Keep visitors a safe distance from the work area. **Keep children away.**
13. Make your workshop child proof with padlocks, master switches or by removing starter keys.
14. Give your work undivided attention. Looking around, carrying on a conversation and "horse-play" are careless acts that can result in serious injury.
15. Maintain a balanced stance at all times so that you do not fall into the arbor press. Do not overreach or use excessive force to perform any machine operation.
16. Use recommended accessories; improper accessories may be hazardous.
17. Make sure the work piece is securely attached or clamped to the table.
18. Remove loose items and unnecessary work pieces from the area before starting the machine.
19. Do not overload the arbor press by using extension (cheater) bars.
20. Use steel collars to support parts when pressing on bearings to prevent damage to the bearings.

## Familiarize yourself with the following safety notices used in this manual:



This means that if precautions are not heeded, it may result in minor injury and/or possible machine damage.



This means that if precautions are not heeded, it may result in serious, or even fatal, injury.

## Introduction

The arbor press is designed for riveting, swaging, bending, punching, and flattening. The arbor press can be used to press on or remove close-fitting bearings and bushings. It is suited for the production environment as well as machine shops, automobile repair shops, and home workshops.

The anvil has four slots that are available for a variety of pressing operations.

## Specifications

Stock#	333605	333610	333620	333630	333650
Model#	AP0-M	AP1-M	AP2-M	AP3-M	AP5-M
Pressure (ton)	1/2 Ton	1 Ton	2 Ton	3 Ton	5Ton
Capacity over Table (in.)	4-3/4	5	7-1/2	11-1/2	17
Diameter of Work (in.)	6-5/8	8	10-3/4	11-3/8	17
Anvil Diameter (in.)	3-1/2	3-1/2	6-11/16	6-11/16	9-3/4
Size of Ram (in.)	3/4 x 7-7/8	1 x 9-1/8	1-1/4 x 13	1-1/2 x 18	2 x 27-1/2
Ram Bore (in.)	3/8	1/2	1/2	1/2	1/2
Ram Travel (in.)	4.72	5.9	9.05	12.6	18.1
Base Size (in.)	4 x 9-1/2	5 x 9-1/2	6-3/8 x 15-3/4	8-1/2 x 18	9-7/8 x 26
Overall Dimensions:					
Length (in.)	9-5/16	9-1/2	15-3/4	18-1/8	27
Width (in.)	6-5/8	7-1/2	10	10-1/4	13
Height (in.)	10-3/8	12	17-1/2	22-1/2	31-1/2
Net Weight (lb.)	17-1/2	25-1/2	67-1/2	108	262
Shipping Weight (lb.)	19	26-1/2	69-1/2	116	296-1/2

The above specifications were current at the time this manual was published, but because of our policy of continuous improvement, JET reserves the right to change specifications at any time and without prior notice, without incurring obligations.

**⚠ WARNING** Read and understand the entire contents of this manual before attempting assembly or operation! Failure to comply may cause serious injury!

## Arbor Press Features

The arbor press (see Exploded view on page 8) consists of a cast iron base, an anvil, a pressing handle with lock knob, and a rack-type ram.

The removable anvil has four cutouts that can be used for pressing off or pressing on bearings or bushings of various sizes.

## Set-up and Operation

**Note:** Numbers in parentheses below correspond to item numbers in the exploded view on page 8.

**⚠WARNING** Do not use the arbor press without first securing the arbor press to the workbench and anchoring the workbench to the floor.

Mount the arbor press to the workbench or stand and secure with bolts using the holes in the base (1). Also, secure the workbench or stand to the floor.

## Changing Ram Position

The ram has a flat surface on one end and a hole on the other end. The hole is used to accept the punch inserts. Change-out the ram as follows:

- A. Remove the handle by loosening the knob (17). Then remove one cap (5) from the handle assembly. Remove handle (6) from the pinion (16).
- B. Remove the pinion retainer (14) by backing off the Set Screw (13). Now slide the pinion retainer (14) off of the pinion (16).
- C. Pull up on the ram (4) enough to provide slack to remove the pinion (16) from the arbor press.
- D. Pull the ram (4) out the top of the arbor press body. Turn the ram (4) end-for-end.

Tip: If ram does not freely come out of arbor press body, loosen the two hex nuts (11) on side of arbor press body and the two hex nuts (11) on the front plate (12).

- E. Repeat steps A – D in reverse.

## Maintenance

- A. Periodically lubricate the arbor press with a light machine oil.
- B. Wipe off or vacuum the accumulated debris and dust after using the arbor press.
- C. Periodically check the ram for side-to-side and front-to-back play. If the play is excessive, loosen the hex nuts (11) and adjust (tighten) the screws (10 on side, 9 in front) just enough to eliminate the excess play. Tighten them equally to assure even contact with the ram (4).
- D. Once the play is eliminated, hold the screw (10 or 9) in position and tighten the hex nut (11). Check to make sure the amount of play is acceptable.

# Parts Lists

## Model AP0-M – 1/2-ton Arbor Press

Index	Part No.	Description	Qty
1	AP0-01G	Base	1
2	AP0-06G	Anvil	1
3	AP0-16	Spring Pin 6x16	1
4	AP0-02	Ram	1
5	AP0-5-1	Cap	2
6	AP0-6-1	Handle	1
7	TS-1482051	Bolt, Hex M6x25	4
8	TS-1550041	Washer M6	4
9	TS-1482051	Bolt, Hex M6x25	2
10	TS-1482061	Bolt, Hex M6x30	2
11	TS-1540041	Nut, Hex M6	4
12	AP0-12G	Plate	1
13	TS-1523011	SHSS M6x6	1
14	AP0-10	Pinion Retainer	1
15	TS-1482021	Bolt, Hex M6x12	1
16	AP0-03	Pinion	1
17	AP0-05	Knob	1
18	TS-2361061	Lock Washer M6	4
	AP0-19	ID Label (not shown)	1

## Model AP1-M – 1-ton Arbor Press

Index	Part No.	Description	Qty
1	AP1-01G	Base	1
2	AP1-06G	Anvil	1
3	AP0-16	Spring Pin 6x16	1
4	AP1-02	Ram	1
5	AP1-5-1	Cap	2
6	AP1-6-1	Handle	1
7	TS-1482051	Bolt, Hex M6x25	4
8	TS-1550041	Washer M6	4
9	TS-1482051	Bolt, Hex M6x25	2
10	TS-1482061	Bolt, Hex M6x30	2
11	TS-1540041	Nut, Hex M6	4
12	AP1-12G	Plate	1
13	TS-1523011	SHSS M6x6	1
14	AP1-10	Pinion Retainer	1
15	TS-1482021	Bolt, Hex M6x12	1
16	AP1-03	Pinion	1
17	AP1-05	Knob	1
18	TS-2361061	Lock Washer M6	4
	AP1-19	ID Label (not shown)	1

## Model AP2-M – 2-ton Arbor Press

Index	Part No.	Description	Qty
1	AP2-01G	Base	1
2	AP2-06G	Anvil	1
3	AP2-16	Spring Pin 6x25	1
4	AP2-02	Ram	1
5	AP2-5-1	Cap	2
6	AP2-6-1	Handle	1
7	TS-1490051	Bolt, Hex M8x30	4
8	TS-1550061	Washer M8	4

9	TS-1490051	Bolt, Hex M8x30	2
10	TS-1490051	Bolt, Hex M8x30	2
11	TS-1540061	Nut, Hex M8	4
12	AP2-12G	Plate	1
13	TS-1523011	SHSS M6x6	1
14	AP2-10	Pinion Retainer	1
15	TS-1490021	Bolt, Hex M8x16	1
16	AP2-03	Pinion	1
17	AP2-05	Knob	1
18	TS-2361081	Lock Washer M8	4
	AP2-19	ID Label (not shown)	1

## Model AP3-M – 3-ton Arbor Press

Index	Part No.	Description	Qty
1	AP3-01G	Base	1
2	AP3-06G	Anvil	1
3	AP2-16	Spring Pin 6x25	1
4	AP3-02	Ram	1
5	AP3-5-1	Cap	2
6	AP3-6-1	Handle	1
7	TS-1490051	Bolt, Hex M8x30	4
8	TS-1550061	Washer M8	4
9	TS-1490051	Bolt, Hex M8x30	2
10	TS-1490051	Bolt, Hex M8x30	2
11	TS-1540061	Nut, Hex M8	4
12	AP3-12G	Plate	1
13	TS-1524011	SHSS M8x8	1
14	AP3-10	Pinion Retainer	1
15	TS-1490031	Bolt, Hex M8x20	1
16	AP3-03	Pinion	1
17	AP3-05	Knob	1
18	TS-2361081	Lock Washer M8	4
	AP3-19	ID Label (not shown)	1

## Model AP5-M – 5-ton Arbor Press

Index	Part No.	Description	Qty
1	AP5-01G	Base	1
2	AP5-06G	Anvil	1
3	AP5-16	Spring Pin 6x24	1
4	AP5-02	Ram	1
5	AP5-5-1	Cap	2
6	AP5-6-1	Handle	1
7	TS-1491061	Bolt, Hex M10x40	4
8	TS-1550071	Washer M10	4
9	TS-1491061	Bolt, Hex M10x40	2
10	TS-2210501	Bolt, Hex M10x50	2
11	TS-1540071	Nut, Hex M10	4
12	AP5-12G	Plate	1
13	TS-1524031	SHSS M8x12	1
14	AP5-10	Pinion Retainer	1
16	AP5-03	Pinion	1
18	TS-2361101	Lock Washer M10	4
	AP5-19	ID Label (not shown)	1

# Exploded View

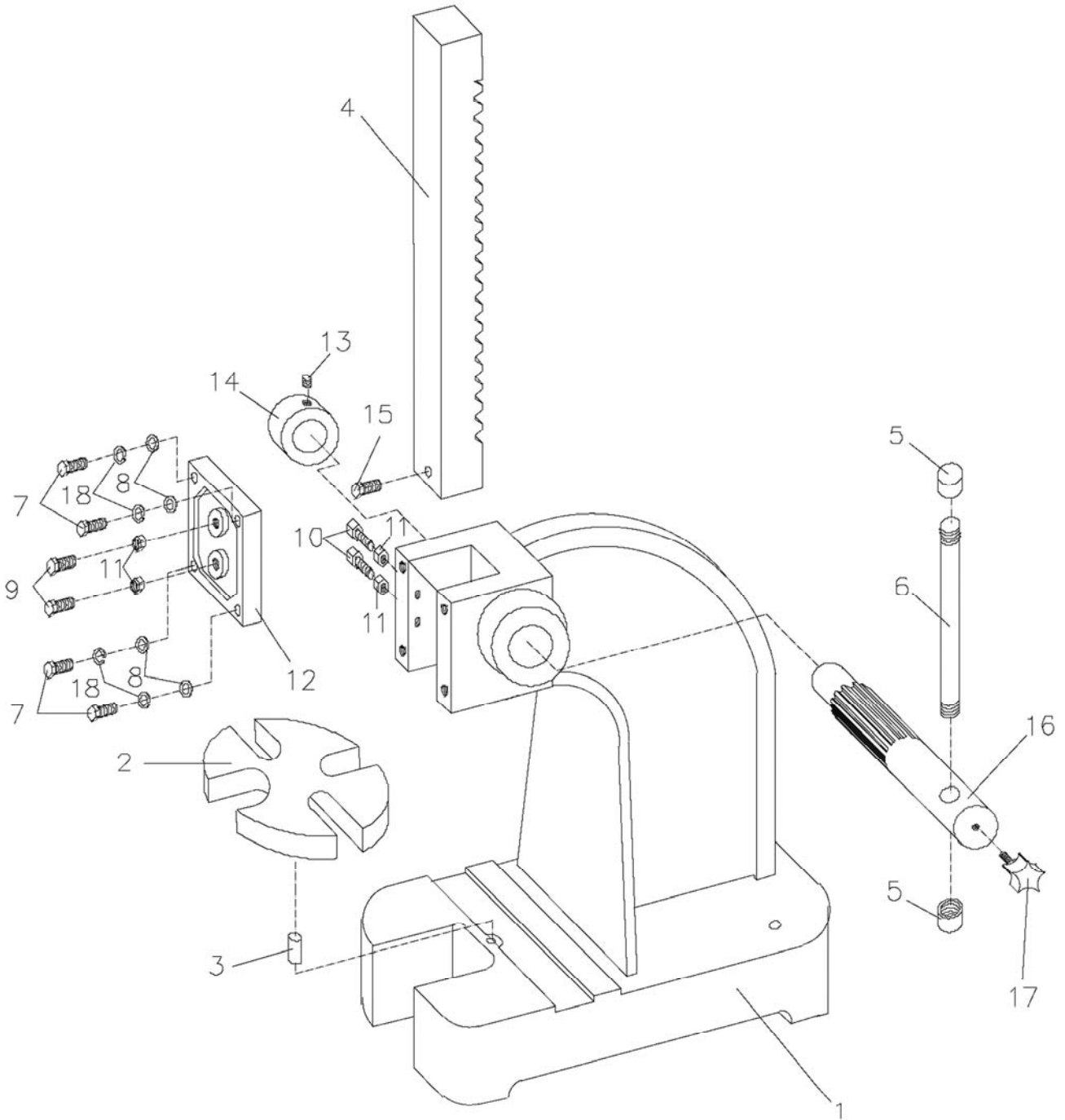

# JET

427 New Sanford Road  
LaVergne, Tennessee 37086  
Ph: 800-274-6848  
www.jettools.com