

Installation / Operating / Maintenance Instructions Filter

Prod. No. 408871, 408872, 408873, 408874, 408875

Specifications

Model	AFM18 AFM14	AFI14 AFI38	AFS12
Port size	1/8, 1/4, 3/8, 1/2		
Max. supply pressure	140 psi (10 bar)		
Installation	Vertical (as shown)		
Medium	Compressed air - Filtered		
Ambient / media temperature	5° - 60° C (41° - 140° F)		
Bowl material	Polycarbonate		

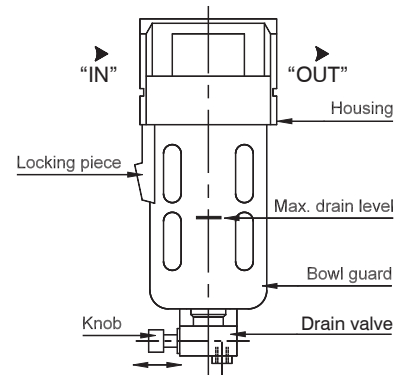

fig. 1

Important

Since this equipment is used in compressed air line, proper precautions are to be taken for safety.

Installation Instructions

1. Install in a clean / acid free environment.
2. Before installation of the unit, check whether the unit is as per the specification - especially the port size and the corresponding fittings to be used on the unit.
3. Flush the piping for dirt, dust, rust and other foreign particles.
4. The arrow mark ► on the top of the housing indicates the flow direction, Inlet ► Outlet (If the unit is connected in the reverse direction the unit will not function properly)
5. Use proper thread seals for (R) taper thread nipple, or face washer for (G) parallel thread nipple.
6. Tighten the piping / nipples to the housing ports using proper tools. Do not over torque when tightening.
7. When using (G) parallel thread nipples, check the length of the thread as below.

Thread Size	Tightening torque, Lb / in (Nm)	Length (L) of thread
G1/4	106 - 125 (12 - 14)	8mm Max.
G3/8	195 - 215 (22 - 24)	9mm Max.
G1/2	250 - 270 (28 - 30)	12mm Max.

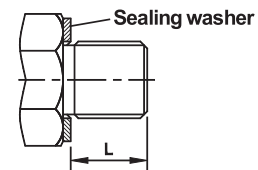

Length of G parallel thread

8. To prevent the condensate splashing all over the place, the M5 thread provided in the drain valve can be used to take the condensate out through tubing.

Operating Instructions

1. For draining the condensate water collected in the bowl (7.1.1), press the knob of the Drain valve (see fig.3).
2. It is advisable to drain the bowl every day. The frequency of draining can be decided based on the condensate collection. However, take care that the condensate level does not cross the " Max. level " marked on the bowlguard.

Maintenance instructions

- a. Before dismantling the unit, exhaust the air in the line completely.
- b. To clean the filter element (5) and the bowl (7.1.1)
- c. Removing the bowl guard (7.3): **(For models AFI14, AFI38, AFS12)** Lift the bowl guard (7.3) upwards, pull down the locking piece (7.3.1). Turn the bowl guard 45° and pull down.
(For models AFM18 and AFM14) unscrew the threaded bowl guard (7.3) in a counter clockwise direction.
Dismantle the components and clean the filter element in kerosene and blow with compressed air. Clean the bowl with soap water or neutral detergent. Do not use thinner, kerosene, petrol, synthetic oil, trichloroethylene or other aromatic hydrocarbons. (Polycarbonate bowl may get damaged and possibly fail if exposed to these solvents).
- d. Check for damages in the 'O' rings (7.1.2), (7.2.3) and other parts. Replace if needed (or) clean and reassemble.
- d. For assembly of the unit: apply NLGI Grade 2 grease on the 'O' rings (7.1.2), (7.2.3) and on the surface of the housing where the 'O' ring enters the housing (1). Reassemble all the components.
- d. Assembling the bowl guard (7.3): **(For models AFI14, AFI38, AFS12)** position the top flange lug portion of the bowl guard (7.3) to the corresponding slots in the housing (1). Push the bowl guard fully into the housing. Turn the bowl guard 45° until the locking piece (7.3.1) enters into the housing slot fully.
(For models AFM18 and AFM14) Screw the threaded bowl guard (7.3) on to the housing (1).

Assembly / Spare Parts List

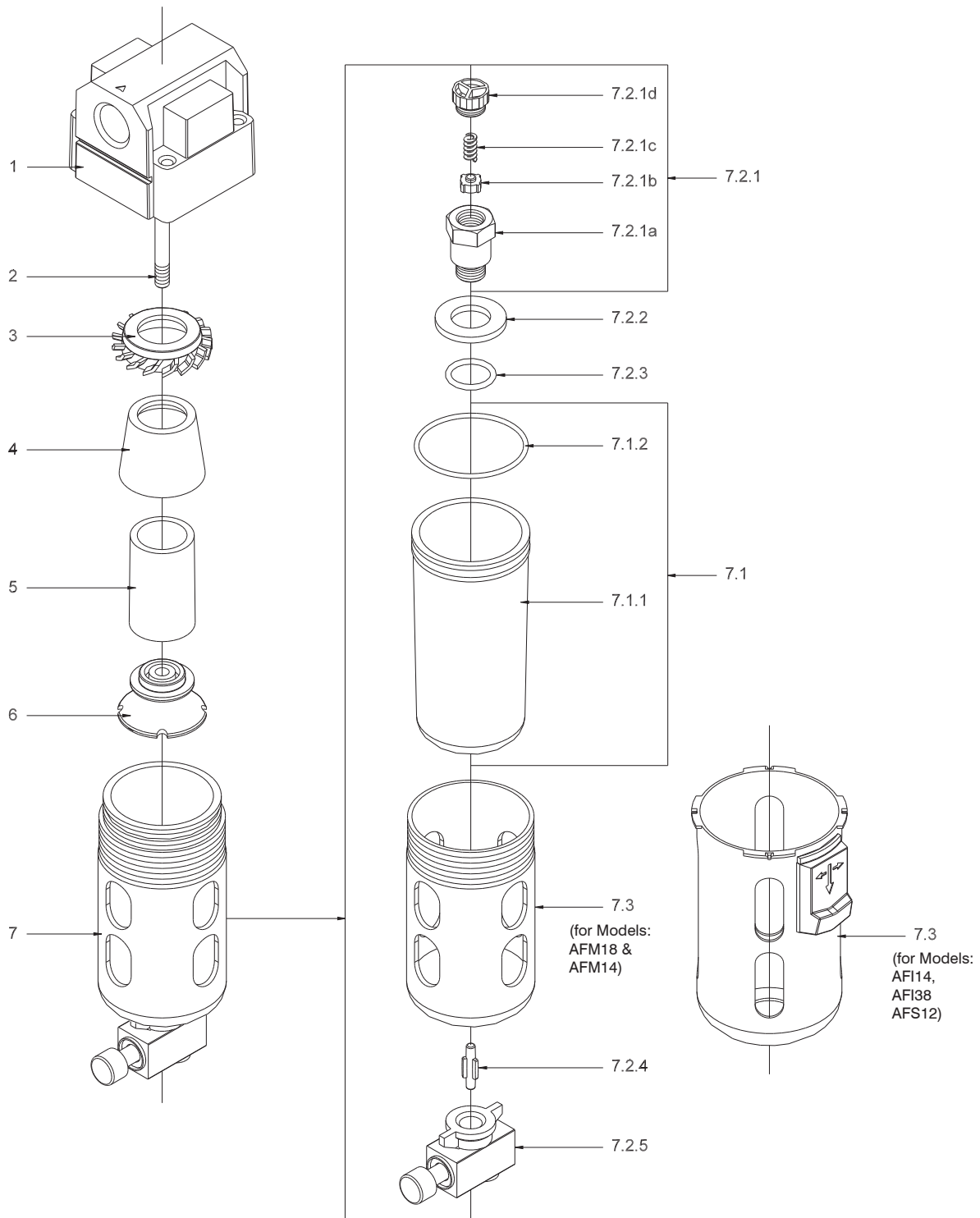

Fig. 2

Spare Parts List Filter

Ref No	No off	Part name / Ref. No	Ordering No. for		
			AFM18 AFM14	AFI14 AFI38	AFS12
		Internal Plastic Spares			
1	1	Housing	-	-	-
2	1	Stud	-	-	-
3	1	Separator	782000	782001	782002
4	1	Shield	762000	762010	762020
5	1	Filter element			
		Filter element - 1 micron	582006	582030	582047
		Filter element - 5 microns	582000	582020	582040
		Filter element - 25 microns	582001	582021	582041
		Filter element - 40 microns	582002	582022	582042
		Filter element - 50 microns	582003	582023	582043
		Filter element - 100 microns	582004	582024	582044
6		Filter holder	712001	712002	712004
7.1	1	Bowl with 'O' ring	LA2000	LA2001	LA2002
7.1.1	1	Bowl	732000	732003	732004
7.1.2	1	'O' ring	650015	650108	650110
7.2	1	Drain valve assembly *	SC2004	SC2004	SC2004
7.2.1	1	Gland assembly	SA2009	SA2009	SA2009
7.2.1a	1	Gland	-	-	-
7.2.1b	1	Valve seat	-	-	-
7.2.1c	1	Spring	-	-	-
7.2.1d	1	Spring guide nut	-	-	-
7.2.2	1	Sealing washer	-	-	-
7.2.3	1	'O' ring	650121	650121	650121
7.2.4	1	Actuator	722001	722001	722001
7.2.5	1	Stem housing assembly	SA2002	SA2002	SA2002

Denotes for ordering items. For example, **Bowl with 'O' ring (7.1)** will be supplied as kit consisting of bowl (7.1.1), 'O' ring 7.1.2 accordingly.

* (7.2 - Drain valve assembly) - Serviceable type

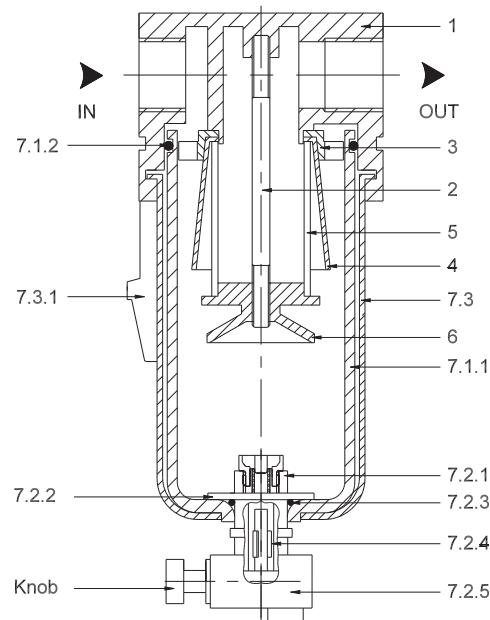

Fig. 3

Trouble shooting

TROUBLE	CAUSE	SOLUTION
1. Restricted air flow	Filter element (5) clogged	Clean the filter element or replace
2. Water level not visible	Dirt on the inner surface of the bowl (7.1.1)	Clean the bowl
3. Air leaks at housing (1) and bowl guard (7.3)	'O' ring (7.1.2) damaged	Replace the 'O' ring
4. Air leaks at the bottom of the bowl (7.1.1)	'O' ring (7.2.3) damaged	Replace
5. Air leaks continuously through the drain valve (7.2)	1. Valve seat damaged (7.2.1b)	1. Replace the drain valve assembly (7.2)
	2. Dust in valve seat (7.2.1b)	2. The valve seat clean & reassemble
6. The knob of drain valve does not return	Valve components stuck	Pull the knob and operate. If the valve gets stuck again - Replace the drain valve assembly (7.2)
7. Leakage in the bowl	Bowl broken	Change the bowl

How to order spare parts:

Mention the spare parts and model numbers as given in the tables.

Example: 'O' ring 650108 for AFM18

Subject to change

Pour l'information en français, visitez notre site Web : www.jetequipment.com/fr/