

# Operation MANUAL

Prod. No.: 409008 Mod. No.: AR14SD

## 1/4" Air Riveter - Super Heavy Duty



### Specifications

- Riveting Capacity: 5/32" (4.0mm) 3/16" (4.8mm) 1/4" (6.4mm) standard blind rivets  
3/16" (4.8mm) and 1/4" (6.4mm) monobolt
- Air consumption: 10.1 cfm
- Pull: 3,520 lbs
- Stroke: 1.02" 26mm
- Air pressure: 90 PSI
- Weight: 3.74 lbs
- Sound Level: 75 dBA
- Vibration Level: 2.5 m/s<sup>2</sup>

### Dimensions (in millimeter)

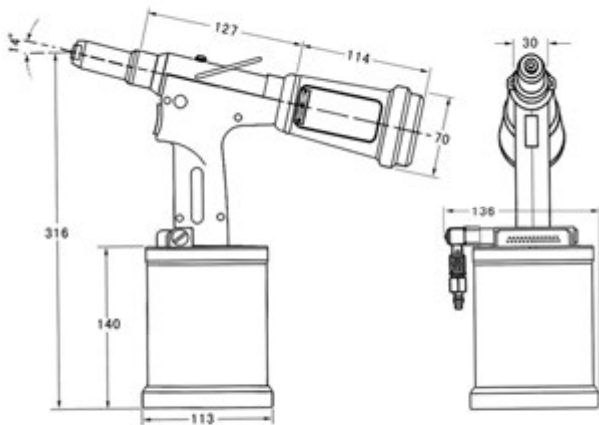

### Important Safety Instructions

This manual contains information that is important for you to know and understand. This information is for YOUR SAFETY and to PREVENT EQUIPMENT PROBLEMS. Prior to operation of the tool, please read the manual.

Never dismantle the tool without first having thoroughly studied the instructions given in this User Manual.

Always use the tool in accordance with the specified safety instructions.

The safety instructions must be made clear to all persons operating this tool.

Never connect the tool to any medium other than compressed air. Set the air pressure to 90 lbs PSI.

The tool must be maintained in a safe working condition at all times and examined at regular intervals for damage and function by trained competent personnel.

Do not dismantle this tool without prior reference to the maintenance and service instructions. Always disconnect the air line from the tool inlet before attempting maintenance and service.

#### CAUTION

**Do not operate the tool if it is directed towards a person or the operator. When using the tool, the wearing of safety glasses is required by the operator and others in the vicinity to protect against rivet stem ejection.**

### Air Supply Requirements

All tools are operated with compressed air at the range of (75-100 PSI). We recommend the use of pressure regulators and filtering systems on the main air supply. These should be fitted within 10-12' of the tool to ensure maximum tool life and minimum tool maintenance. Drain water from air compressor tank and condensation from air lines. See air compressors operation manual.

Air supply hoses should have a minimum working pressure rating of 150% of the maximum pressure produced in the system. Air hoses should be oil resistant, and have an abrasion resistant exterior. Minimum hose size 3/8". Do not use damaged, frayed or deteriorated air hoses and fittings.

### Operation

Determine the size rivet that you are going to use. If setting 1/4" rivets no changes to the tool are necessary the 1/4" nosepiece is factory installed. To change the nosepiece remove it from rivet tool using wrench included. Select nosepiece that corresponds to the size rivet you are using and screw nosepiece clockwise onto rivet tool head.

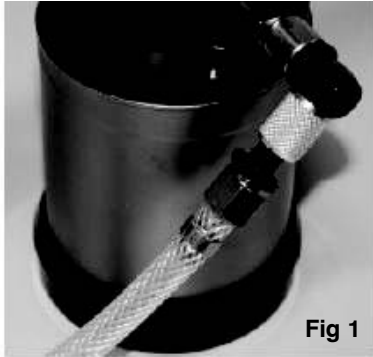

Fig 1

### Operation (con't)

Attach air line to air supply. Turn on the air ON/OFF valve by pushing the deflector ring up. (Fig 1)

Insert a rivet mandrel into nosepiece. The rivet will be held in place by the vacuum. If rivet falls out of the nosepiece, vacuum is not strong enough. To increase amount of suction turn vacuum adjuster nut located on the side of the handle. (Fig 2)

### Lubrication

It is important that the tool be properly lubricated. Every 10,000 cycles the tool should be oiled with lubricating oil. There may be insufficient oil if the stroke of the tool is too small for proper installation. Without proper lubrication the tool will not work properly and parts will wear prematurely.

- 1) Keep the tool upright during operation. Connect the tool to the air supply and turn on the air ON/OFF valve by pushing the deflector ring up. Note: Don't push the trigger.
- 2) Unscrew the oil fill screw from the body using the hex key included. (Fig 3)
- 3) Fill the syringe (included) with hydraulic oil.
- 4) Screw the filled syringe in the oil fill screw hole. Then slowly inject the oil into the tool (Make sure no air is injected.) Adequate oil has been added as soon as resistance is sensed. The excess oil will flow back when the syringe is release if more oil is added than necessary. (Fig 4)
- 5) Unscrew and remove the syringe from the body.
- 6) Screw the oil fill screw into the hole using the hex key.
- 7) Wipe off any excess oil.

### Cleaning Jaws

To access jaws, remove nose housing to expose pulling mechanism and jaw case (Fig 5). To remove jaw case from pulling mechanism, use 2 wrenches (included). Jaws will be under slight spring pressure from the jaw pusher. Separate jaw case (Fig 6) from pusher. Jaws will then be loose. Clean jaws with a wire brush. Place a small dab of multi-purpose lithium grease on outside of jaws (not serrated side). Return jaws into jaw case ensuring proper placement of jaws. All serrated faces should be touching each other.

### Head cleaning

Every 10,000 cycles the jaws of the tool should be cleaned and oiled. Disconnect the air supply and air valve. To access jaws unscrew nose housing then unscrew jaw guide. Jaws will be loose in jaw guide.

Clean jaws, jaw guide, jaw pusher, spring and thread area of the pulling head. Apply lubricant to the outside surface of jaws and inside surface of the jaw guide. Reassemble the head by placing the jaws into the jaw guide. Slide the spring and jaw pusher into the pulling head and screw the jaw guide onto the pulling head.



Fig 2



Fig 3



Fig 4



Fig 5



Fig 6