

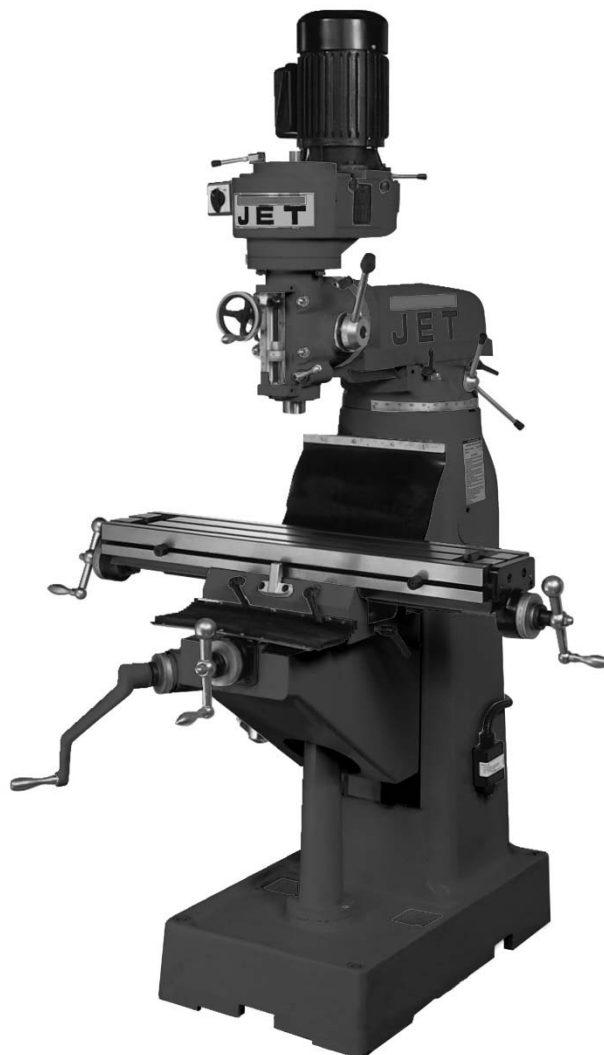

Operating Instructions and Parts Manual

Step-Pulley Turret Mill

Model JVM-836



JET
427 New Sanford Road
LaVergne, Tennessee 37086
Ph.: 800-274-6848
www.jettools.com

Part No. M-690036
Revision D 03/2016
Copyright © 2014 JET

1.0 Warranty and Service

JET warrants every product it sells against manufacturers' defects. If one of our tools needs service or repair, please contact Technical Service by calling 1-800-274-6846, 8AM to 5PM CST, Monday through Friday.

Warranty Period

The general warranty lasts for the time period specified in the literature included with your product or on the official JET branded website.

- JET products carry a limited warranty which varies in duration based upon the product. (See chart below)
- Accessories carry a limited warranty of one year from the date of receipt.
- Consumable items are defined as expendable parts or accessories expected to become inoperable within a reasonable amount of use and are covered by a 90 day limited warranty against manufacturer's defects.

Who is Covered

This warranty covers only the initial purchaser of the product from the date of delivery.

What is Covered

This warranty covers any defects in workmanship or materials subject to the limitations stated below. This warranty does not cover failures due directly or indirectly to misuse, abuse, negligence or accidents, normal wear-and-tear, improper repair, alterations or lack of maintenance. JET woodworking machinery is designed to be used with Wood. Use of these machines in the processing of metal, plastics, or other materials outside recommended guidelines may void the warranty. The exceptions are acrylics and other natural items that are made specifically for wood turning.

Warranty Limitations

Woodworking products with a Five Year Warranty that are used for commercial or industrial purposes default to a Two Year Warranty. Please contact Technical Service at 1-800-274-6846 for further clarification.

How to Get Technical Support

Please contact Technical Service by calling 1-800-274-6846. **Please note that you will be asked to provide proof of initial purchase when calling.** If a product requires further inspection, the Technical Service representative will explain and assist with any additional action needed. JET has Authorized Service Centers located throughout the United States. For the name of an Authorized Service Center in your area call 1-800-274-6846 or use the Service Center Locator on the JET website.

More Information

JET is constantly adding new products. For complete, up-to-date product information, check with your local distributor or visit the JET website.

How State Law Applies

This warranty gives you specific legal rights, subject to applicable state law.

Limitations on This Warranty

JET LIMITS ALL IMPLIED WARRANTIES TO THE PERIOD OF THE LIMITED WARRANTY FOR EACH PRODUCT. EXCEPT AS STATED HEREIN, ANY IMPLIED WARRANTIES OF MERCHANTABILITY AND FITNESS FOR A PARTICULAR PURPOSE ARE EXCLUDED. SOME STATES DO NOT ALLOW LIMITATIONS ON HOW LONG AN IMPLIED WARRANTY LASTS, SO THE ABOVE LIMITATION MAY NOT APPLY TO YOU.

JET SHALL IN NO EVENT BE LIABLE FOR DEATH, INJURIES TO PERSONS OR PROPERTY, OR FOR INCIDENTAL, CONTINGENT, SPECIAL, OR CONSEQUENTIAL DAMAGES ARISING FROM THE USE OF OUR PRODUCTS. SOME STATES DO NOT ALLOW THE EXCLUSION OR LIMITATION OF INCIDENTAL OR CONSEQUENTIAL DAMAGES, SO THE ABOVE LIMITATION OR EXCLUSION MAY NOT APPLY TO YOU.

JET sells through distributors only. The specifications listed in JET printed materials and on official JET website are given as general information and are not binding. JET reserves the right to effect at any time, without prior notice, those alterations to parts, fittings, and accessory equipment which they may deem necessary for any reason whatsoever. JET® branded products are not sold in Canada by JPW Industries, Inc.

Product Listing with Warranty Period

90 Days – Parts; Consumable items
1 Year – Motors; Machine Accessories
2 Year – Metalworking Machinery; Electric Hoists, Electric Hoist Accessories; Woodworking Machinery used for industrial or commercial purposes
5 Year – Woodworking Machinery
Limited Lifetime – JET Parallel clamps; VOLT Series Electric Hoists; Manual Hoists; Manual Hoist Accessories; Shop Tools; Warehouse & Dock products; Hand Tools; Air Tools

NOTE: JET is a division of JPW Industries, Inc. References in this document to JET also apply to JPW Industries, Inc., or any of its successors in interest to the JET brand.

2.0 Table of contents

Section	Page
1.0 Warranty and Service.....	2
2.0 Table of contents.....	3
3.0 Safety warnings.....	4
4.0 About this manual	5
5.0 Specifications	6
6.0 JVM-836 Installation Layout.....	7
7.0 Setup and Assembly	8
7.1 Unpacking	8
7.2 Contents of shipping container	8
7.3 Site preparation	9
7.4 Lifting the mill	9
7.5 Completing assembly	9
7.6 Lubrication.....	10
8.0 Electrical connections	10
8.1 Conversion from 115V to 230V (JVM-836-1 only).....	10
8.2 Wire Sizes	11
9.0 Controls.....	11
10.0 Operation	12
10.1 Precautions	12
10.2 Clamping work piece to table	12
10.3 Changing speeds	12
10.4 Fine feed	12
10.5 Draw bar operation; changing tooling.....	13
11.0 Adjustments	13
11.1 Head movement: left and right	13
11.2 Positioning ram.....	14
11.3 Gib adjustment	14
11.4 Ram wear plate adjustment.....	14
11.5 Table lead screw backlash adjustment	14
12.0 Speed charts for JVM-836	16
13.0 Replacement Parts.....	16
13.1.1 JVM-836 Head Assembly – Exploded View	17
13.1.3 JVM-836 Head Assembly – Parts List.....	18
13.2.1 JVM-836 Upper Head Assembly – Exploded View	20
13.2.2 JVM-836 Upper Head Assembly – Parts List	21
13.3.1 JVM-836 Leadscrew Assembly – Exploded View	23
13.3.2 JVM-836 Leadscrew Assembly – Parts List	24
13.4.1 JVM-836 Base Assembly – Exploded View	25
13.4.2 JVM-836 Base Assembly – Parts List	26
13.5.1 JVM-836 One Shot Lubrication System – Exploded View	28
13.5.2 One Shot Lubrication System – Parts List.....	28
14.0 Electrical Connections for JVM-836.....	29



3.0 Safety warnings

1. Read and understand the entire owner's manual before attempting assembly or operation.
2. Read and understand the warnings posted on the machine and in this manual. Failure to comply with all of these warnings may cause serious injury.
3. Replace the warning labels if they become obscured or removed.
4. This turret mill is designed and intended for use by properly trained and experienced personnel only. If you are not familiar with the proper and safe operation of a turret mill, do not use until proper training and knowledge have been obtained.
5. Do not use this turret mill for other than its intended use. If used for other purposes, JET disclaims any real or implied warranty and holds itself harmless from any injury that may result from that use.
6. Always wear approved safety glasses/face shields while using this mill. Everyday eyeglasses only have impact resistant lenses; they are not safety glasses.
7. Before operating this machine, remove tie, rings, watches and other jewelry, and roll sleeves up past the elbows. Remove all loose clothing and confine long hair.
8. Non-slip safety footwear and anti-skid floor strips are recommended. Do not wear gloves.
9. Never place hands near or around a revolving tool or part.
10. Wear ear protectors (plugs or muffs) during extended periods of operation.
11. Some dust created by power sanding, sawing, grinding, drilling and other construction activities contain chemicals known to cause cancer, birth defects or other reproductive harm. Some examples of these chemicals are:
 - Lead from lead based paint.
 - Crystalline silica from bricks, cement and other masonry products.
 - Arsenic and chromium from chemically treated lumber.

Your risk of exposure varies, depending on how often you do this type of work. To reduce your exposure to these chemicals, work in a well-ventilated area and work with approved safety equipment, such as face or dust masks

that are specifically designed to filter out microscopic particles.

12. Do not operate this machine while tired or under the influence of drugs, alcohol or any medication.
13. Make certain the switch is in the OFF position before connecting the machine to the power supply.
14. Make certain the machine is properly grounded.
15. Make all machine adjustments or maintenance with the machine unplugged from the power source.
16. Workpiece must be attached or clamped to the table. Never hold a workpiece with your hand.
17. Use correct spindle speed and table feed for the particular job.
18. Do not start machine with cutter in contact with workpiece.
19. Disengage power feed when not in use.
20. Remove adjusting keys and wrenches. Form a habit of checking to see that keys and adjusting wrenches are removed from the machine before turning it on.
21. Keep safety guards in place at all times when the machine is in use. If removed for maintenance purposes, use extreme caution and replace the guards immediately after completion of maintenance.
22. Check damaged parts. Before further use of the machine, a guard or other part that is damaged should be carefully checked to determine that it will operate properly and perform its intended function. Check for alignment of moving parts, binding of moving parts, breakage of parts, mounting and any other conditions that may affect its operation. A guard or other part that is damaged should be properly repaired or replaced.
23. Provide for adequate space surrounding work area and non-glare, overhead lighting.
24. Keep the floor around the machine clean and free of scrap material, oil and grease.
25. Keep visitors a safe distance from the work area. Keep children away.
26. Make your workshop child proof with padlocks, master switches or by removing starter keys.
27. Give your work undivided attention. Looking around, carrying on a conversation and "horse-play" are careless acts that can result in serious injury.

28. Maintain a balanced stance at all times so that you do not fall or lean against the cutter or other moving parts. Do not overreach or use excessive force to perform any machine operation.
29. Use the right tool at the correct speed and feed rate. Rotate spindle clockwise for right-hand tools, counterclockwise for left-hand tools. Do not force a tool or attachment to do a job for which it was not designed. The right tool will do the job better and more safely.
30. Use recommended accessories; improper accessories may be hazardous.
31. Frequently clean this machine. Maintain tools with care. Keep cutters sharp and clean for the best and safest performance. Follow instructions for lubricating and changing accessories.
32. Turn off the machine before cleaning. Use a brush or compressed air to remove chips or debris — do not use your hands.
33. Do not stand on the machine. Serious injury could occur if the machine tips over.
34. Never leave the machine running unattended. Turn the power off and do not leave the machine until it comes to a complete stop.
35. Remove loose items and unnecessary work pieces from the area before starting the machine.
36. Don't use in dangerous environment. Don't use this machine in damp or wet locations, or expose it to rain. Keep work area well lighted.
37. Some coolants used for machining contain chemicals that may be hazardous to your health if not used properly. Read and understand all user information listed on the coolant container and protect yourself accordingly.

Familiarize yourself with the following safety notices used in this manual:

CAUTION This means that if precautions are not heeded, it may result in minor injury and/or possible machine damage.

WARNING This means that if precautions are not heeded, it may result in serious, or possibly even fatal, injury.

4.0 About this manual

This manual is provided by JET, covering the safe operation and maintenance procedures for a JET Model JVM-836 Turret Mill. This manual contains instructions on installation, safety precautions, general operating procedures, maintenance instructions and parts breakdown. Your machine has been designed and constructed to provide consistent, long-term operation if used in accordance with the instructions set forth in this document.

If there are questions or comments, please contact your local supplier or JET. JET can also be reached at our web site: www.jettools.com.

Retain this manual for future reference. If the machine transfers ownership, the manual should accompany it.

WARNING **Read and understand the entire contents of this manual before attempting assembly or operation! Failure to comply may cause serious injury!**

5.0 Specifications

Model Number.....	JVM-836-1.....	JVM-836-3
Stock Number.....	690036	690038

Motor and Electricals:

Motor type	TEFC induction.....	TEFC induction
Horsepower	1-1/2.....	1-1/2
Phase.....	1.....	3
Voltage.....	115/230V (prewired 115V).....	230V only
Cycle.....	60Hz.....	60Hz
Listed FLA (full load amps).....	18/9.....	4.7/5.7
Power Transfer	belt.....	belt
Motor Speed.....	1720 RPM.....	1720/840 RPM
Sound Emission (tested at 3 ft. from machine):		
Without load.....	75 dB.....	75 dB
With load.....	80-85 dB.....	80-85 dB

Head and Spindle:

Spindle Taper	R-8.....	R-8
Quill Diameter.....	3-3/8".....	3-3/8"
Number of Spindle Speeds.....	5.....	10
Range of Spindle Speeds.....	240-1550.....	120-1550
Spindle Travel	5".....	5"
Head Movement	90° L and R.....	90° L and R
Maximum Distance Spindle to Table.....	13-3/4".....	13-3/4"
Maximum Distance Spindle to Column	15-3/4".....	15-3/4"
Minimum Distance Spindle to Column	5-1/4".....	5-1/4"
Collet Capacity	1/8" – 7/8".....	1/8" – 7/8"
Ram Travel.....	10-1/2".....	10-1/2"
Ram Rotation	90° L and R.....	90° L and R

Table:

Table Size	7-7/8 x 35-3/4".....	7-7/8 x 35-3/4"
Longitudinal Table Travel.....	22-1/4".....	22-1/4"
Table Cross Travel	9-1/2".....	9-1/2"
T-Slots, Number	3.....	3
T-Slots, Size.....	.5/8".....	.5/8"
T-Slots, Spacing	2-1/2".....	2-1/2"
Table Weight Capacity	500 lb.....	500 lb
Knee Travel.....	14".....	14"

Dimensions:

Overall Dimensions, assembled	55"W x 52"D x 77"H.....	55"W x 52"D x 77"H
Shipping Dimensions	67"W x 56"D x 66"H.....	67"W x 56"D x 66"H

Weights:

Net Weight (approx.).....	1617 lb.....	1610 lb
Shipping Weight (approx).....	1700 lb.....	1700 lb

The specifications in this manual were current at time of publication, but because of our policy of continuous improvement, JET reserves the right to change specifications at any time and without prior notice, without incurring obligations.

6.0 JVM-836 Installation Layout

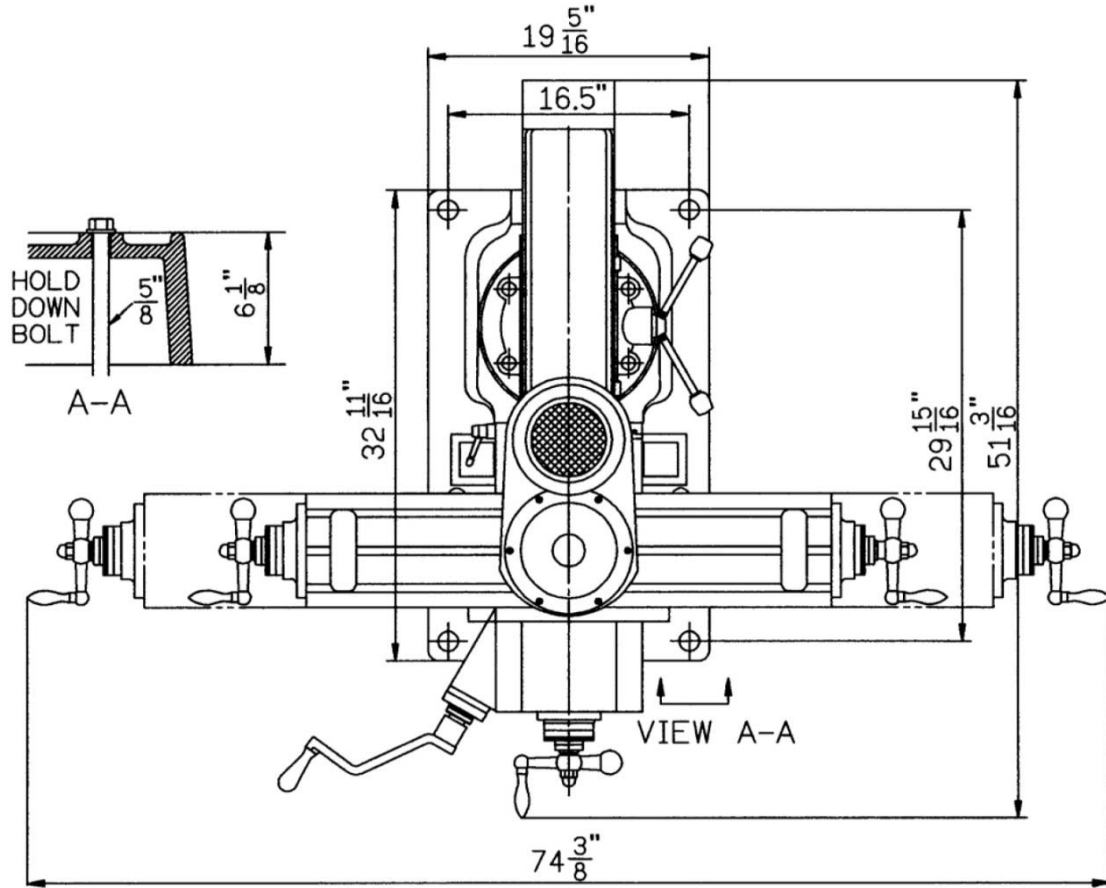

Figure 1

7.0 Setup and Assembly

7.1 Unpacking

Open shipping container and check for shipping damage. Report any damage immediately to your distributor and shipping agent. Do not discard any shipping material until the Turret Mill is assembled and running properly.

Compare the contents of your container with the following parts list to make sure all parts are intact. Missing parts, if any, should be reported to your distributor. Read the instruction manual thoroughly for assembly, maintenance and safety instructions.

NOTE: Some parts shown below may have come pre-installed on the mill.

7.2 Contents of shipping container

Refer to Figure 2.

- 1 Turret Mill (not shown)
- 1 Flat Way Cover (rear)
- 1 Pleated Way Cover (front)
- 1 Knee Crank
- 1 Draw Bar
- 4 Handles
- 1 Tool Box, containing:
 - 1 Hex Key Set (1.5-10mm)
 - 1 17/19mm Box Wrench
 - 1 Cross Point Screw Driver #2
 - 1 Flat Blade Screw Driver #2
 - 1 Plastic Oil Bottle
 - 1 Handwheel
 - 1 Adjustable Wrench
 - 1 Operator's Manual (not shown)
 - 1 Warranty Card (not shown)



Figure 2: shipping contents

NOTE: If your mill is supplied with an optional Table Powerfeed and/or Digital Readout, be sure to consult the separate instruction materials that accompany them.

7.3 Site preparation

The mill must be placed on an even surface and bolted to the floor. Anchor bolts of sufficient size and length must be fastened to the floor according to the mill's footprint. See the site installation diagram in Figure 1.

7.4 Lifting the mill

Finish removing the sides of the crate. Leave mill bolted to pallet until ready to move to its final location.

The preferred method for lifting mill is with a hook through the hoisting ring which is mounted atop the ram. Steady the mill to prevent it from spinning.

An alternate method for lifting mill is with a sling. Refer to Figure 3 for proper position of sling under ram. Note position of ram and that table has been moved against column. Tighten ram locking bolts (A, Figure 3) before lifting.

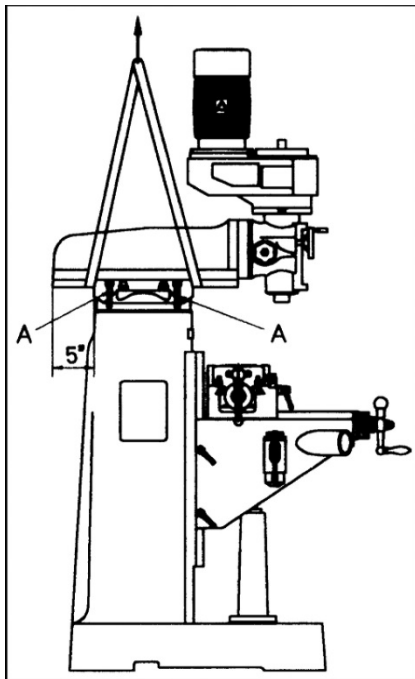

Figure 3: sling location

WARNING Keep people a safe distance away while mill is being moved.

Carefully lift mill and move to a position over the anchor bolts. Lower mill over anchor bolts and check for level, with a machinist's level placed on the table. Mill must be level back to front and side to side. Shim if necessary, but remember that mill must be supported equally at all four corners. Check for level before tightening anchor bolt nuts, and check again after tightening them.

It is advisable when placing the mill on a concrete floor to use grout (thin mortar) to correct any unevenness in the concrete and provide a solid foundation at all points.

CAUTION Mill must be supported equally under all four corners. Failure to comply may cause the column to twist and put a bind in the ways.

7.5 Completing assembly

(Note: If the mill head is already upright, skip to step 5 below. Otherwise, begin with step 1.)

CAUTION Before attempting to raise mill head, familiarize yourself with instructions in *section 11.1*, for procedures to safely raise and set up the mill head.

1. Remove handwheel (A, Figure 4).
2. Loosen four hexagonal nuts (B, Figure 4) about 1/2 turn each counterclockwise, just enough to allow rotation of head. **Do not** remove these nuts unless you are prepared to remove the head.
3. Apply upward pressure on motor by hand to relieve pressure on worm mechanism, and use a 19mm socket and breaker bar to turn worm nut (C, Figure 4) and raise head to upright position.
4. Slightly tighten nuts (B, Figure 4); not torqued, just snug for now. *Before operating mill, follow procedures in section 11.1 to verify angle settings and properly tighten the four nuts.*

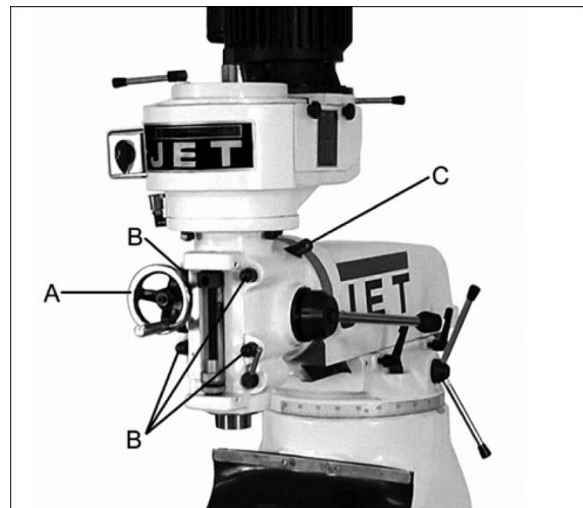

Figure 4

5. Use mineral spirits, kerosene or other cleaning solvent, to remove all rust-proofing from where it may have been applied. This is important; moving the table or any other components before removing rust proofing will only put rust proofing where you don't want it. Do not use gasoline, paint thinner, or lacquer thinner; these will damage painted surfaces.

6. Lubricate exposed ways (see sect. 7.6), then move each unit (table and ram) to the opposite limit stop, and clean and lubricate the newly exposed ways. Loosen bolts to unlock ram and move it forward and backward to the full length in order to clean and lubricate.
7. Cover all machined surfaces with a film of light machine tool oil to inhibit rust.
8. Remove wood block from below knee.

Some of the following steps may have already been performed on the machine. If so, ignore the instructions related to those particular steps. Otherwise, perform them in the order listed.

9. Install the two table traverse handles and one cross-feed handle on their respective shafts. Tighten each handle using a wrench on the flats.
10. Remove any rust proofing from drawbar. Install drawbar with its washer into spindle center through top of head assembly. When installing tool into spindle, lock spindle and tighten drawbar using provided wrench.
11. Slide the fine feed handwheel over the hub and push it back until its roll pin engages hole in hub, and handwheel is flush with hub surface.
12. Place coarse feed handle on feed shaft, aligning roll pin with a hole. Tap handle lightly until it is flush against hub surface.
13. Install elevating (knee) crank on its shaft.
14. Install rubber way covers at front and behind table.

7.6 Lubrication

CAUTION Do not operate this milling machine before fully lubricating it. Failure to comply may damage machine.

Refer to Figure 5.

- A. Spindle bearings – Fill oil cup once daily with Mobil DTE® Oil Light.
- B. Oil Pump – Fill reservoir as needed by removing cap on top of tank and filling with Mobil Vactra Oil No. 2. Pump oil release handle once for every hour of operation. Way surfaces and leadscrews are lubricated in this manner.
- C. Knee Leadscrew – Lubricate with Mobilith® AW2 once a week.

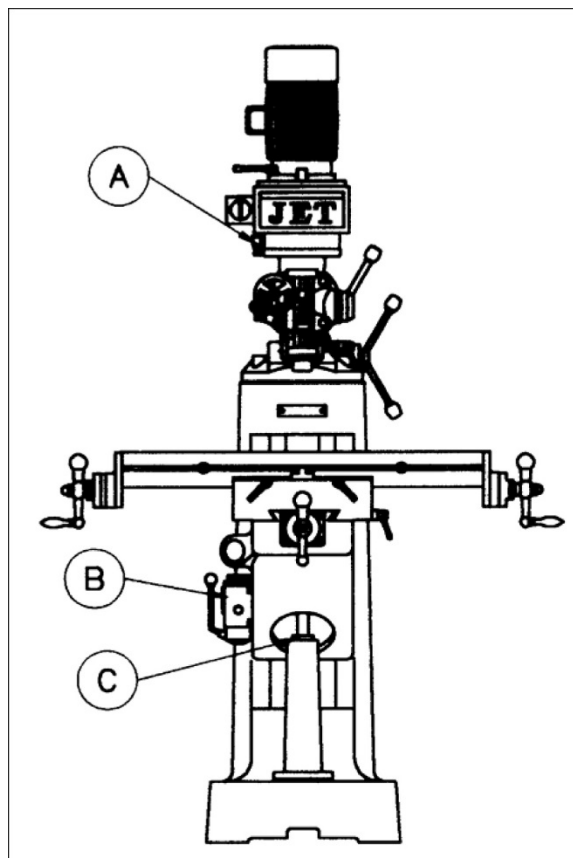

Figure 5: Lubrication

8.0 Electrical connections

WARNING All electrical connections must be made by a qualified electrician in compliance with all relevant codes. This machine must be properly grounded. Failure to comply may result in serious injury.

Confirm that power at the site matches power requirements of the mill before connecting to power source.

8.1 Conversion from 115V to 230V (JVM-836-1 only)

To convert from 115V to 230V operation, remove junction box cover on motor and change the wires according to diagram found on inside of cover.

Similar diagrams are found in section 14.0 of this manual. Note: If discrepancies arise, diagrams on machine take precedence.

8.2 Wire Sizes

CAUTION

For circuits which are far away from the electrical service box, the wire size must be increased in order to deliver ample voltage to the motor.

To minimize power losses and to prevent motor overheating and burnout, the use of wire sizes for branch circuits or electrical extension cords according to the following table is recommended:

Conductor Length	AWG Number	
	230/460 Volt Lines	120 Volt Lines
0 – 50 Ft.	No. 14	No. 14
50 – 100 Ft.	No. 14	No. 12
Over 100 Ft.	No. 12	No. 8

Table 1

9.0 Controls

Refer to Figures 6 through 8:

- A. **Belt Cover Lock Knobs** (A, Figure 6) – Loosen and remove belt cover to change belt position on the pulleys.

WARNING

Disconnect mill from power source before changing belt position. Reinstall belt cover before operating mill.

- B. **Spindle Brake** (B, Figure 6) – Move in either direction to stop spindle once power has been turned off.
- C. **Coarse Feed Handle** (C, Figure 6) – Rotate counterclockwise to lower spindle. Return spring will automatically retract spindle once handle is released. Handle can be removed when not in use.
- D. **Quill Lock** (D, Figure 7) – Rotate handle clockwise to lock quill in position; counterclockwise to release.
- E. **Micrometer Adjusting Nut** (E, Figure 6) – For setting specific spindle depth. Each graduation on the nut represents 0.001" of depth, and corresponds to the adjacent scale.
- F. **Manual Fine Feed Handwheel** (F, Figure 6) – Must engage fine feed (I, Figure 7) for handwheel to function.
- G. **Quill Stop** (G, Figure 6) – Used in conjunction with micrometer adjusting nut for predetermined depth.
- H. **Reversing Switch** (H, Figure 7) – Switches rotation of spindle. For 3-phase motor, there is an additional low and high-speed option.

- I. **Fine Feed Engagement** (I, Figure 7) – Turn clockwise until tight. This engages the manual fine feed; counterclockwise to release.
- J. **Draw Bar** (J, Figure 7) – Located at top of head. This is used to tighten an R-8 collet or R-8 tool into the quill. Tighten draw bar enough to hold tool securely during milling operations.
- K. **Longitudinal Movement** (K, Figure 8) – Handles located on opposite ends of table. This controls the X-axis.
- L. **Cross Movement** (L, Figure 8) – Handle located directly in front of machine. This controls the Y-axis.
- M. **Knee Handle** (M, Figure 8) – Raises the table up and down.
- N. **Belt Tension Lever** (N, Figure 6) – Slides motor pulley to release tension on belt.

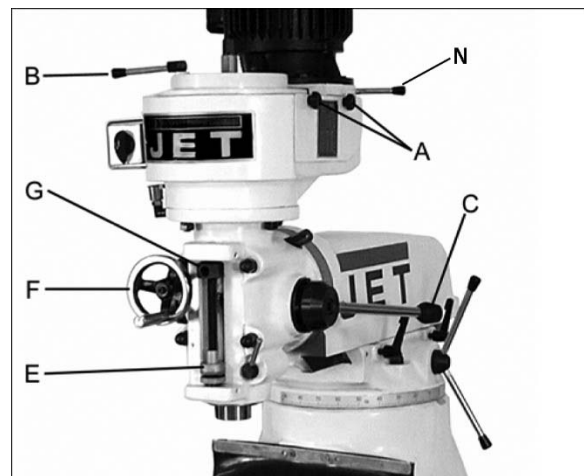

Figure 6: controls

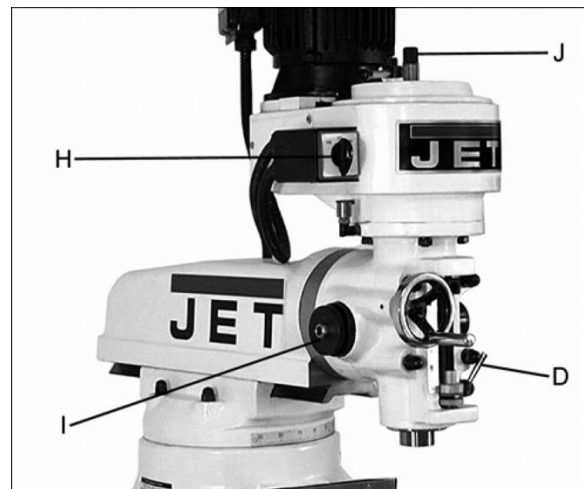

Figure 7: controls

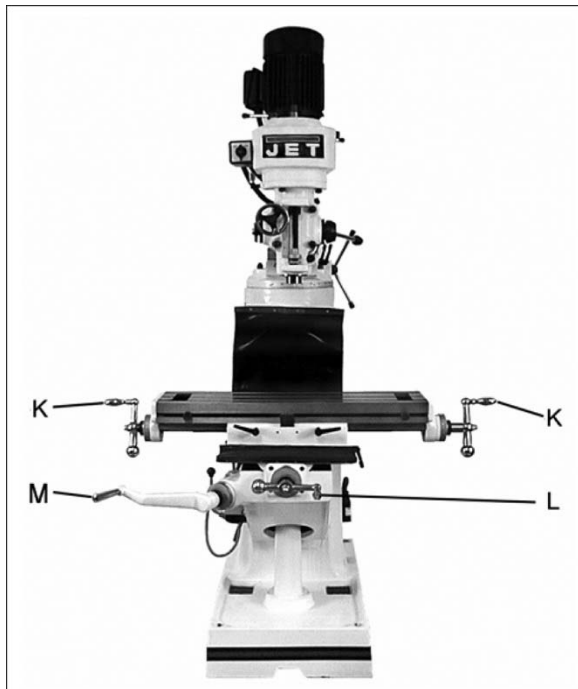

Figure 8: controls

10.0 Operation

10.1 Precautions

CAUTION Observe the following instructions before using this mill.

1. Verify that spindle brake is released before starting motor.
2. If using longitudinal table travel only, clamp saddle and knee in place using the locking handles; this will add rigidity and provide for heavier cuts with minimal vibration. If not using longitudinal travel, keep table locking handles tightened.
3. On heavy milling work, keep head as close to column as possible to obtain maximum rigidity. Always tighten ram locking handles securely.

10.2 Clamping work piece to table

The table has 5/8-inch T-slots for clamping work pieces to table.

1. Set switch to OFF position.
2. Place work piece on table.
3. Clamp work piece using T-slot clamps, studs, and step blocks as required (Figure 9).

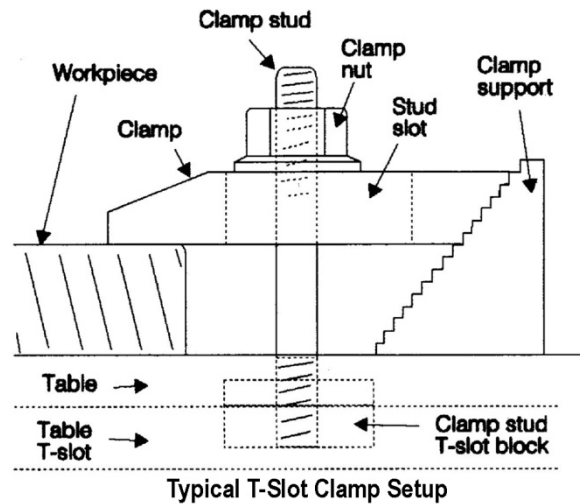

Figure 9

10.3 Changing speeds

1. Unscrew two knobs (A, Figure 7) and remove belt cover.
2. Loosen hex nut (A, Figure 10).
3. Release tension from belt by moving lever (B, Figure 10).
4. Move belt to desired position, by referring to speed chart on the belt cover. (Chart also found in section 12.0 of this manual.)
5. Re-tension the belt using lever (B, Figure 10).
6. Tighten hex nut.
7. Reinstall belt cover.

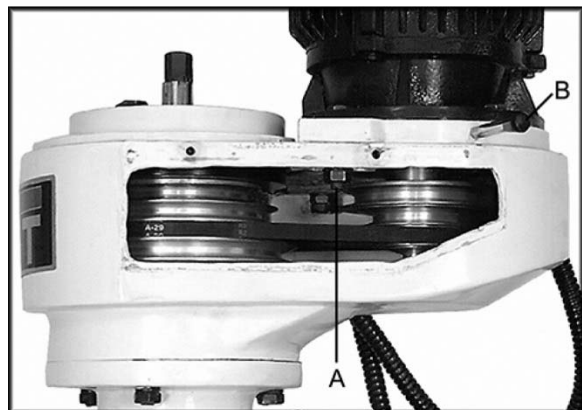

Figure 10: changing speeds

NOTE: The 3-phase motor has an additional high and low-speed setting (H, Figure 7).

10.4 Fine feed

1. Engage fine feed by rotating knurled nut (I, Figure 7) clockwise until tight. The handwheel (F, Figure 6) can now be used to raise and lower the spindle.
2. Disengage fine feed by rotating the knurled nut counterclockwise.

Note: Due to variables in tool diameter, coatings, coolant, and materials, no specific spindle speed or feed rate recommendations are provided. Use general shop manuals that have data applicable to the milling and drilling operations being performed; or contact the supplier of the tooling, coolant, and material for specific recommendations.

10.5 Draw bar operation; changing tooling

The drawbar has 7/16"-20 right hand threads and should be tightened with normal pressure using the provided wrench. To remove a tool:

1. Lock spindle by turning spindle brake (B, Figure 6) left or right.
2. Use provided wrench to loosen draw bar two or three turns (counterclockwise).
3. If collet does not open immediately, tap the top of draw bar with a soft-faced hammer to loosen collet from taper.
4. Remove tool from collet.
5. Insert new tool into collet.
6. Tighten draw bar firmly using provided wrench. The tool is now ready for use.
7. Release spindle brake.

11.0 Adjustments

11.1 Head movement: left and right

⚠WARNING Make sure machine base is secured to floor before repositioning mill head. The center of gravity can shift enough to cause machine to tip over, resulting in serious injury to operator and damage to machine.

1. Loosen four large hex nuts (A, Figure 11) that secure mill head to ram adapter. One-quarter (1/4) turn should be sufficient to allow head to move.

NOTE: For angles greater than 10 degrees, use your free hand to support mill head, relieving weight off the brass worm gears. Doing so will lengthen life of worm gears.

2. Turn worm nut (B, Figure 11) to tilt head left or right as required. Use scale on ram adapter to establish angle.

NOTE: The scales on ram adapter and for head rotation are guides only. Close tolerance work will require use of a dial indicator to make sure head is 90° to table in X and Y axes. Please note the table is fitted to be slightly higher in front, usually about 0.0005".

⚠CAUTION Be sure to apply torque in two steps using a crossing pattern. Failure to do so could distort the face of the ram adapter.

3. Tighten the four hex nuts. Tighten in two steps using a calibrated torque wrench. Use a crossing pattern to tighten the nuts. Tighten initially to 25 foot-pounds.

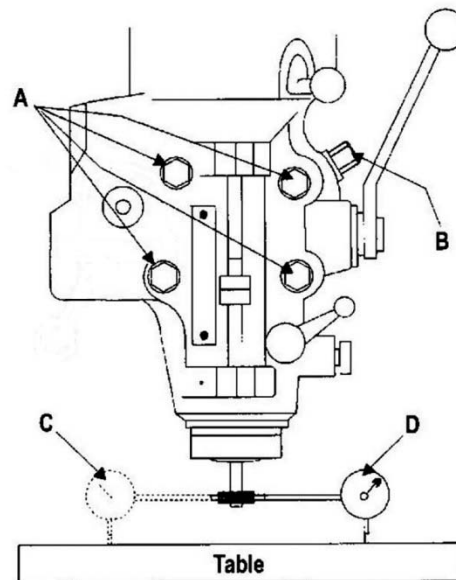

Figure 11: head movement

4. Before applying final torque, check to make sure mill head is perpendicular to worktable.
5. Set up a dial indicator in a collet (see Figure 11) and secure using draw bar.
6. Put spindle drive in neutral.
7. Set the dial indicator plunger on the worktable. Zero indicator.
8. Rotate spindle 180 degrees (when rotating, raise dial indicator plunger by hand to prevent it from dropping into table T-slots).
9. Read dial indicator – it should read zero. If not, loosen the four hex nuts and reposition mill head.
10. Recheck perpendicularity using dial indicator. Repeat the above procedure until dial indicator reads zero in both positions.
11. Tighten the four hex nuts. Tighten in two steps using a calibrated torque wrench. Use a crossing pattern to tighten the nuts. Tighten initially to 25 foot-pounds, then tighten to final torque of 50 foot-pounds. NOTE: Do not overtighten, as it may cause binding of quill.

⚠CAUTION Be sure to apply torque in two steps using a crossing pattern. Failure to do so could distort the face of the ram adapter.

11.2 Positioning ram

11.2.1 Sliding ram fore and aft

CAUTION Care should be taken to lock ram securely after setting.

1. Loosen two handles (A, Figure 12) that lock ram to its ways.

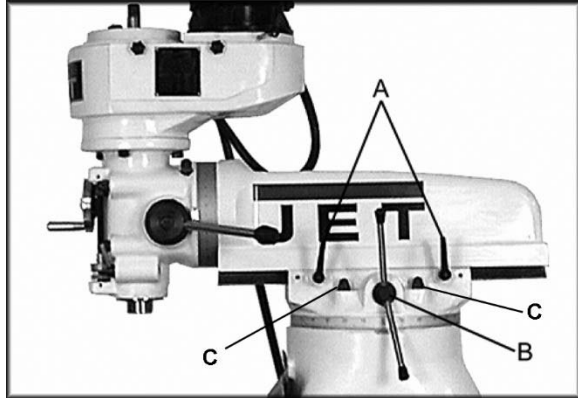

Figure 12: Ram positioning

2. Turn handle (B, Figure 12) to move ram on its ways.
3. When desired position is reached, tighten handles (A) securely.

Note: It is recommended while performing heavy milling work, that the head be left as close to the face of turret as possible. Maximum rigidity is then obtained.

11.2.2 Rotating ram on its turret

WARNING Make sure machine base is secured to floor before repositioning ram. The center of gravity can shift enough to cause machine to tip over, resulting in serious injury to operator and damage to machine.

1. Loosen four turret lock bolts (C, Figure 12). One-half (1/2) turn should be sufficient to allow turret to move. **Note:** Use gentle hand pressure to avoid rapid movement.
2. Turn ram until spindle is in desired position. Use scale on turret to establish turn degree.
3. Tighten four turret lock bolts (C, Figure 12).

11.3 Gib adjustment

The table, saddle and knee are equipped with adjustable gibs. The gibs may require adjustment if unusual vibration is noted when locking mechanisms are off, or if you experience unusual vibration when spindle speed, tooth pitch or depth of cut do not account for the vibration.

NOTE: When adjusting gibs, always start with the knee first; adjust the saddle second, and adjust the table last.

11.3.1 Knee gib

Loosen the two knee locking handles. The knee gib adjustment screw (A, Figure 13) is located under the chip wiper at rear of knee where it contacts the column. Remove way cover and wiper to expose gib adjustment screw. Tighten screw until slight drag is felt when turning knee crank.

11.3.2 Saddle gib

Loosen saddle locking handle. The saddle gib adjustment screw is on the left front of saddle (B, Figure 13). Tighten screw until slight drag is felt when turning cross-feed crank.

11.3.3 Table gib

Loosen table locking handles. The table gib adjustment screw (C, Figure 13) is on the left-hand side, beneath table. Tighten screw until slight drag is felt when turning longitudinal table cranks.



Figure 13: Gib locations

11.4 Ram wear plate adjustment

1. Loosen two hex nuts and adjust the two set screws as needed (#19, 19-1, sect. 13.4.1).
2. Use a dial indicator to measure the amount of movement in the ram. Adjust the wear plate (#10, sect. 13.4.1) until the indicator reading is within 0.003".
3. Retighten hex nuts.

11.5 Table lead screw backlash adjustment

Refer to Figure 14.

The milling machine table is moved by a lead screw and nut for each machine axis. For proper operation, there must be clearance between lead screw and nut, which results in backlash. A second feed screw nut is provided to eliminate most of the backlash. The following procedures provide instructions for obtaining acceptable backlash.

11.5.1 Cross feed backlash adjustment

Refer to Figure 14:

1. Use cross feed crank to move table to extreme rear of its travel (toward column).
2. Remove pleated way cover.
3. Open the two chip guards (#77,78, sect. 13.4.1) enough to expose cross feed adjustment nut (the nut toward rear of feed nut bracket is not adjustable; only front nut is adjustable).
4. Loosen the two nut locking screws.
5. Turn nut slightly to tighten it against opposing nut.
6. Tighten the two nut locking screws.
7. Using cross feed crank, move table to middle position.
8. Set up a dial indicator to check cross feed backlash. Gently move cross feed crank back and forth while watching dial indicator. Backlash should be between 0.003 inch and 0.005 inch.
9. If necessary, repeat the above steps.
10. Install pleated way cover.

11.5.2 Longitudinal backlash adjustment

Refer to Figure 14:

Only one of the longitudinal lead screw nuts can be adjusted; the other nut is fixed. The left hand nut is typically adjustable. This can be determined by looking at nut from underside of table.

1. Loosen the two nut locking screws.
2. Turn the nut slightly to tighten it against the opposing nut.
3. Tighten the two nut locking screws.
4. Using one of the longitudinal table cranks, move table to middle position.
5. Set up a dial indicator to check longitudinal backlash. Gently move crank back and forth while watching dial indicator. The backlash should be between 0.003 inch and 0.005 inch.
6. If necessary, repeat the above steps to set backlash.

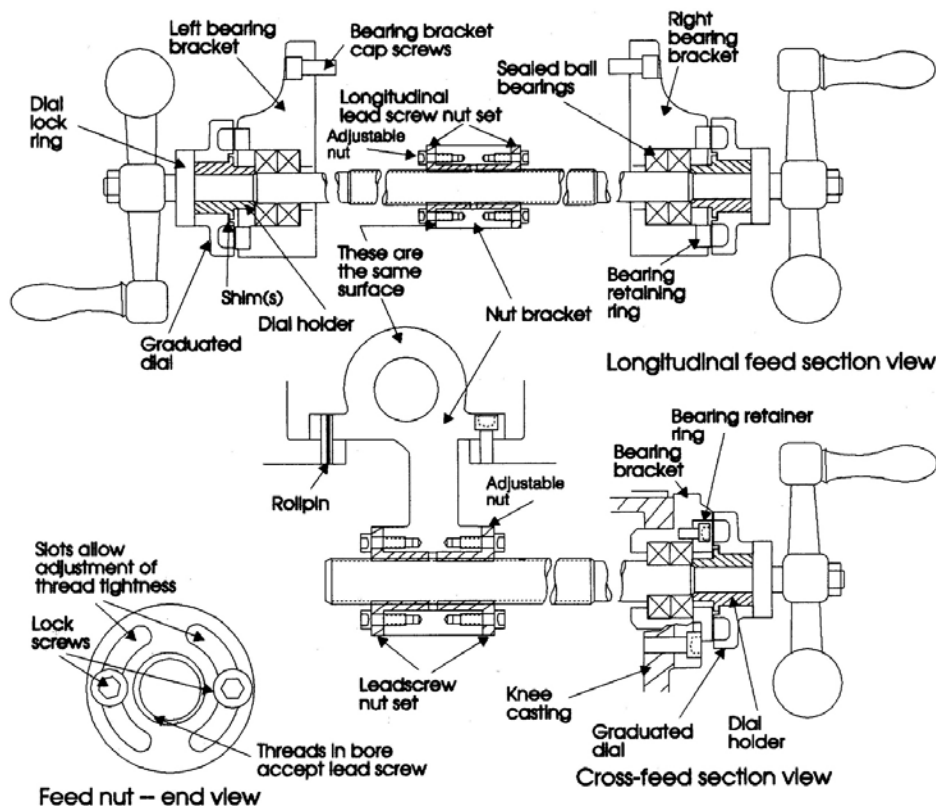

Table Lead Screw Components

Figure 14: Lead screw backlash adjustment

12.0 Speed charts for JVM-836

The charts below are also found on the mill head of the respective models.

SINGLE PHASE ONLY

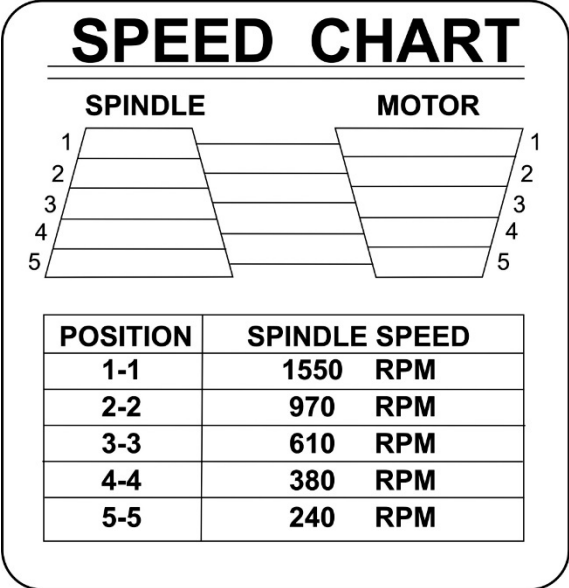

Figure 15

3-PHASE ONLY

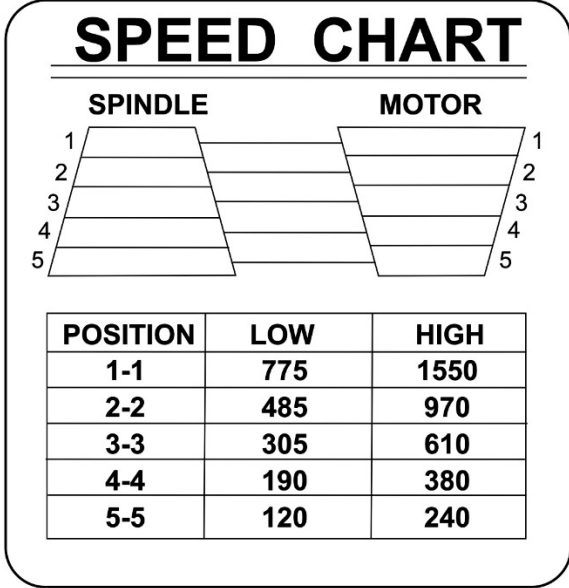
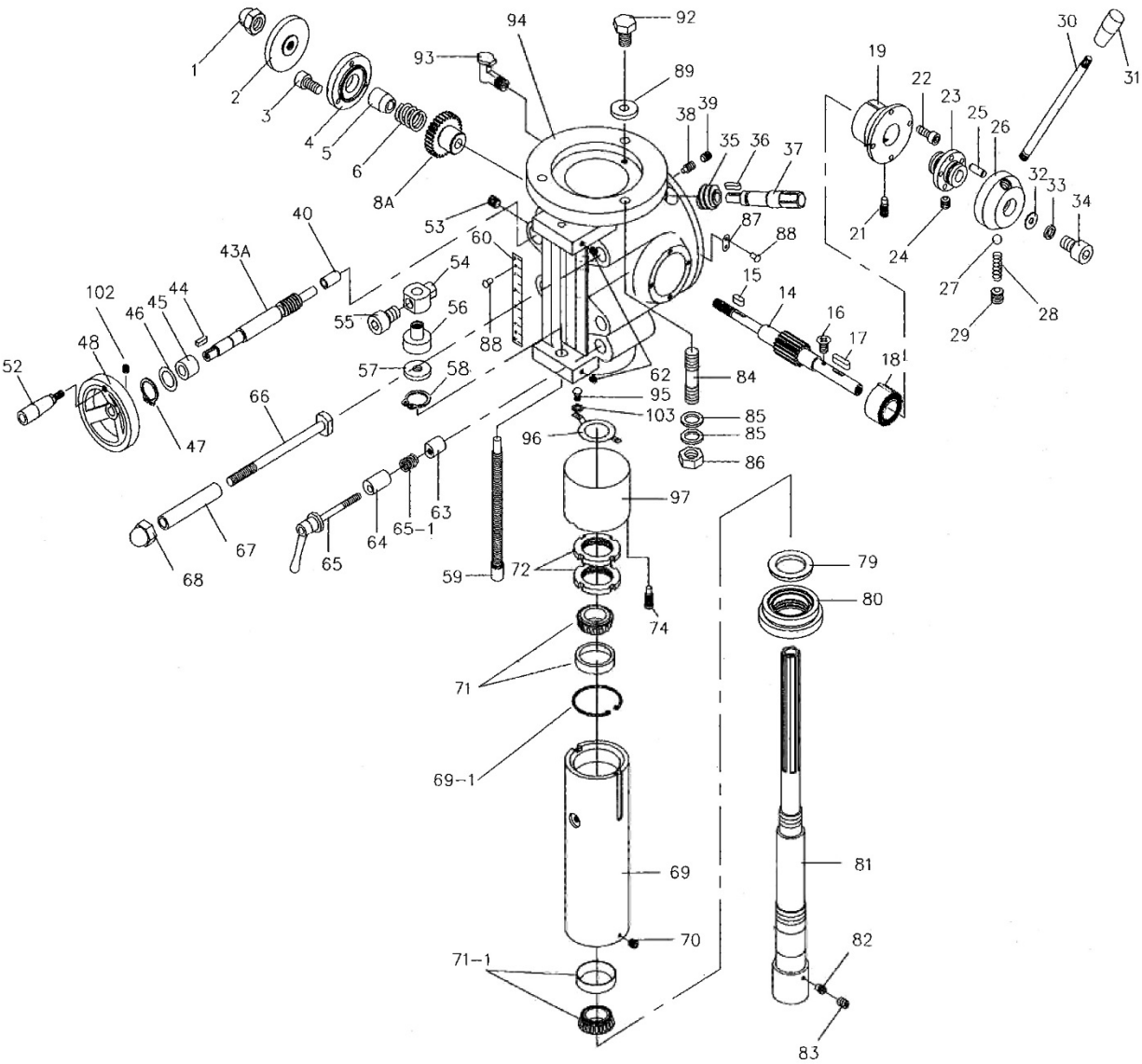

Figure 16

13.0 Replacement Parts

Replacement parts are listed on the following pages. To order parts or reach our service department, call 1-800-274-6848 Monday through Friday, 8:00 a.m. to 5:00 p.m. CST. Having the Model Number and Serial Number of your machine available when you call will allow us to serve you quickly and accurately.

13.1.1 JVM-836 Head Assembly – Exploded View



13.1.3 JVM-836 Head Assembly – Parts List

Index No	Part No	Description	Size	Qty
1	JVM836-01	Castle Nut	M12	1
2	JVM836-02	Lock Nut		1
3	TS-1523041	Hex Socket Cap Screw	M6x12	3
4	JVM836-04	Cover		1
5	JVM836-05	Taper Sleeve		1
6	JVM836-06	Spring		1
7	JVM836-07	Transmission Sleeve (s/n 307XXXX and lower)		1
8	JVM836-08	Worm Gear (s/n XXX0049 and lower)		1
	JVM836-08T	Worm Gear (s/n 0040050 and higher)		1
8A	JVM836-08TN	Worm Gear (s/n 307XXXX and higher)		1
9	JVM836-09	Spring Washer (s/n 307XXXX and lower)	M4	3
10	JVM836-10	Cross Round Head Screw (s/n 307XXXX and lower)	M4x16	3
14	JVM836-14	Shaft (s/n XXX0049 and lower)		1
	JVM836-14T	Shaft (s/n 0040050 and higher)		1
15	JVM836-15	Key (s/n XXX0049 and lower)	5x5x20 mm	1
	JVM836-15T	Key (s/n 0040050 and higher)	5x5x12 mm	1
16	JVM836-16	Cross Flat Head Screw	M5x6	1
17	JVM836-17	Whitney Key		1
18	JVM836-18	Volume Spring (s/n XXX0049 and lower)		1
	JVM836-18T	Volume Spring (s/n 0040050 and higher)		1
19	JVM836-19	Spring Bracket		1
21	JVM836-21	Full Dog Point Set Screw	M8x35	1
22	TS-1514021	Hex Socket Cap Screw	M6x15	4
23	JVM836-23	Transmission Sleeve		1
24	TS-1523031	Set Screw	M6x6	1
25	JVM836-25	Round Pin		1
26	JVM836-26	Handle Base (s/n XXXX0049 and lower)		1
	JVM836-26T	Handle Base (s/n 0040050 and higher)		1
	JVM836-26TA	Handle Assembly (includes # 26,30,31)		1
27	SB-6MM	Steel Ball	Ø6	1
28	JVM836-28	Spring		1
29	TS-1524011	Set Screw	M8x8	1
30	JVM836-30	Rocket Rod (s/n XXX0049 and lower)		1
	JVM836-30T	Rocket Rod (s/n 0040050 and higher)		1
31	JVM836-31	Knob (s/n XXX0049 and lower)		1
	JVM836-31T	Knob (s/n 0040050 and higher)		1
32	JVM836-32	Flat Washer	M8	1
33	JVM836-33	Spring Washer	M8	1
34	JVM836-34	Hex Socket Cap Screw	M8x16	1
35	JVM836-35	Worm (s/n XXX0049 and lower)		1
	JVM836-35T	Worm (s/n 0040050 and higher)		1
36	JVM836-36	Whitney Key	4x4x16 mm	1
37	JVM836-37	Worm Shaft		1
38	JVM836-38	Full Dog Point Set Screw	M5x6	1
39	TS-1522011	Set Screw	M5x6	1
40	JVM836-40	Bushing (s/n XXX0049 and lower)		1
	JVM836-40T	Bushing (s/n 0040050 and higher)		1
41	JVM836-41	Spring Pin (s/n 307XXXX and lower)	Ø3x14 mm	1
42	JVM836-42	Worm (s/n XXX0049 and lower)		1
	JVM836-42T	Worm (s/n 307XXXX and lower)		1
43	JVM836-43	Shaft (s/n XXX0049 and lower)		1
	JVM836-43T	Shaft (s/n 0040050 and higher)		1
	JVM836-43TN	Shaft (s/n 307XXXX and higher)		1
44	JVM836-44	Flat Key	4x4x12 mm	1
45	JVM836-45	Bushing (s/n XXX0049 and lower)		1
	JVM836-45T	Bushing (s/n 0040050 and higher)		1
46	JVM836-46	Spacer		1
47	JVM836-47	C-Retaining Ring		1
48	JVM836-48G	Wheel		1

Index No	Part No	Description	Size	Qty
52	JVM836-52	Hand Grip		1
53	TS-1523041	Set Screw	M6x10	1
54	JVM836-54	Locating Block		1
55	JVM836-55	Hex Socket Cap Screw	3/8-24UNF	1
56	JVM836-56	Graduated Ring		1
57	JVM836-57	Graduated Tight Nut		1
58	JVM836-58	C-Retaining Ring		1
59	JVM836-59	Screw		1
60	JVM836-60	Graduated Scale		1
62	TS-1523041	Set Screw	M6x12	2
63	JVM836-63	Tight Collar		1
64	JVM836-64	Tight Collar		1
65	JVM836-65G	Flexible Handle		1
66	JVM836-66	T-Head Bolt		4
67	JVM836-67	Sleeve Pipe		4
68	JVM836-68	Castle Nut		4
69	JVM836-69	Rack Sleeve (s/n xxx0049 and lower)		1
	JVM836-69T	Rack Sleeve (s/n 0040050 to 0050103)		1
	JVM836-69TN	Rack Sleeve (s/n: 0050104 and higher)		1
69-1	JVM836-69T-1	C-Clip	R62	1
70	JVM836-70	Cone point Set Screw	M5x5	1
71	JVM836-71	Taper Roller Bearing	30206	1
71-1	JVM836-71-1	Taper Roller Bearing	32008	1
72	JVM836-72	Nut (s/n xxx0049 and lower)		1
	JVM836-72T	Nut (s/n 0040050 and higher)		2
	JVM836-72TA	Nut Assembly (includes # 72,83,98)		1
79	JVM836-79	Protection Ring		1
80	JVM836-80	Protection Cover (s/n xxx0049 and lower)		1
	JVM836-80T	Protection Cover (s/n 0040050 and higher)		1
81	JVM836-81	Spindle Shaft		1
82	JVM836-82	Full Dog Point Set Screw	M6x6	1
83	TS-1522011	Set Screw	M5x6	1
84	JVM836-84	Stud	M12x50	3
85	JVM836-85	Spring Washer	M12	3
86	TS-1540081	Hex Nut	M12	3
87	JVM836-87	Limit Plate		1
88	JVM836-88	Rivet	Ø2	5
89	JVM836-89	Stop Block (s/n xxx0049 and lower)		1
	JVM836-89T	Stop Block (s/n 0040050 and higher)		1
90	TS-1523041	Set Screw	M6x12	1
91	TS-1540041	Hex. Nut	M6	1
92	TS-41490011	Hex. Screw	M8x12	1
93	JVM836-93	Oil Cup	1/16"PS	1
94	JVM836-94	Head Body (s/n xxx0049 and lower)		1
	JVM836-94T	Head Body (s/n 0040050 and higher)		1
	JVM836-94TG	Head Body		1
95	JVM836-95	Cross Round Cap Screw	M5x6	2
96	JVM836-96	Plate		1
97	JVM836-97	Cover		1
102	JVM836-102	Set Screw	M5x6	1

13.2.1 JVM-836 Upper Head Assembly – Exploded View

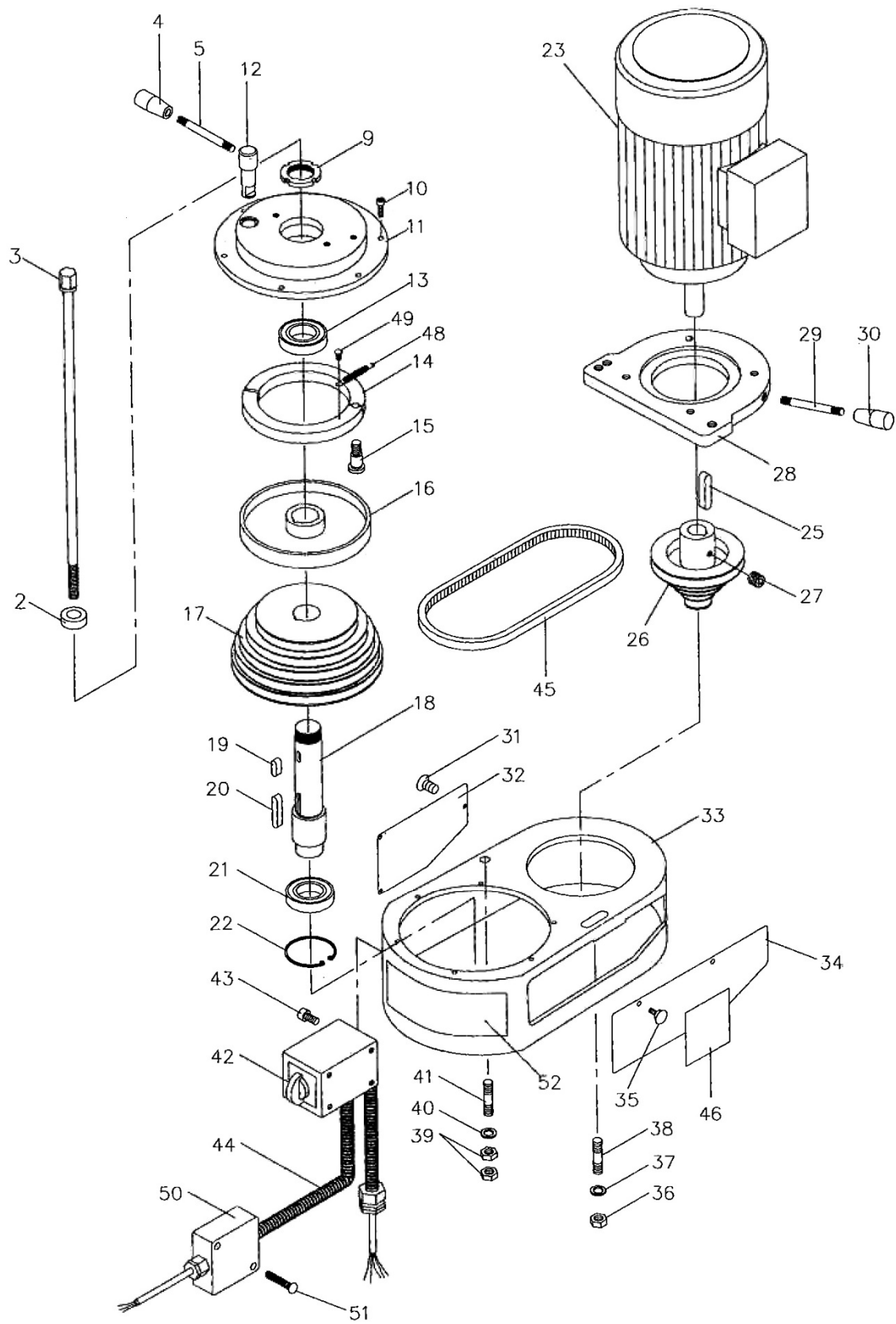

13.2.2 JVM-836 Upper Head Assembly – Parts List

Index No	Part No	Description	Size	Qty
2	VM-G22-1	Spacer		1
3	VM-G22	Draw Bar		1
4	VM-M3-1	Knob (s/n XXX0049 and lower)		1
	VM-M3-1T	Knob (s/n 0040050 and higher)		1
5	VM-M3-3	Brake Handle (s/n XXX0049 and lower)		1
	VM-M3-3T	Brake Handle (s/n 0040050 and higher)		1
9	VM-M11-1	Nut		1
10	TS-1514021	Hex Head Socket Screw	M6x16	6
11	VM-M4	Fixed Cover (s/n XXX0049 and lower)		1
	VM-M4T	Fixed Cover (s/n 0040050 and higher)		1
	VM-M4TG	Fixed Cover		1
12	VM-M3-5	Brake Rod (s/n XXX0049 and lower)		1
	VM-M3-5T	Brake Rod (s/n 0040050 and higher)		1
13	BB-6007ZZ	Ball Bearing	6007zz	1
14	VM-M2	Brake (s/n XXX0049 and lower)		1
	VM-M2T	Brake (s/n 0040050 and higher)		1
	VM-M2TA	Brake Assembly (includes #14,15,48,49)		1
15	VM-M1	Screw (s/n XXX0049 and lower)		1
	VM-M1T	Screw (s/n 0040050 and higher)		1
16	VM-M6	Brake Disc		1
17	VM-M8	Pulley		1
18	VM-M11	Splined Shaft		1
19	VM-M7	Whitney Key	6x6x16 mm	1
20	VM-M9	Whitney Key	6X6X32 mm	1
21	BB-6007ZZ	Ball Bearing	6007zz	1
22	VM-M5	C-Retaining Ring	Ø62 mm	1
23	VM-M25C	Motor (s/n XXX0049 and lower)	(1-1/2HP 1 Ph)	1
	VM-M25C-3Ph	Motor (s/n XXX0049 and lower)	(1-1/2HP 3 Ph)	1
	VM-M25	Motor (s/n 0040050 to 2110610)	(1-1/2HP 1 Ph)	1
	VM-M25-3Ph	Motor (s/n 0040050 to 2110610)	(1-1/2HP 3 Ph)	1
	VM-M25N	Motor (s/n 2120611 and higher)	(1-1/2HP 1 Ph)	1
	VM-M25N-3Ph	Motor (s/n 2120611 and higher)	(1-1/2HP 3 Ph)	1
	VM-M25CS	Centrifugal Switch (not shown)		1
	VM-M25RC	Running Capacitor (not shown)	25µF 350VAC	1
	VM-M25SC	Starting Capacitor (not shown)	350MFD 350VAC	1
24	VM-M21	Hex Head Screw	M10x25	4
25	VM-M25-1	Flat Key	8x7x36 mm	1
26	VM-M19	Pulley (s/n 2110610 and lower)		1
	VM-M19N	Pulley (s/n 2120611 and higher)		1
27	TS-1524011	Set Screw	M8x8	1
28	VM-M20	Motor Cover (s/n XXX0049 and lower)		1
	VM-M20T	Motor Cover (s/n 0040050 to 2110610)		1
	VM-M20TN	Motor Cover (s/n 2120611 and higher)		1
29	VM-M3	Rod (s/n XXX0049 and lower)		1
	VM-M3T	Rod (s/n 0040050 and higher)		1
30	VM-M3-1	Knob (s/n XXX0049 and lower)		1
	VM-M3-1T	Knob (s/n 0040050 and higher)		1
31	JVM836-31B	Cross Flat Head Screw	M6x6	3
32	VM-M12-2G	Cover		1
33	VM-M12G	Pulley Housing		1
34	VM-M12-1G	Cover		1
35	VM-DM85	Plum Knob (s/n 0040049 and lower)		2
	JVM836-31B	Cross Flat Screw (s/n 0040050 and higher)	M6x6	2
36	TS-1540081	Hex Nut	M12	1
37	TS-1550081	Flat Washer	M12	1
38	VM-M23-1	Stud	M12x50	1
39	TS-1540081	Hex Nut	M12	2
40	TS-1550081	Flat Washer	M12	1
41	VM-M23-1	Stud	M12x50	1

Index No	Part No	Description	Size	Qty
42	JVM836-42B	Switch Assembly (1Ph)		1
	JVM836-42-3Ph	Switch Assembly (3Ph)		1
43	JVM836-43B	Hex Socket Cap Screw	M6x8	4
44	JVM836-44B	Switch Cord (4C, 1Ph)		1
	JVM836-44-3Ph	Switch Cord (7C, 3Ph)		1
45	VB-A29	Belt	A29	1
46	VM-M26-1PHG	Spindle Speed Chart (1 Phase)		1
	VM-M26-3PHG	Spindle Speed Chart (3 Phase)		1
48	VM-M2-1	Spring		2
49	VM-M2-2	Cross Round Cap Screw		2
50	JVM836-U50	Plastic Electrical Box		1
51	JVM836-U51	Cross Round Cap Screw	M5x40L	2
52	JVM836-N01G	JET Label		1

13.3.1 JVM-836 Leadscrew Assembly – Exploded View

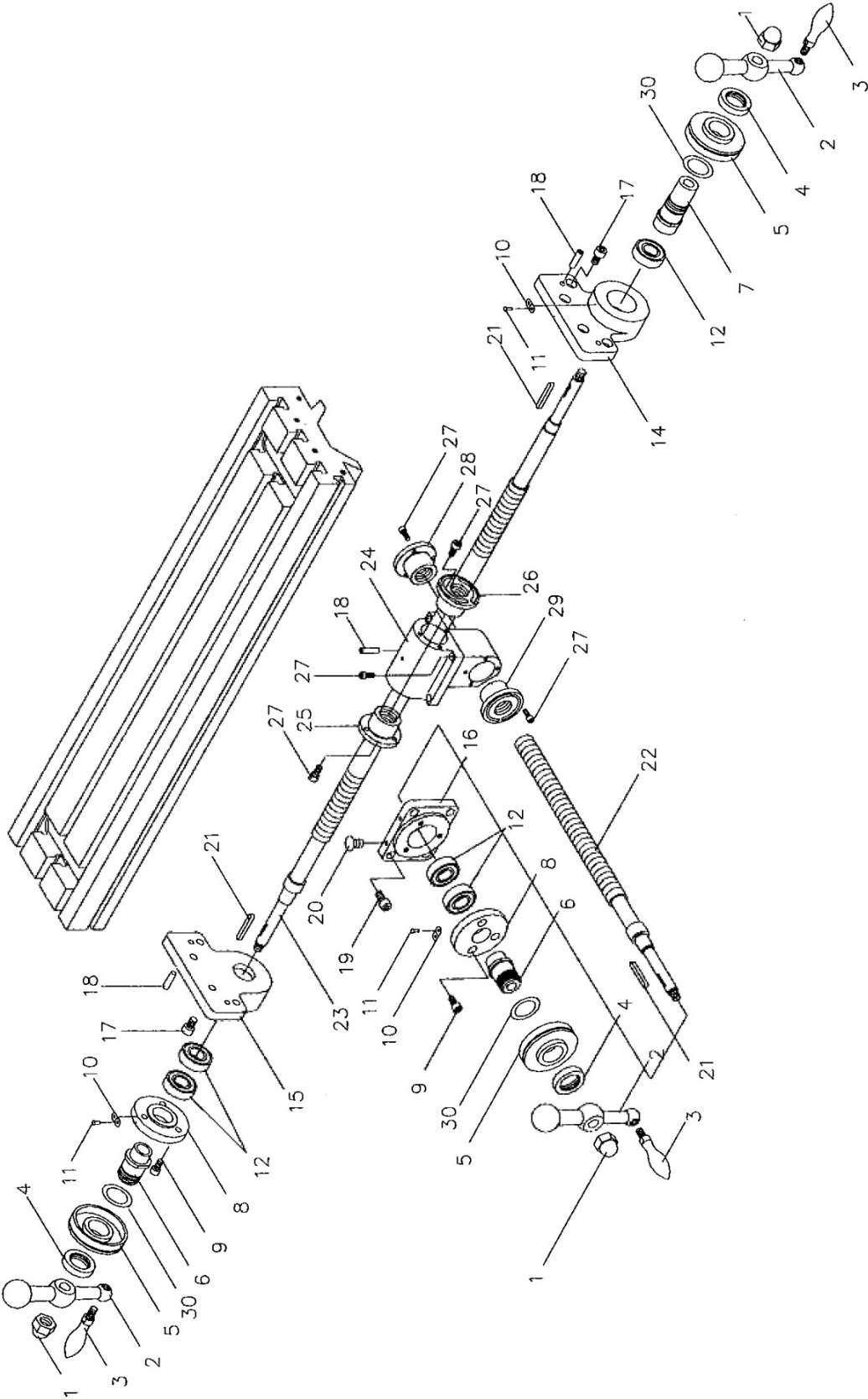

13.3.2 JVM-836 Leadscrew Assembly – Parts List

Index No	Part No	Description	Size	Qty
1	VM-I1	Castle Nut	M12	3
2	VM-I2G	Handle		3
3	VM-I2-1G	Ball Handle		3
4	VM-I3	Knurled Nut (s/n XXX0049 and lower)		3
	VM-I3T	Knurled Nut (s/n 0040050 and higher)		3
5	VM-I5	Dial (s/n XXX0049 and lower)		3
	VM-I5T	Dial (s/n 0040050 and higher)		3
6	VM-I24	Dial Holder (s/n XXX0049 and lower)		2
	VM-I24TG	Dial Holder (s/n 0040050 and higher)		2
	VM-I24TA	Dial Holder Assembly (includes #4,5,6,30)		1
7	VM-I6	Dial Holder (s/n XXX0049 and lower)		1
	VM-I6TG	Dial Holder (s/n 0040050 and higher)		1
	VM-I6TA	Dial Holder Assembly (includes #4,5,7,30)		1
8	VM-I8	Bearing Retaining Cover		2
9	TS-1515011	Hex Socket Screw	M8x16	6
10	VM-M26	Limit Plate		3
11	VM-M26-1	Rivet	Ø12 mm	6
12	BB-6204	Ball Bearing	6204	5
14	VM-I14	Bearing Bracket		1
15	VM-I18	Bearing Bracket		1
16	VM-J11	Bearing Block		1
17	VM-I13	Hex Socket Screw	M10x16	8
18	VM-I12	Taper Pin	Ø8x130 mm	6
19	TS-1515021	Hex Socket Screw	M8x20	4
20	JVM836-20B	Flat Screw	M6x6	2
21	VM-I4	Whitney Key	3x3x28 mm	3
22	VM-J16	Lead Screw (s/n 2010471 and lower)		1
	VM-J16T	Lead Screw (s/n 2020472 and higher)		1
23	VM-I15	Lead Screw (s/n 2010471 and lower)		1
	VM-I15T	Lead Screw (s/n 2020472 and higher)		1
24	VM-J28	Feed Nut Bracket		1
25	VM-J26-1	Feed Screw Nut (s/n 2010471 and lower)		1
	VM-J26-1T	Feed Screw Nut (s/n 2020472 and higher)		1
26	VM-J26	Feed Screw Nut (s/n 2010471 and lower)		1
	VM-J26T	Feed Screw Nut (s/n 2020472 and higher)		1
27	TS-1514021	Hex Socket Screw	M6x16	14
28	VM-J25-1	Feed Screw Nut (s/n 2010471 and lower)		1
	VM-J25-1T	Feed Screw Nut (s/n 2020472 and higher)		1
29	VM-J25	Feed Screw Nut (s/n 2010471 and lower)		1
	VM-J25T	Feed Screw Nut (s/n 2020472 and higher)		1
30	JVM836-T30	Spacer		3
	JVM836-I2A	Washer with Keyway (not shown)		3

13.4.1 JVM-836 Base Assembly – Exploded View

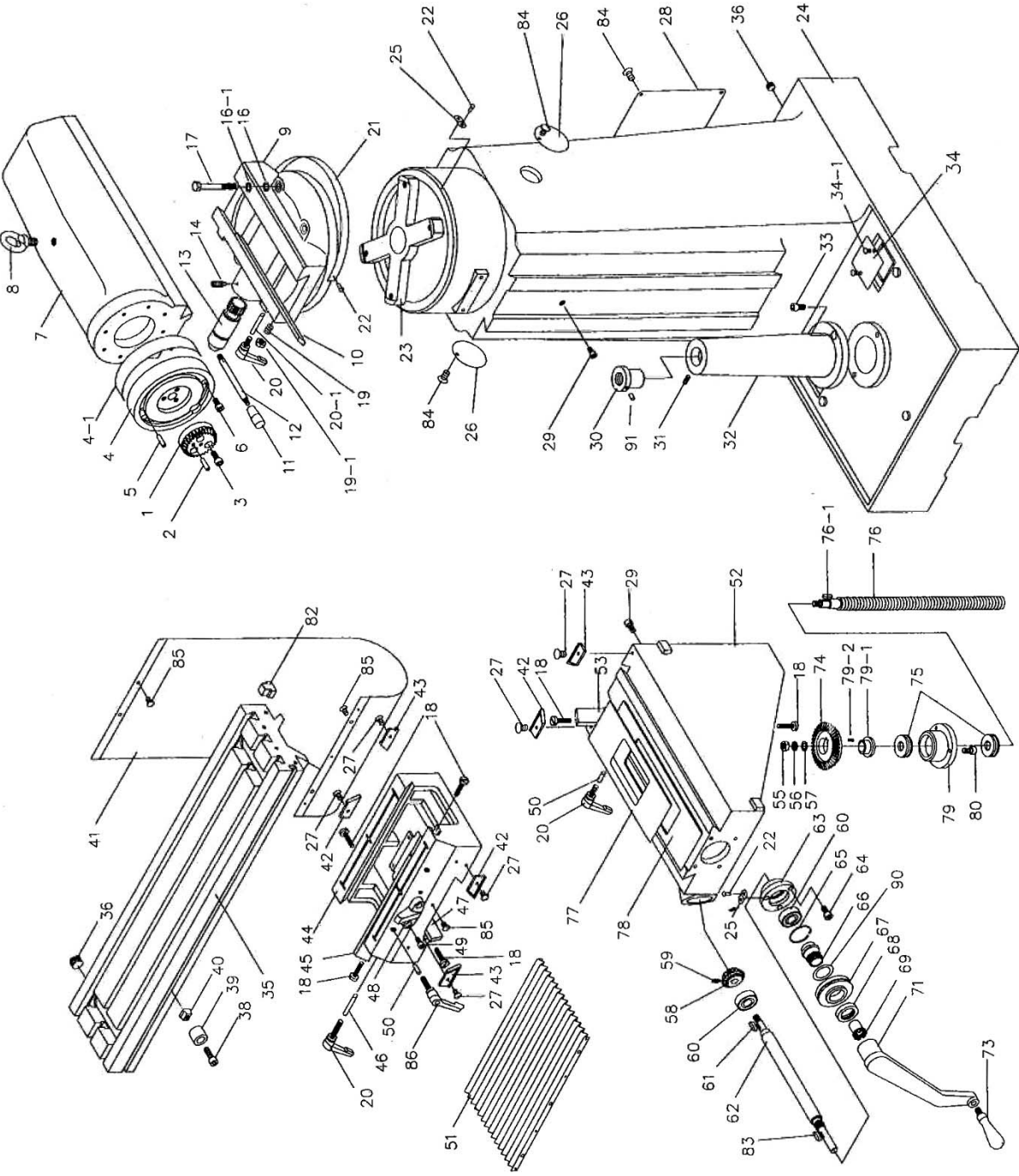

13.4.2 JVM-836 Base Assembly – Parts List

Note: Some index numbers in this parts list have two part numbers. If your milling machine has the serial number 0040050 and higher, use the part number ending with a “T.” If your milling machine has the serial number xxx0049 and lower, use the part number without the letter “T.”

Index No	Part No	Description	Size	Qty
1	VM-L11	Worm Gear (s/n XXX0049 and lower)		1
	VM-L11T	Worm Gear (s/n 0040050 and higher)		1
2	VM-L13	Taper Pin	Ø8x150	1
3	TS-1505031	Hex Socket Screw	M10x25	3
4	VM-L10G	Graduated Dial		1
4-1	VM-L10-1	Graduated Dial Plate		1
5	VM-L9	Taper Pin	Ø8x130	2
6	TS-1515011	Hex Socket Screw	M8x16	8
7	VM-L15G	Ram		1
8	JVM836-08B	Eye Bolt	M16	1
9	VM-L6G	Turret		1
10	VM-L5	Turret Gib		1
11	VM-L1-1	Knob (s/n XXX0049 and lower)		1
	VM-L1-1T	Knob (s/n 0040050 and higher)		1
12	VM-L1	Handle (s/n XXX0049 and lower)		1
	VM-L1T	Handle (s/n 0040050 and higher)		1
13	VM-L3	Pinion Shaft (s/n XXX0049 and lower)		1
	VM-L3T	Pinion Shaft (s/n 0040050 and higher)		1
	VM-L3TA	Pinion Shaft Assembly (includes #11,12,13)		1
14	VM-L2	Full Dog Point Set Screw	M6x12	1
16	TS-1550081	Flat Washer	M12	4
17	VM-K12	Stud (serial # 0040063 & lower)	M12x105	4
17	VM-K12N	Stud (serial # 0040064 & higher)	M12x115	4
18	JVM836-18B	Adjustable Screw		6
19	TS-1523021	Set Screw	M6x10	2
19-1	TS-1540041	Hex Nut	M6	2
20	VM-L4	Lock Handle	M10x40	5
20-1	VM-L4-1	Shoe		2
21	VM-L7	Graduated Scale		1
22	VM-L7-1	Rivet	Ø2 mm	7
23	VM-K11	Spider Arm		1
24	VM-K9G	Base		1
25	VM-K17	Limit plate		2
26	VM-K5G	Plate		1
27	JVM836-27B	Cross Flat Screw	M6x6	22
	JVM836-27BT	Cross Round Cap Screw	M5x12	6
28	VM-K13G	Plate		2
29	JVM836-29	Hex Socket Screw	M8x12	2
30	VM-H29	Elevating Nut		1
31	TS-1523051	Set Screw	M6x15	1
32	VM-H30G	Elevation Screw Stand		1
33	VM-H30-1	Hex Socket Screw	M10x30	2
34	VM-K2	Strainer Net		2
34-1	VM-H34-1	Screw	M5x12	4
35	VM-I37	Table		1
36	VM-I40	Oil Plug	3/8"PT	2
38	VM-I33-2	Hex Socket Screw	M8x20	2
39	VM-I33	Stop Ring		2
40	VM-I33-1	T-Nut		2
41	VM-C-100	Rear Way Cover (Plastic)		1
42	VM-H32	Wiper		3
43	VM-H32-1	Wiper		3
44	VM-J36G	Saddle		1
45	VM-I32	Table Gib		1
46	VM-J39-1	Shoe		2

Index No	Part No	Description	Size	Qty
47	VM-J20	Saddle Gib		1
48	VM-J30	Table Stop Bracket		1
49	TS-1515021	Hex Socket Cap Screw	M8x20	2
50	VM-J29-1	Shoe		2
51	VM-C-101	Accordion Way Cover (Plastic)		1
52	VM-H35G	Knee		1
53	VM-H34	Knee Gib		1
55	TS-1540081	Hex Nut	M12	2
56	VM-H19	Spring Washer	M12	2
57	TS-1550081	Flat Washer	M12	2
58	VM-H17	Straight Bevel Gear (s/n XXX0049 and lower)		1
	VM-H17T	Helical Bevel Gear (s/n 0040050 and higher)		1
59	TS-1523031	Set Screw	M6x6	1
60	BB-6204	Ball Bearing	6204	2
61	VM-H6	Whitney Key	5x5x16 mm	3
62	VM-H12	Shaft		1
	VM-H12T	Shaft		1
63	VM-H11	Bearing Block		1
64	TS-1514021	Hex Socket Screw	M6x16	3
65	VM-H7	C-Retaining Ring	Ø47 mm	1
66	VM-H5	Dial Holder		1
	VM-H5T	Dial Holder		1
	VM-H5TA	Dial Holder Assembly (includes #66,67,68,69,71,90)		1
67	VM-H3	Dial		1
	VM-H3T	Dial		1
68	VM-H2	Knurled Nut		1
	VM-H2T	Knurled Nut		1
69	VM-H4	Clutch Insert		1
	VM-H4T	Clutch Insert		1
71	VM-H1	Hand Lever		1
	VM-H1T	Hand Lever		1
73	VM-H1-3G	Hand Grip		1
74	VM-H24	Straight Bevel Gear (s/n XXX0049 and lower)		1
	VM-H24T	Helical Bevel Gear (s/n 0040050 and higher)		1
75	BB-6204	Ball Bearing (s/n 0070226 and lower)	6204	2
	BB-51104	Thrust Bearing (s/n 0080227 and higher)	51104	2
76	VM-H27	Elevating Screw		1
76-1	VM-H27-1	Bushing (s/n 0080227 and higher)		1
77	VM-J37-1	Upper Chip Guard		1
78	VM-J37	Lower Chip Guard		1
79	VM-H25	Bearing Housing (s/n 0070226 and lower)		1
	VM-H25T	Bearing Housing (s/n 0080227 and higher)		1
79-1	VM-H25-1	Adaptor (s/n 0040050 and higher)		1
79-2	JVM836-B79-2	Key (s/n 0040050 and higher)	5x5x10 mm	1
80	TS-1514031	Hex Socket Cap Screw	M6x20	3
81	JVM836-B81	C-Clip	S47	1
82	VM-I39	Rubber T-Nut		6
83	JVM836-B83	Key	3x3x28 mm	1
84	JVM836-B84	Cross Round Cap Screw	M6x10	6
85	JVM836-B85	Cross Round Cap Screw	M6x12	7
86	JVM836-B86	Lock Handle	M10x20	2
89	JVM836-B89	Spacer (s/n 0070226 and lower)		1
90	JVM836-B90	Spacer		1
91	JVM836-B91	Oil Block	1/4"	1

13.5.1 JVM-836 One Shot Lubrication System – Exploded View

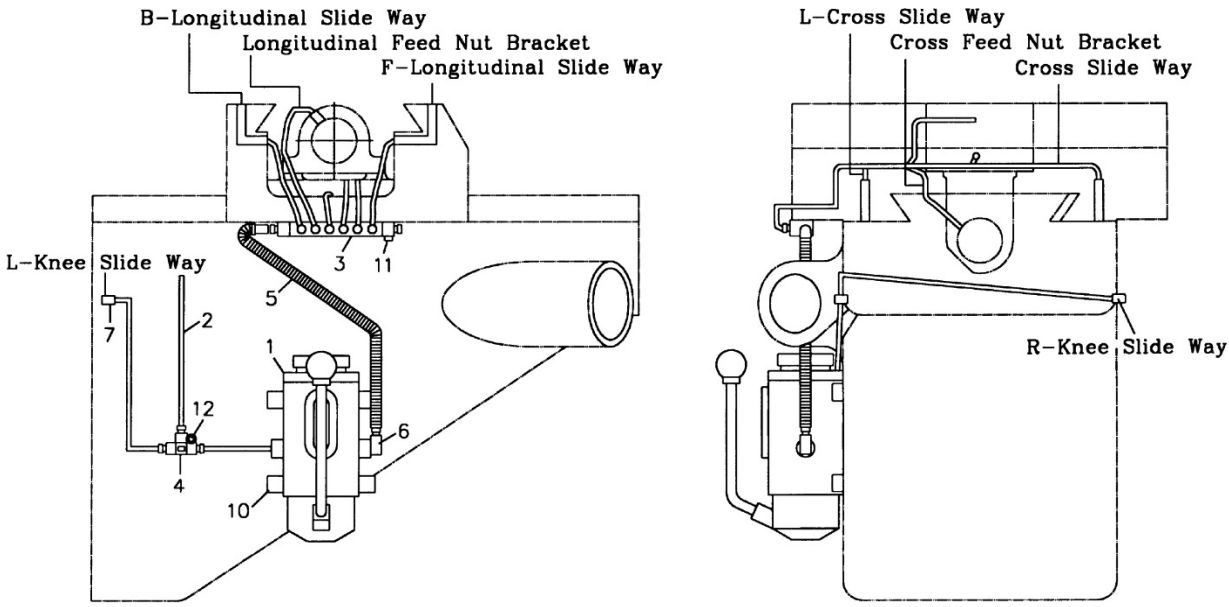

13.5.2 One Shot Lubrication System – Parts List

Index No	Part No	Description	Size	Qty
1	JVM836-HP	Hand Oiling Pump		1
2	JVM836-ALMP	Aluminum Pipe	Ø4	1
3	JVM836-DB	Oil Regulating Distributor		1
4	JVM836-TJ	T-Joint	Ø4	1
5	JVM836-FST	Flexible Steel Tube		1
6	JVM836-CJ	Check Joint	Ø4-1/8PT	2
7	JVM836-EJ	Elbow Joint	Ø4-1/8PT	2
10	TS-1514021	Hex Socket Cap Screw	M6x16	4
11	TS-1503061	Hex Socket Cap Screw	M6x25	2
12	TS-1502061	Hex Socket Cap Screw	M5x25	1

14.0 Electrical Connections for JVM-836

Model No. JVM-836-1
1 Phase Wiring Diagram

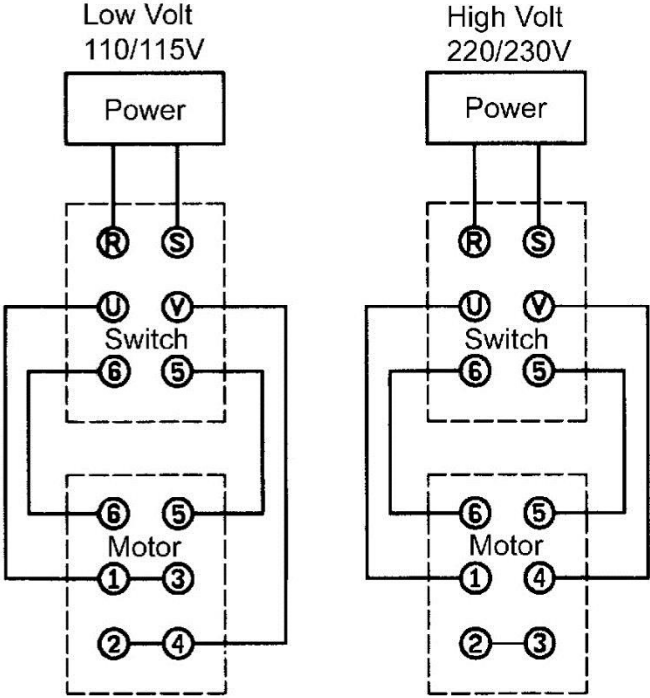

Model No. JVM-836-3
3 Phase 4/8 Poles Wiring Diagram

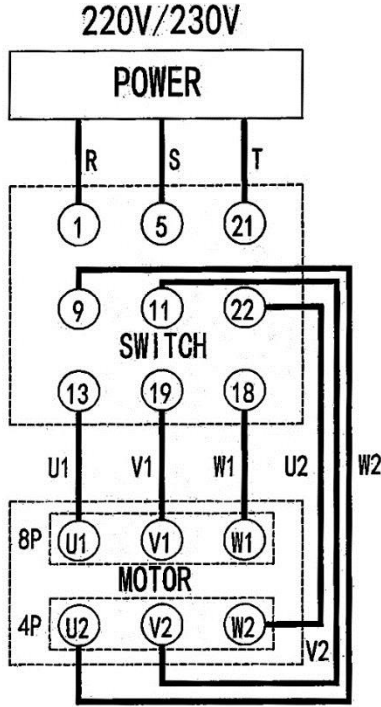

This page intentionally left blank.

This page intentionally left blank.



427 New Sanford Road
LaVergne, Tennessee 37086
Phone: 800-274-6848
www.jettools.com