



2014 CATALOG

MADE IN U.S.A.

A Name You Can Trust



Located in Warren, Michigan, KEO has been producing the best in performance cutting tools since 1941. Our exceptional quality and service has allowed KEO to become a world leader in the cutting tool industry. Over seventy years of commitment to providing the best value is evident in our extensive product offering and our competitive pricing. Whether we are producing our standard catalog offering or quickly turning a “custom” or “special” order for our customers, all tools are produced here in the U.S.A by our highly skilled and prideful associates. In today’s global market you need quality, precision and speed — that’s what you get from KEO an American made product and a name you can trust.

KEO is proud to introduce these new products. Throughout the catalog they are identified by the  logo.

KEO introduces these new offerings to our product line.

- **Combined Drill and Countersinks**
 - Carbide in 82° and 90°.
 - Carbide #3-0 – #5-0 in 60°, 82° and 90°.
 - Carbide Single-End Bell Type Drill.
 - Long Series in 8”.
- **Spotting Drills**
 - High Speed Steel in 82°.
 - Carbide in 82°.
- **Milling Cutters**
 - Metric Woodruff Keyseat Cutters — Shank Type.
- **Tool Sets**
 - Metric Precision 3-Flute Cap Screw Kounterbores Sets.



TABLE OF CONTENTS

Table of Contents Page

Combined Drill and Countersinks.....	3
Double-End Plain Type	4,5
Solid Carbide Plain Type	6
Double-End Radius Type.....	7
Single-End Bell Type	8
Double-End Bell Type	8
Single-End Plain Type Hey.....	9
Single-End Bell Type Hey.....	9
Double-End Plain Type Hey.....	10
Double-End Bell Type Hey.....	10
Jig Bore Type.....	11
Metric Combined Drill and Countersinks.....	12
Double-End Type A	12
Double-End Type B	12
Double-End Type R.....	13
Double-End Long Series.....	14
Double-End Long Series — Solid Carbide	15
Double-End Long Series — Metric Cobalt.....	15

Spotting Drills	17
NC Spotting Drills.....	18, 19
NC Spotting Drills Metric.....	19
NC Spotting Drills Metric Long.....	19
Spotting and Centering Drills	20

Countersinks and Kounterbores.....	21
ZEro Flute Countersinks	22
HSS Single Flute Countersinks.....	23, 24
Single Flute Cobalt Countersinks.....	25
Single Flute Carbide Countersinks	26
3-Flute Center Reamers (HSS).....	27, 28
3-Flute Cobalt Center Reamers	29
3-Flute Carbide Countersinks	30
4-Flute Machine, Straight Shank.....	31
4-Flute Center Reamers	31
6-Flute HSS Countersinks	32
6-Flute Cobalt Countersinks	33
6-Flute Carbide Countersinks	33
Kounterbores, 3-Flute Cap Screw.....	34
Metric Kounterbores, 3-Flute Cap Screw.....	35

Table of Contents Page

Milling Cutters.....	37
Woodruff Keyseat Cutters.....	38
Woodruff Keyseat Cutters Carbide	39
Woodruff Keyseat Cutters Metric	39
Narrow Width Keyseat Cutters.....	40
Small Solid Carbide Keyseat Cutters.....	41
Dovetail Cutters	42
T-Slot Milling Cutters.....	43

Tool Sets	45
Tool Sets.....	46, 47

Technical Information	49
Drilling Time Formula	50
Speeds and Feeds	50, 51, 52
Climb Milling	52

Warning
Cutting tools may shatter when broken. The wearing of eye protection is strongly advised in the vicinity of their use.

Special diameters, flute lengths, long reach, tool coatings etc. are quoted on request. Please call 888.390.2050.



COMBINED DRILL & COUNTERSINKS

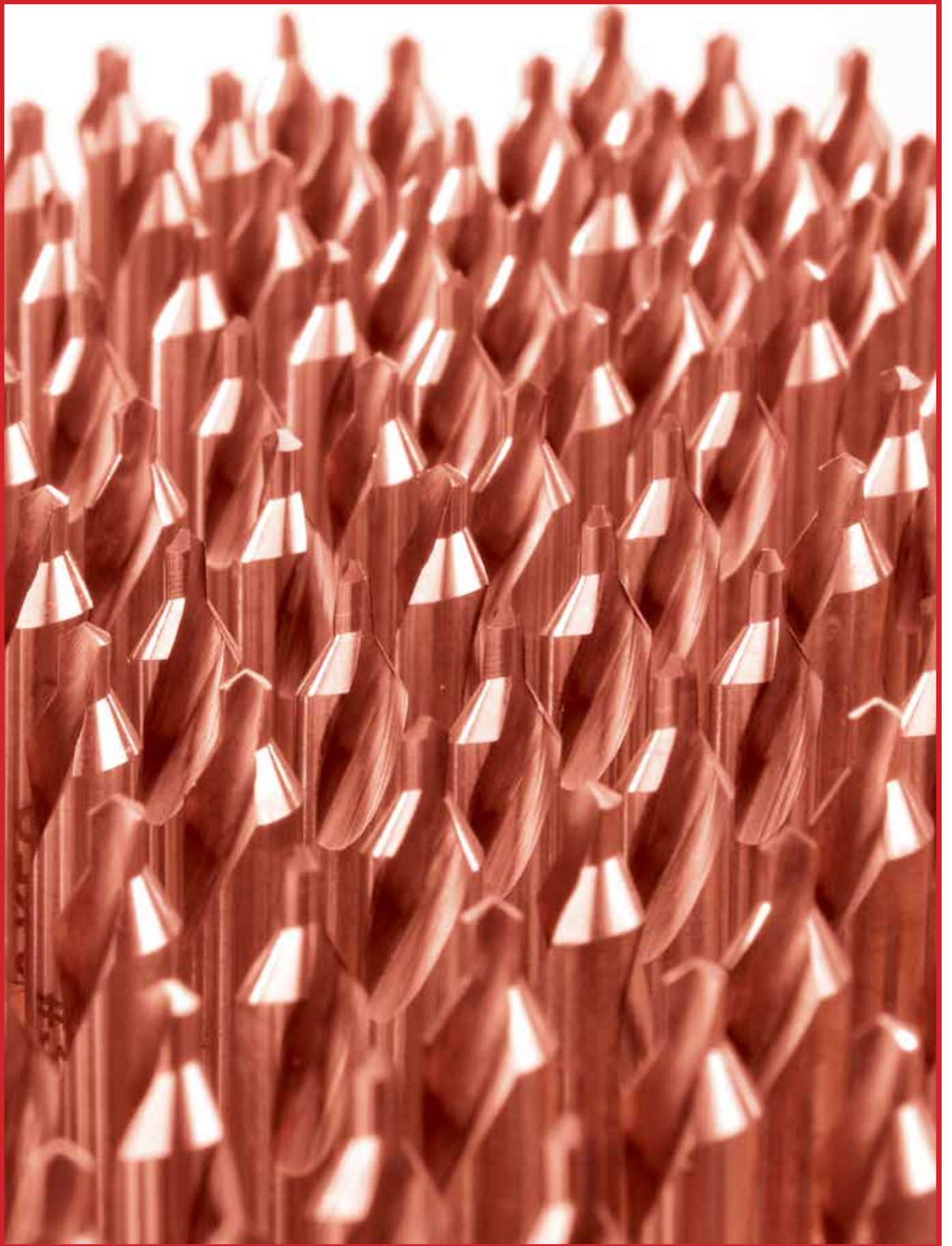

N

ISO 9001:2008 CERTIFIED

E-MAIL: SUPPORT@KEOCUTTERS.COM



COMBINED DRILL & COUNTERSINKS

Combined Drill and Countersinks.....	3
Double-End Plain Type	4,5
Solid Carbide Plain Type	6
Double-End Radius Type.....	7
Single-End Bell Type	8
Double-End Bell Type	8
Single-End Plain Type Hey	9
Single-End Bell Type Hey	9
Double-End Plain Type Hey.....	10
Double-End Bell Type Hey.....	10
Jig Bore Type.....	11
Metric Combined Drill and Countersinks.....	12
Double-End Type A	12
Double-End Type B	12
Double-End Type R	13
Double-End Long Series.....	14
Double-End Long Series — Solid Carbide	15
Double-End Long Series — Metric Cobalt.....	15





Combined Drill & Countersinks — Plain Type

KEO plain type combined drill and countersinks are used for producing center holes in components or workpieces which require machining between centers.

Also available with titanium-nitride coating or in a 5-piece set. For set information see page 46.

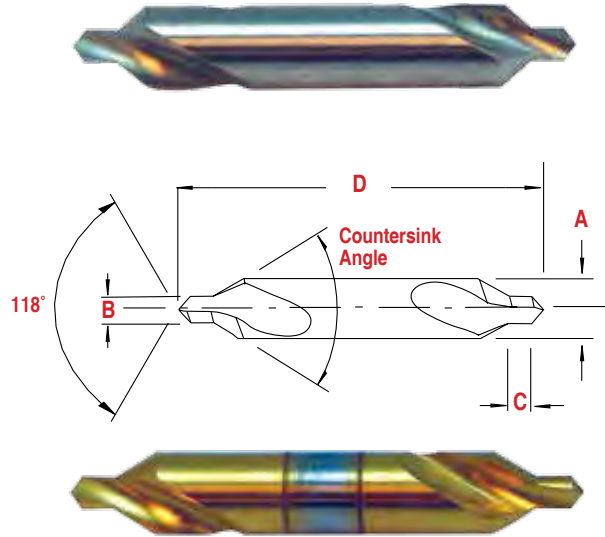

60° Countersink Angle

AIRCRAFT

Size	Product Number					A	B	C	D
	HSS	HSS-TiN	HSS-LH	CO	T15	Body Dia.	Point Dia.	Point Length	OAL
#5-0	10010	10010-TiN	10013	10012	10011	1/8	0.010	0.010	1-1/4
#4-0	10015	10015-TiN	10018	10017	10016	1/8	0.015	0.015	1-1/4
#3-0	10020	10020-TiN	10023	10022	10021	1/8	0.020	0.020	1-1/4
#2-0	10025	10025-TiN	10028	10027	10026	1/8	0.025	0.025	1-1/4
#0	10032	10032-TiN	10035	10034	10033	1/8	1/32	1/32	1-1/4
#1	10100	10100-TiN	10150	10142	10115	1/8	3/64	3/64	1-1/4
#2	10200	10200-TiN	10250	10242	10215	3/16	5/64	5/64	1-7/8
#3	10300	10300-TiN	10350	10342	10315	1/4	7/64	7/64	2
#4	10400	10400-TiN	10450	10442	10415	5/16	1/8	1/8	2-1/8
#4-1/2	14500	14500-TiN	14550	14542	14515	3/8	9/64	9/64	2-1/2
#5	10500	10500-TiN	10550	10542	10515	7/16	3/16	3/16	2-3/4
#6	10600	10600-TiN	10650	10642	10615	1/2	7/32	7/32	3
#7	10700	10700-TiN	10750	10742	10715	5/8	1/4	1/4	3-1/4
#8	10800	10800-TiN	10850	10842	10815	3/4	5/16	5/16	3-1/2
#9	10900	10900-TiN	10950	10942	10915	7/8	11/32	11/32	3-5/8
#10	11000	11000-TiN	11050	11042	11015	1	3/8	3/8	3-3/4

All dimensions in inches.
 Many tools are available with additional coatings.
 Please call for quote.

Tolerance	High	Low
OAL	+1/32	-1/16
Point Ø	+0.003	-0.0
Point Length	Point Ø < 1/32	+0.005 -0.005
	1/32 ≤ Point Ø ≤ 5/64	+0.008 -0.008
	Point > 5/64	+1/64 -1/64
Point Angle	2°	0°
CS Angles	+1°	-1°
Body Ø	+0.0	-0.002



Combined Drill & Countersinks — Plain Type (cont.)

82° Countersink Angle

Size	Product Number		A	B	C	D
	HSS	HSS-TiN	Body Dia.	Point Dia.	Point Length	OAL
#5-0	10038	10038-TiN	1/8	0.01	0.01	1-1/4
#4-0	10039	10039-TiN	1/8	0.015	0.015	1-1/4
#3-0	10040	10040-TiN	1/8	0.02	0.02	1-1/4
#2-0	10029	10029-TiN	1/8	0.025	0.025	1-1/4
#0	10036	10036-TiN	1/8	1/32	1/32	1-1/4
#1	10182	10182-TiN	1/8	3/64	3/64	1-1/4
#2	10282	10282-TiN	3/16	5/64	5/64	1-7/8
#3	10382	10382-TiN	1/4	7/64	7/64	2
#4	10482	10482-TiN	5/16	1/8	1/8	2-1/8
#4-1/2	14582	14582-TiN	3/8	9/64	9/64	2-1/2
#5	10582	10582-TiN	7/16	3/16	3/16	2-3/4
#6	10682	10682-TiN	1/2	7/32	7/32	3
#7	10782	10782-TiN	5/8	1/4	1/4	3-1/4
#8	10882	10882-TiN	3/4	5/16	5/16	3-1/2
#9	10982	10982-TiN	7/8	11/32	11/32	3-5/8
#10	11082	11082-TiN	1	3/8	3/8	3-3/4

A I R C R A F T

Tolerance		High	Low
OAL		+1/32	-1/16
Point Ø		+0.003	-0.0
Point Length	Point Ø < 1/32	+0.005	-0.005
	1/32 ≤ Point Ø ≤ 5/64	+0.008	-0.008
	Point > 5/64	+1/64	-1/64
Point Angle		2°	0°
CS Angles		+1°	-1°
Body Ø		+0.0	-0.002

90° Countersink Angle

Size	Product Number		A	B	C	D
	HSS	HSS-TiN	Body Dia.	Point Dia.	Point Length	OAL
#5-0	10014	10014-TiN	1/8	0.010	0.010	1-1/4
#4-0	10019	10019-TiN	1/8	0.015	0.015	1-1/4
#3-0	10024	10024-TiN	1/8	0.020	0.020	1-1/4
#2-0	10030	10030-TiN	1/8	0.025	0.025	1-1/4
#0	10037	10037-TiN	1/8	1/32	1/32	1-1/4
#1	10190	10190-TiN	1/8	3/64	3/64	1-1/4
#2	10290	10290-TiN	3/16	5/64	5/64	1-7/8
#3	10390	10390-TiN	1/4	7/64	7/64	2
#4	10490	10490-TiN	5/16	1/8	1/8	2-1/8
#4-1/2	14590	14590-TiN	3/8	9/64	9/64	2-1/2
#5	10590	10590-TiN	7/16	3/16	3/16	2-3/4
#6	10690	10690-TiN	1/2	7/32	7/32	3
#7	10790	10790-TiN	5/8	1/4	1/4	3-1/4
#8	10890	10890-TiN	3/4	5/16	5/16	3-1/2
#9	10990	10990-TiN	7/8	11/32	11/32	3-5/8
#10	11090	11090-TiN	1	3/8	3/8	3-3/4

A I R C R A F T

Tolerance		High	Low
OAL		+1/32	-1/16
Point Ø		+0.003	-0.0
Point Length	Point Ø < 1/32	+0.005	-0.005
	1/32 ≤ Point Ø ≤ 5/64	+0.008	-0.008
	Point > 5/64	+1/64	-1/64
Point Angle		2°	0°
CS Angles		+1°	-1°
Body Ø		+0.0	-0.002

All dimensions in inches.

See page 46 for set information.

Many tools are available with additional coatings.

Please call for quote.



Solid Carbide Combined Drill & Countersinks — Plain Type, Straight Flute

KEO plain type solid carbide combined drill and countersinks with straight flutes are used for producing center holes in components or workpieces which require machining between centers.

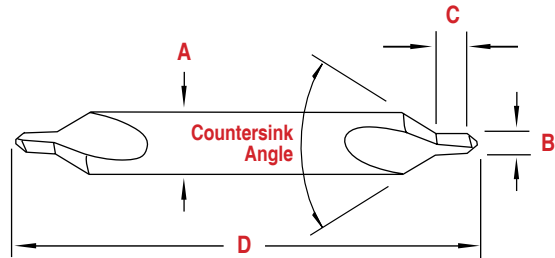

60°, 82° and 90° Countersink Angle

Size	Product Number			Cut	A	B	C	D
	60°	82°	90°		Body Dia.	Point Dia.	Point Length	OAL
#5-0	19010	19011	19012	RH	1/8	0.010	0.010 SE	1-1/2
#4-0	19015	19018	19019	RH	1/8	0.015	0.015 SE	1-1/2
#3-0	19020	19021	19022	RH	1/8	0.020	0.020 SE	1-1/2
#2-0	19025	19028	19029	RH	1/8	0.025	0.025	1-1/2
#0	19032	19038	19039	RH	1/8	1/32	1/32	1-1/2
#1	19105	19108	19109	RH	1/8	3/64	3/64	1-1/2
#2	19205	19208	19209	RH	3/16	5/64	5/64	2
#3	19305	19308	19309	RH	1/4	7/64	7/64	2
#4	19405	19408	19409	RH	5/16	1/8	1/8	2-1/2
#5	19505	19508	19509	RH	7/16	3/16	3/16	2-3/4
#6	19605	19608	19609	RH	1/2	7/32	7/32	3
#7	19705	19708	19709	RH	5/8	1/4	1/4	3-3/4
#8	19805	19808	19809	RH	3/4	5/16	5/16	4

Tolerance		High	Low
OAL		+1/32	-1/16
Point Ø		+0.003	-0.0
Point Length	Point Ø < 1/32	+0.005	-0.005
	1/32 ≤ Point Ø ≤ 5/64	+0.008	-0.008
	Point > 5/64	+1/64	-1/64
Point Angle		2°	0°
CS Angles		+1°	-1°
Body Ø		+0.0	-0.002

All dimensions in inches.

SE denotes single-end combined drill and countersinks,

Many tools are available with additional coatings.

Please call for quote.

Refer to page 15 for Long Series Solid Carbide Combined Drill and Countersinks.





Combined Drill & Countersinks — Radius Type

KEO radius combined drill and countersinks are available in the American standard sizes. These “radius” drills are designed to reduce the bearing surface of the center hole and provide a protected centering seat while reducing the risk of breakage.

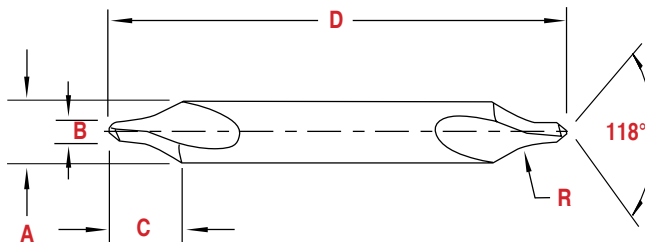

Radius Type

A
I
R
C
R
A
F
T

Size	Product Number		A	B	C	D	R
	HSS	HSS-TiN	Body Dia.	Point Dia.	Point Length	OAL	Radius
#5-0	10050	10050-TiN	1/8	0.010	0.068	1-1/4	1/16
#4-0	10055	10055-TiN	1/8	0.015	0.083	1-1/4	5/64
#3-0	10060	10060-TiN	1/8	0.020	0.097	1-1/4	3/32
#2-0	10065	10065-TiN	1/8	0.025	0.109	1-1/4	7/64
#0	10070	10070-TiN	1/8	1/32	0.118	1-1/4	1/8
#1	10110	10110-TiN	1/8	3/64	0.132	1-1/4	5/32
#2	10210	10210-TiN	3/16	5/64	0.204	1-7/8	7/32
#3	10310	10310-TiN	1/4	7/64	0.275	2	9/32
#4	10410	10410-TiN	5/16	1/8	11/32	2-1/8	3/8
#4-1/2	14510	14510-TiN	3/8	9/64	13/32	2-1/2	7/16
#5	10510	10510-TiN	7/16	3/16	31/64	2-3/4	1/2
#6	10610	10610-TiN	1/2	7/32	35/64	3	9/16
#7	10710	10710-TiN	5/8	1/4	43/64	3-1/4	45/64
#8	10810	10810-TiN	3/4	5/16	13/16	3-1/2	7/8
#9	10910	10910-TiN	7/8	11/32	15/16	3-5/8	1
#10	11010	11010-TiN	1	3/8	1-1/16	3-3/4	1-7/64

All dimensions in inches.

Many tools are available with additional coatings.

Please call for quote.





Combined Drill & Countersinks — Bell Type

KEO bell type combined drill and countersinks are used for producing protected center holes in components or workpieces which require machining between centers as the additional 120° included chamfer eliminates the risk of deforming the countersink seat.

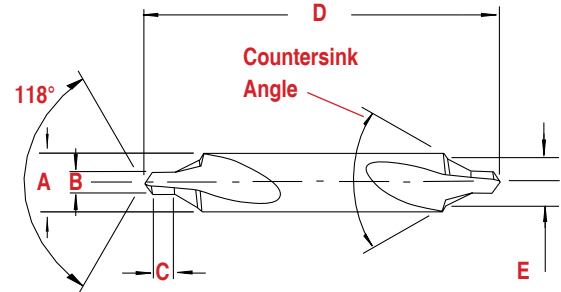

60° Countersink Angle

Size	Product Number					A	B	C	D	E
	HSS	HSS-TiN	HSS-LH	CO	T15	Body Dia.	Point Dia.	Point Length	OAL	Bell Dia.
#11	11100	11100-TiN	11150	11142	11115	1/8	3/64	3/64	1-1/4	0.100
#12	11200	11200-TiN	11250	11242	11215	3/16	1/16	1/16	1-7/8	0.150
#13	11300	11300-TiN	11350	11342	11315	1/4	3/32	3/32	2	0.200
#14	11400	11400-TiN	11450	11442	11415	5/16	7/64	7/64	2-1/8	0.250
#15	11500	11500-TiN	11550	11542	11515	7/16	5/32	5/32	2-3/4	0.350
#16	11600	11600-TiN	11650	11642	11615	1/2	3/16	3/16	3	0.400
#17	11700	11700-TiN	11750	11742	11715	5/8	7/32	7/32	3-1/4	0.500
#18	11800	11800-TiN	11850	11842	11815	3/4	1/4	1/4	3-1/2	0.600
#19	11900	11900-TiN	11950	11942	11915	7/8	5/16	5/16	3-5/8	0.700
#20	12000	12000-TiN	12050	12042	12015	1	3/8	3/8	3-3/4	0.800

All dimensions in inches.

Many tools are available with additional coatings.

Please call for quote.



60° Countersink Angle — Single-End Carbide

Size	Product Number	A	B	C	D	E
		Body Dia.	Point Dia.	Point Length	OAL	Bell Dia.
#11	19110	1/8	3/64	3/64	1-1/4	0.100
#12	19120	3/16	1/16	1/16	1-7/8	0.150
#13	19130	1/4	3/32	3/32	2	0.200
#14	19140	5/16	7/64	7/64	2-1/8	0.250
#15	19150	7/16	5/32	5/32	2-3/4	0.350
#16	19160	1/2	3/16	3/16	3	0.400

Tolerance	High	Low	
OAL	+1/32	-1/16	
Point Ø	+0.003	-0.0	
Point Length	Point Ø < 1/32	+0.005	-0.005
	1/32 ≤ Point Ø ≤ 5/64	+0.008	-0.008
	Point > 5/64	+1/64	-1/64
Point Angle	2°	0°	
Bell Dia.	+0.005	-0.005	
CS Angles	+1°	-1°	
Body Ø	+0.0	-0.002	



Combined Drill & Countersinks — Single-End Plain Type Hey Drill

KEO plain-hey type combined drill and countersinks are designed for use with inserts for producing center holes in components as well as facing the surface of the workpiece, thus combining two machining operations into one.

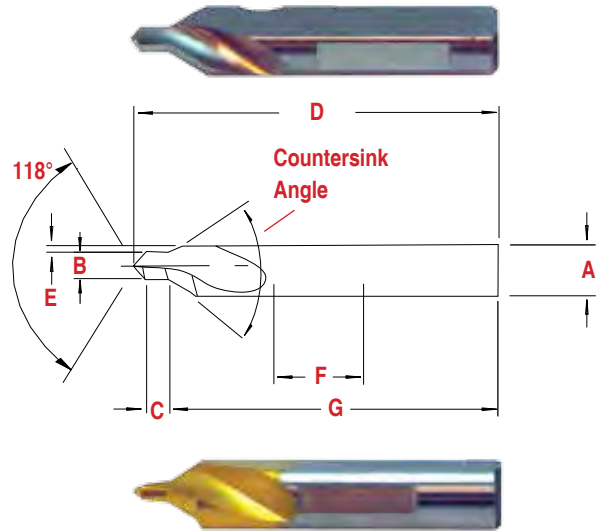

60° Countersink Angle

Size	Product Number		A	B	C	D	E	F	G	Body Flat Offset	Body Flat Depth
	HSS	HSS-TiN	Body Dia.	Point Dia.	Point Length	OAL	Full Flat Depth	Body Flat Length	C'Sink Body Length ± .003		
#1	10121	10121-TiN	1/8	3/64	3/64	3/4	0.020	5/16	1.189	3/8	0.020
#2	10221	10221-TiN	3/16	5/64	5/64	1-3/8	0.043	5/16	1.773	13/32	0.018
#3	10321	10321-TiN	1/4	7/64	7/64	1-1/2	0.055	1/2	1.858	15/32	0.040
#4	10421	10421-TiN	5/16	1/8	1/8	1-5/8	0.075	1/2	1.962	11/16	0.023
#5	10521	10521-TiN	7/16	3/16	3/16	2-1/4	0.086	3/4	2.047	11/16	0.023
#6	10621	10621-TiN	1/2	7/32	7/32	2-1/2	0.086	3/4	2.257	11/16	0.020
#7	10721	10721-TiN	5/8	1/4	1/4	2-3/4	0.105	3/4	2.465	11/16	0.020
#8	10821	10821-TiN	3/4	5/16	5/16	3	0.100	3/4	2.675	11/16	0.020

All dimensions in inches.

Combined Drill & Countersinks — Single-End Bell Type Hey Drill

KEO bell-hey type combined drill and countersinks are designed for use with inserts for producing protective center holes in components as well as facing the surface of the workpiece, thus combining two machining operations into one.

60° Countersink Angle

Size	Product Number		A	B	C	D	E	F	G	Body Flat Offset	Body Flat Depth	Bell Dia.
	HSS	HSS-TiN	Body Dia.	Point Dia.	Point Length	OAL	Full Flat Depth	Body Flat Length	C'Sink Body Length ± .003			
#11	11121	11121-TiN	1/8	3/64	3/64	3/4	0.020	5/16	1.189	3/8	0.020	0.100
#12	11221	11221-TiN	3/16	1/16	1/16	1-3/8	0.038	5/16	1.794	15/32	0.018	0.150
#13	11321	11321-TiN	1/4	3/32	3/32	1-1/2	0.035	5/16	1.878	15/32	0.015	0.200
#14	11421	11421-TiN	5/16	7/64	7/64	1-5/8	0.051	1/2	1.983	11/16	0.023	0.250
#15	11521	11521-TiN	7/16	5/32	5/32	2-1/4	0.066	3/4	2.047	11/16	0.023	0.350
#16	11621	11621-TiN	1/2	3/16	3/16	2-1/2	0.066	3/4	2.257	11/16	0.020	0.400
#17	11721	11721-TiN	5/8	7/32	7/32	2-3/4	0.085	3/4	2.465	11/16	0.020	0.500
#18	11821	11821-TiN	3/4	1/4	1/4	3	0.080	3/4	2.675	11/16	0.020	0.600

All dimensions in inches.

Many tools are available with additional coatings.

Please call for quote.



Combined Drill & Countersinks — Double-End Plain Type Hey Drill

KEO plain-hey type combined drill and countersinks are designed for use with inserts for producing center holes in components as well as facing the surface of the workpiece, thus combining two machining operations into one.

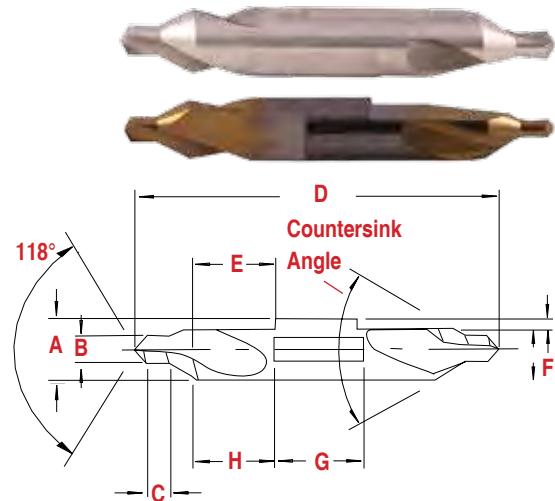

60° Countersink Angle

Size	Product Number		Body Dia.	Point Dia.	Point Length	OAL	End Flat Length	End Flat Depth	Body Flat Length	Body Flat Offset	Body Flat Depth
	HSS	HSS-TiN									
#1	10120	10120-TiN	1/8	3/64	3/64	1-1/4	1/4	0.020	5/16	3/8	0.020
#2	10220	10220-TiN	3/16	5/64	5/64	1-7/8	3/8	0.043	5/16	13/32	0.018
#3	10320	10320-TiN	1/4	7/64	7/64	2	1/2	0.055	1/2	15/32	0.040
#4	10420	10420-TiN	5/16	1/8	1/8	2-1/8	9/16	0.075	1/2	11/16	0.023
#5	10520	10520-TiN	7/16	3/16	3/16	2-3/4	5/8	0.086	3/4	11/16	0.023
#6	10620	10620-TiN	1/2	7/32	7/32	3	5/8	0.086	3/4	11/16	0.020
#7	10720	10720-TiN	5/8	1/4	1/4	3-1/4	5/8	0.105	3/4	11/16	0.020
#8	10820	10820-TiN	3/4	5/16	5/16	3-1/2	5/8	0.100	3/4	11/16	0.020

All dimensions in inches.

Many tools are available with additional coatings.

Please call for quote.

Combined Drill & Countersinks — Double-End Bell Type Hey Drill

KEO bell-hey type combined drill and countersinks are designed for use with inserts for producing protective center holes in components as well as facing the surface of the workpiece, thus combining two machining operations into one.

60° Countersink Angle

Size	Product Number		Body Dia.	Point Dia.	Point Length	OAL	End Flat Length	End Flat Depth	Body Flat Length	Body Flat Offset	Body Flat Depth	Bell Dia.
	HSS	HSS-TiN										
#11	11120	11120-TiN	1/8	3/64	3/64	1-1/4	1/4	0.020	5/16	3/8	0.020	0.100
#12	11220	11220-TiN	3/16	1/16	1/16	1-7/8	3/8	0.038	5/16	15/32	0.018	0.150
#13	11320	11320-TiN	1/4	3/32	3/32	2	7/16	0.035	5/16	15/32	0.015	0.200
#14	11420	11420-TiN	5/16	7/64	7/64	2-1/8	9/16	0.051	1/2	11/16	0.023	0.250
#15	11520	11520-TiN	7/16	5/32	5/32	2-3/4	5/8	0.066	3/4	11/16	0.023	0.350
#16	11620	11620-TiN	1/2	3/16	3/16	3	5/8	0.066	3/4	11/16	0.020	0.400
#17	11720	11720-TiN	5/8	7/32	7/32	3-1/4	5/8	0.085	3/4	11/16	0.020	0.500
#18	11820	11820-TiN	3/4	1/4	1/4	3-1/2	5/8	0.080	3/4	11/16	0.020	0.600

All dimensions in inches.

Many tools are available with additional coatings.

Please call for quote.



Combined Drill & Countersinks — Jig Bore Type

KEO jig bore type combined drill and countersinks are used for producing center holes in components or workpieces which require machining between centers and are manufactured with a locking set screw flat. Also available in a 5-piece set. For set information see page 46.

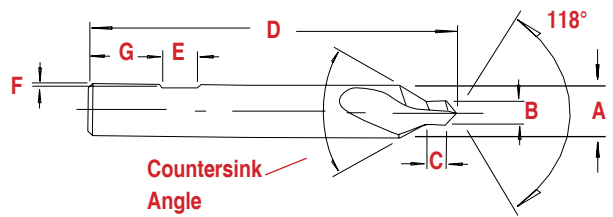

60° Countersink Angle

Size	Product Number	A Body Dia.	B Point Dia.	C Point Length	D OAL	E Body Flat Length	F Body Flat Depth	G Body Flat Offset
3/8 x 1/16	13116	3/8	1/16	1/16	3	9/32	0.050	41/64
3/8 x 3/32	13332	3/8	3/32	3/32	3	9/32	0.050	41/64
3/8 x 1/8	13180	3/8	1/8	1/8	3	9/32	0.050	41/64
3/8 x 5/32	13532	3/8	5/32	5/32	3	9/32	0.050	41/64
3/8 x 3/16	13316	3/8	3/16	3/16	3	9/32	0.050	41/64
1/2 x 1/8	12180	1/2	1/8	1/8	3-1/2	21/64	0.060	23/32
1/2 x 3/16	12316	1/2	3/16	3/16	3-1/2	21/64	0.060	23/32
1/2 x 7/32	12732	1/2	7/32	7/32	3-1/2	21/64	0.060	23/32
1/2 x 1/4	12140	1/2	1/4	1/4	3-1/2	21/64	0.060	23/32
1/2 x 9/32	12932	1/2	9/32	9/32	3-1/2	21/64	0.060	23/32

All dimensions in inches.

Many tools are available with additional coatings.

Please call for quote.





Metric Combined Drill & Countersinks — Type A

KEO metric type A combined drill and countersinks provide the same advantages as KEO standard plain type combined drills and countersinks but are available in standard metric sizes according to DIN333 specifications.

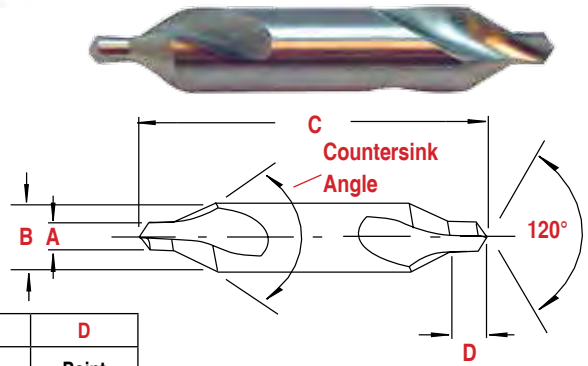

60° Countersink Angle Plain Type

Size	Product Number			A	B	C	D
	HSS	CO	Carbide	Point Dia.	Body Dia.	OAL	Point Length
0.5 x 3.15	16001	16401	16901	0.50	3.15	25.0 SE	0.8
0.8 x 3.15	16002	16402	16902	0.80	3.15	25.0 SE	1.1
1.0 x 3.15	16003	16403	16903	1.00	3.15	31.5	1.3
1.25 x 3.15	16004	16404	16904	1.25	3.15	31.5	1.6
1.6 x 4.0	16040	16440	16940	1.60	4.00	35.5	2.0
2.0 x 5.0	16050	16450	16950	2.00	5.00	40.0	2.5
2.5 x 6.3	16060	16460	16960	2.50	6.30	45.0	3.1
3.15 x 8.0	16080	16480	16980	3.15	8.00	50.0	3.9
4.0 x 10.0	16100	16410	16910	4.00	10.00	56.0	5.0
5.0 x 12.5	16120	16412	16912	5.00	12.50	63.0	6.3
6.3 x 16.0	16160	16416	16916	6.30	16.00	71.0	8.0
8.0 x 20.0	16200	16420	N/A	8.00	20.00	80.0	10.1
10.0 x 25.0	16250	16425	N/A	10.00	25.00	100.0	12.8
12.5 x 31.5	16310	16431	N/A	12.50	31.50	125.0	16.5

SE denotes single-end combined drill and countersinks.
All dimensions in millimeters.

Metric Combined Drill & Countersinks — Type B

KEO metric type B combined drill and countersinks provide the same advantages as KEO standard bell type combined drill and countersinks but are available in standard metric sizes according to DIN333 specifications.

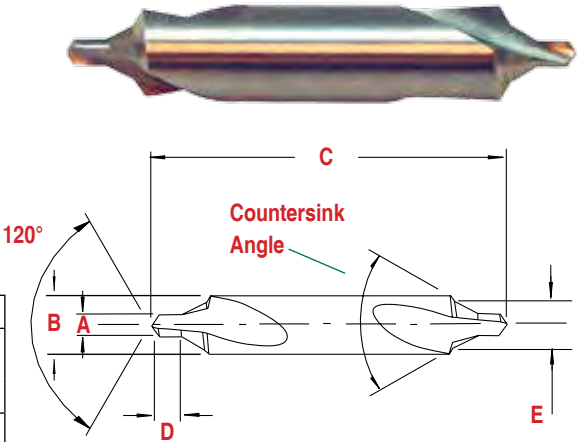

60° Countersink Angle Bell Type

Size	Product Number		A	B	C	D	E
	HSS	CO	Point Dia.	Body Dia.	OAL	Point Length	Bell Dia.
1.0 x 4.0	17040	17440	1.00	4.00	35.5	1.3	2.12
1.25 x 5.0	17050	17450	1.25	5.00	40.0	1.6	2.65
1.6 x 6.3	17060	17460	1.60	6.30	45.0	2	3.35
2.0 x 8.0	17080	17480	2.00	8.00	50.0	2.5	4.25
2.5 x 10.0	17100	17410	2.50	10.00	56.0	3.1	5.30
3.15 x 11.2	17110	17411	3.15	11.20	60.0	3.9	6.70
4.0 x 14.0	17140	17414	4.00	14.00	67.0	5	8.50
5.0 x 18.0	17180	17418	5.00	18.00	75.0	6.3	10.60
6.3 x 20.0	17200	17420	6.30	20.00	80.0	8	13.20
8.0 x 25.0	17250	17425	8.00	25.00	100.0	10.1	17.00
10.0 x 31.5	17310	17431	10.00	31.50	125.0	12.8	21.20

All dimensions in millimeters.
Many tools are available with additional coatings. Please call for quote.



Metric Combined Drill & Countersinks — Type R

KEO metric type R combined drill and countersinks provide the same advantages as KEO standard radius combined drill and countersinks but are available in standard metric sizes according to DIN333 specifications.

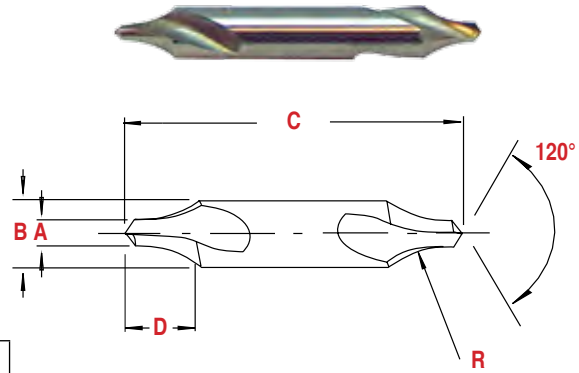

Radius Type

Size	Product Number		A	B	C	D	R
	HSS	CO	Point Dia.	Body Dia.	OAL	Point Length	Radius Max.
0.5 x 3.15	18001	18401	0.50	3.15	25.0 SE	2.12	1.6
0.8 x 3.15	18002	18402	0.80	3.15	25.0 SE	2.65	2.5
1.0 x 3.15	18003	18403	1.00	3.15	31.5	3.0	3.15
1.25 x 3.15	18004	18404	1.25	3.15	31.5	3.35	4.0
1.6 x 4.0	18040	18440	1.60	4.00	35.5	4.25	5.0
2.0 x 5.0	18050	18450	2.00	5.00	40.0	5.3	6.3
2.5 x 6.3	18060	18460	2.50	6.30	45.0	6.7	8.0
3.15 x 8.0	18080	18480	3.15	8.00	50.0	8.5	10.0
4.0 x 10.0	18100	18410	4.00	10.00	56.0	10.6	12.5
5.0 x 12.5	18120	18412	5.00	12.50	63.0	13.2	16.0
6.3 x 16.0	18160	18416	6.30	16.00	71.0	17.0	20.0
8.0 x 20.0	18200	18420	8.00	20.00	80.0	21.2	25.0
10.0 x 25.0	18250	18425	10.00	25.00	100.0	26.5	31.5
12.5 x 31.5	18310	18431	12.50	31.50	125.0	33.5	40.0

SE denotes single-end combined drill and countersinks.

All dimensions in millimeters.

Many tools are available with additional coatings.

Please call for quote.



Combined Drill & Countersinks — Long Series

KEO long series combined drill and countersinks are used for producing center holes in components or workpieces with the extra length allowing access to difficult-to-reach areas.

Long Series 8"

Size	HSS 60°	A	B	C	D
		Body Dia.	Point Dia.	Point Length	OAL
#1 x 8	21080	1/8	3/64	3/64	8
#2 x 8	22080	3/16	5/64	5/64	8
#3 x 8	23080	1/4	7/64	7/64	8
#4 x 8	24080	5/16	1/8	1/8	8
#4-1/2 x 8	24580	3/8	9/64	9/64	8
#5 x 8	25080	7/16	3/16	3/16	8
#6 x 8	26080	1/2	7/32	7/32	8
#7 x 8	27080	5/8	1/4	1/4	8
#8 x 8	28080	3/4	5/16	5/16	8

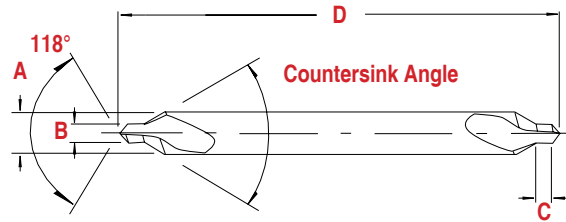

Long Series

Size	Product Number					A Body Dia.	B Point Dia.	C Point Length	D OAL
	Countersink Angle/Coating								
	HSS 60°	HSS-TiN	HSS 82°	HSS 90°	CO 60°				
#1 x 3	21030	21030-TiN	21033	21034	21032	1/8	3/64	3/64	3
#1 x 4	21040	21040-TiN	21043	21044	21042	1/8	3/64	3/64	4
#1 x 5	21050	21050-TiN	21053	21054	21052	1/8	3/64	3/64	5
#1 x 6	21060	21060-TiN	21063	21064	21062	1/8	3/64	3/64	6
#2 x 3	22030	22030-TiN	22033	22034	22032	3/16	5/64	5/64	3
#2 x 4	22040	22040-TiN	22043	22044	22042	3/16	5/64	5/64	4
#2 x 5	22050	22050-TiN	22053	22054	22052	3/16	5/64	5/64	5
#2 x 6	22060	22060-TiN	22063	22064	22062	3/16	5/64	5/64	6
#3 x 3	23030	23030-TiN	23033	23034	23032	1/4	7/64	7/64	3
#3 x 4	23040	23040-TiN	23043	23044	23042	1/4	7/64	7/64	4
#3 x 5	23050	23050-TiN	23053	23054	23052	1/4	7/64	7/64	5
#3 x 6	23060	23060-TiN	23063	23064	23062	1/4	7/64	7/64	6
#4 x 3	24030	24030-TiN	24033	24034	24032	5/16	1/8	1/8	3
#4 x 4	24040	24040-TiN	24043	24044	24042	5/16	1/8	1/8	4
#4 x 5	24050	24050-TiN	24053	24054	24052	5/16	1/8	1/8	5
#4 x 6	24060	24060-TiN	24063	24064	24062	5/16	1/8	1/8	6
#4-1/2 x 4	24540	24540-TiN	24543	24544	24542	3/8	9/64	9/64	4
#4-1/2 x 5	24550	24550-TiN	24553	24554	24552	3/8	9/64	9/64	5
#4-1/2 x 6	24560	24560-TiN	24563	24564	24562	3/8	9/64	9/64	6
#5 x 4	25040	25040-TiN	25043	25044	25042	7/16	3/16	3/16	4
#5 x 5	25050	25050-TiN	25053	25054	25052	7/16	3/16	3/16	5
#5 x 6	25060	25060-TiN	25063	25064	25062	7/16	3/16	3/16	6
#6 x 4	26040	26040-TiN	26043	26044	26042	1/2	7/32	7/32	4
#6 x 5	26050	26050-TiN	26053	26054	26052	1/2	7/32	7/32	5
#6 x 6	26060	26060-TiN	26063	26064	26062	1/2	7/32	7/32	6
#7 x 6	27060	27060-TiN	27063	27064	27062	5/8	1/4	1/4	6
#8 x 6	28060	28060-TiN	28063	28064	28062	3/4	5/16	5/16	6

All dimensions in inches. Many tools are available with additional coatings. Please call for quote.



Combined Drill & Countersinks — Long Series (cont.)

60° Countersink Angle Solid Carbide — Long Series

Size	Product Number	A	B	C	D
		Body Dia.	Point Dia.	Point Length	OAL
#2-0 x 4	29004	1/8	0.025	0.025	4
#2-0 x 6	29006	1/8	0.025	0.025	6
#0 x 4	29014	1/8	1/32	1/32	4
#0 x 6	29016	1/8	1/32	1/32	6
#1 x 4	29104	1/8	3/64	3/64	4
#1 x 6	29106	1/8	3/64	3/64	6
#2 x 4	29204	3/16	5/64	5/64	4
#2 x 6	29206	3/16	5/64	5/64	6
#3 x 4	29304	1/4	7/64	7/64	4
#3 x 6	29306	1/4	7/64	7/64	6
#4 x 4	29404	5/16	1/8	1/8	4
#4 x 6	29406	5/16	1/8	1/8	6
#5 x 4	29504	7/16	3/16	3/16	4
#5 x 6	29506	7/16	3/16	3/16	6
#6 x 4	29604	1/2	7/32	7/32	4
#6 x 6	29606	1/2	7/32	7/32	6
#7 x 6	29706	5/8	1/4	1/4	6
#8 x 6	29806	3/4	5/16	5/16	6

All dimensions in inches.

Metric 60° Countersink Angle Cobalt — Long Series

OAL	Product Number	A	B	C
		Body Dia.	Point Dia.	Point Length
60	15061	3.5	0.75	1
60	15062	4	1	1.3
60	15063	5	1.5	2
80	15081	6	2	2.5
80	15082	8	2.5	3.1
80	15083	8	3	3.9
100	15101	4	1	1.3
100	15102	5	1.5	2
100	15103	6	2	2.5
100	15104	8	2.5	3.1
100	15105	8	3	3.9
100	15106	10	3	3.9
100	15107	10	4	5
100	15108	12	4	5
100	15109	12	5	6.3
120	15121	3.5	0.75	1
120	15122	4	1	1.3
120	15132	5	1.5	2
120	15123	5	1.6	2
120	15124	6	2	2.5
120	15125	8	2.5	3.1
120	15126	8	3	3.9
120	15127	10	3	3.9
120	15128	10	3.15	3.9
120	15129	10	4	5
120	15130	12	4	5
120	15131	14	5	6.3
150	15151	4	1	1.3
150	15152	5	1.5	2
150	15153	6	2	2.5
150	15154	8	2.5	3.1
150	15155	8	3	3.9
150	15156	10	3	3.9
150	15157	10	4	5
150	15158	12	4	5
150	15159	16	6.3	8
200	15201	5	2	2.5
200	15202	6.3	2.5	3.1
200	15203	8	3.15	3.9
200	15204	10	4	5

Point Length C	
Nominal	Tolerance
0 – 1.0 mm	+ 0.3/-0.0
1.1 – 1.4	+ 0.4/-0.0
1.5 – 2.4	+ 0.6/-0.0
2.5 – 3.9	+ 0.7/-0.0
4.0 +	+ 0.9/-0.0

All dimensions in millimeters.





SPOTTING DRILLS

Table of Contents	Page
Spotting Drills	17
NC Spotting Drills.....	18, 19
NC Spotting Drills Metric.....	19
NC Spotting Drills Metric Long.....	19
Spotting and Centering Drills	20





NC Spotting Drills

KEO NC spotting drills are designed with a narrow chisel edge for quick starting and a constant web to allow for resharpening without the need for web thinning.

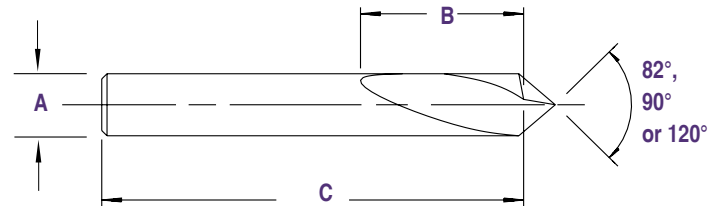

82°, 90° and 120° Point Angle

A										B	C
	82° Point Angle			90° Point Angle			120° Point Angle				
Body Dia.	Product Number		Product Number			Product Number			Flute Length	OAL	
	HSS	CO	HSS	HSS-TiN	CO	HSS	HSS-TiN	CO			
1/4	38142	38143	32140	32140-TiN	32143	33140	33140-TiN	33143	3/4	2-1/2	
1/4	38144	38145	32142	32142-TiN	32145	33142	33142-TiN	33145	3/4	4	
1/4	38146	38147	32144	32144-TiN	32147	33144	33144-TiN	33147	3/4	6	
3/8	38382	38383	32380	32380-TiN	32383	33380	33380-TiN	33383	1-1/8	3-1/8	
3/8	38384	38385	32382	32382-TiN	32385	33382	33382-TiN	33385	1-1/8	5	
3/8	38386	38387	32384	32384-TiN	32387	33384	33384-TiN	33387	1-1/8	7	
1/2	38122	38123	32120	32120-TiN	32123	33120	33120-TiN	33123	1-3/8	3-3/4	
1/2	38124	38125	32122	32122-TiN	32125	33122	33122-TiN	33125	1-3/8	6	
1/2	38126	38127	32124	32124-TiN	32127	33124	33124-TiN	33127	1-3/8	8	
5/8	38582	38583	32580	32580-TiN	32583	33580	33580-TiN	33583	1-5/8	4-3/8	
5/8	38584	38585	32582	32582-TiN	32585	33582	33582-TiN	33585	1-5/8	7	
5/8	38586	38587	32584	32584-TiN	32587	33584	33584-TiN	33587	1-5/8	9	
3/4	38342	38343	32340	32340-TiN	32343	33340	33340-TiN	33343	1-7/8	5	
3/4	38344	38345	32342	32342-TiN	32345	33342	33342-TiN	33345	1-7/8	8	
3/4	38346	38347	32344	32344-TiN	32347	33344	33344-TiN	33347	1-7/8	10	
1	38102	38103	32100	32100-TiN	32103	33100	33100-TiN	33103	2-1/4	6	
1	38104	38105	32102	32102-TiN	32105	33102	33102-TiN	33105	2-1/4	8	
1	38106	38107	32104	32104-TiN	32107	33104	33104-TiN	33107	2-1/4	10	

All dimensions in inches.

Many tools are available with additional coatings.

Please call for quote.



NC Spotting Drills (cont.) 82°, 90° and 120° Point Angles Carbide

A	Product Number					B	C
Body Dia.	82°	90°	90°-TiN	120°	120°-TiN	Flute Length	OAL
1/8	34182	34180	34180-TiN	34181	34181-TiN	3/8	1-1/2
3/16	34185	34187	34187-TiN	34188	34188-TiN	9/16	2
1/4	34145	34140	34140-TiN	34141	34141-TiN	3/4	2-1/2
5/16	34315	34312	34312-TiN	34313	34313-TiN	3/4	2-1/2
3/8	34385	34380	34380-TiN	34381	34381-TiN	3/4	2-1/2
1/2	34125	34120	34120-TiN	34121	34121-TiN	1	3
5/8	34585	34580	34580-TiN	34581	34581-TiN	1	3-1/2
3/4	34345	34340	34340-TiN	34341	34341-TiN	1-1/8	4



All dimensions in inches. All tools are available in all coating types. Many tools are available with additional coatings. Please call for quote.

High Performance Spotting Drills 142° Point Angle Carbide

A	B	C	
Body Dia.	Product Number	Flute Length	OAL
1/8	34184	5/8	1-1/2
3/16	34189	13/16	2
1/4	34144	13/16	2-1/2
5/16	34314	7/8	2-1/2
3/8	34384	7/8	2-1/2
1/2	34124	1-1/8	3
5/8	34584	1-1/8	3-1/2
3/4	34344	1-1/4	4

All dimensions in inches.

Metric NC Spotting Drills — Long 90° and 120° Point Angles Cobalt

A	Product Number		B	C
Body Dia.	90°	120°	Flute Length	OAL
3	35640	35650	10	80
4	35641	35651	12	100
5	35642	35652	15	120
6	35643	35653	20	140
8	35644	35654	25	140
10	35645	35655	25	170
12	35646	35656	30	170
16	35647	35657	35	200
20	35648	35658	40	200

All dimensions in millimeters.

Metric NC Spotting Drills — 90° and 120° Point Angles Cobalt

A	Product Number		B	C
Body Dia.	90°	120°	Flute Length	OAL
2	35600	35620	8	49
3	35601	35621	10	50
4	35602	35622	12	52
5	35603	35623	15	60
6	35604	35624	20	66
8	35605	35625	25	79
10	35606	35626	25	89
12	35607	35627	30	102
14	35608	35628	35	115
16	35609	35629	35	115
18	35610	35630	40	130
20	35611	35631	40	131
25	35612	35632	45	138

All dimensions in millimeters.



Spotting & Centering Drills

KEO spotting and centering drills prevent misalignment frequently caused by using regular drills for centering. These short drills can be chucked close to the point, ensuring accuracy and true starts.

90° Point Angle

A	Product Number			B	C
Body Dia.	RH	RH-TiN	LH	Flute Length	OAL
1/8	30151	30151-TiN	30156	3/8	1-1/4
3/16	30181	30181-TiN	30186	1/2	1-3/8
1/4	30251	30251-TiN	30256	5/8	1-1/2
5/16	30311	30311-TiN	30316	5/8	1-1/2
3/8	30381	30381-TiN	30386	1	2
7/16	30761	30761-TiN	30766	1	2
1/2	30121	30121-TiN	30126	1	2
9/16	30961	30961-TiN	30966	1	2
5/8	30581	30581-TiN	30586	1-1/8	2-1/4
3/4	30341	30341-TiN	30346	1-1/8	2-1/4
7/8	30781	30781-TiN	30786	1-1/4	2-1/2
1	31001	31001-TiN	31006	1-1/4	2-1/2
1-1/4	31141	31141-TiN	31146	2	4
1-1/2	31121	31121-TiN	31126	2-1/2	5
1-3/4	31341	31341-TiN	31346	2-3/4	5-1/2

All dimensions in inches.

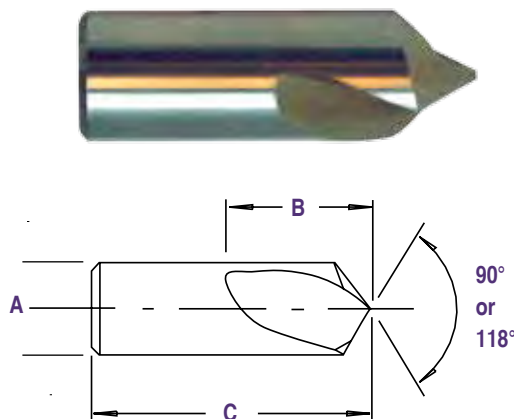

118° Point Angle

A	Product Number			B	C
Body Dia.	RH	RH-TiN	LH	Flute Length	OAL
1/8	30150	30150-TiN	30155	3/8	1-1/4
3/16	30180	30180-TiN	30185	1/2	1-3/8
1/4	30250	30250-TiN	30255	5/8	1-1/2
5/16	30310	30310-TiN	30315	5/8	1-1/2
3/8	30380	30380-TiN	30385	1	2
7/16	30760	30760-TiN	30765	1	2
1/2	30120	30120-TiN	30125	1	2
9/16	30960	30960-TiN	30965	1	2
5/8	30580	30580-TiN	30585	1-1/8	2-1/4
3/4	30340	30340-TiN	30345	1-1/8	2-1/4
7/8	30780	30780-TiN	30785	1-1/4	2-1/2
1	31000	31000-TiN	31005	1-1/4	2-1/2
1-1/4	31140	31140-TiN	31145	2	4
1-1/2	31120	31120-TiN	31125	2-1/2	5
1-3/4	31340	31340-TiN	31345	2-3/4	5-1/2

All dimensions in inches.

Many tools are available with additional coatings. Please call for quote.



COUNTERSINKS & KOUNTERBORES

Table of Contents.....	Page
Countersinks and Kounterbores	21
ZEro Flute Countersinks	22
HSS Single Flute Countersinks.....	23, 24
Single Flute Cobalt Countersinks.....	25
Single Flute Carbide Countersinks	26
3-Flute Center Reamers (HSS).....	27, 28
3-Flute Cobalt Center Reamers	29
3-Flute Carbide Countersinks	30
4-Flute Machine, Straight Shank.....	31
4-Flute Center Reamers	31
6-Flute HSS Countersinks	32
6-Flute Cobalt Countersinks	33
6-Flute Carbide Countersinks	33
Kounterbores, 3-Flute Cap Screw.....	34
Metric Kounterbores, 3-Flute Cap Screw.....	35

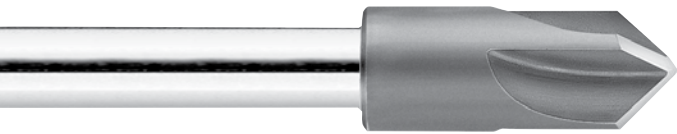



KEO Flute Cobalt Countersink and Deburring Tools

KEO ZERo flute countersink and deburring tools are simple, all-purpose tools made of Cobalt that provide flawless countersinking and deburring. The chatter-free cutting action requires minimal power. The micro-smooth CNC precision ground construction produces clean, smooth cutting without smearing on a variety of materials. The tool especially excels in countersinking or deburring holes in aluminum, plastics and other nonmetallics. For set information see page 47.

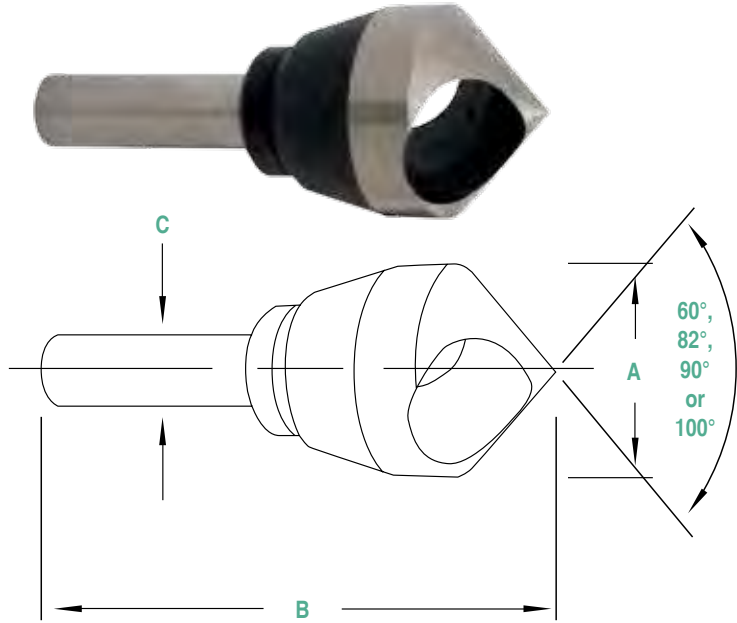

60° Countersink Angle

A Head Dia.	Product Number		Dia. of Cut		B OAL	C Shank Dia.
	Uncoated	TiN	Min.	Max.		
5/16	53500	53500-TiN	7/64	9/32	1-7/8	1/4
3/8	53501	53501-TiN	5/32	11/32	1-7/8	1/4
1/2	53502	53502-TiN	11/64	29/64	2	5/16
5/8	53503	53503-TiN	3/16	37/64	2-1/2	3/8
3/4	53504	53504-TiN	1/4	45/64	2-3/4	3/8
1	53505	53505-TiN	19/64	27/32	3	3/8
1-1/4	53506	53506-TiN	27/64	1-1/32	3-1/2	1/2

All dimensions in inches.
Many tools are available with additional coatings.
Please call for quote.

82° Countersink Angle

A Head Dia.	Product Number		Dia. Of Cut		B OAL	C Shank Dia.
	Uncoated	TiN	Min.	Max.		
5/16	53510	53510-TiN	3/32	9/32	1-5/8	1/4
3/8	53511	53511-TiN	9/64	11/32	1-3/4	1/4
1/2	53512	53512-TiN	5/32	29/64	1-3/4	5/16
5/8	53513	53513-TiN	11/64	37/64	2-1/8	3/8
3/4	53514	53514-TiN	13/64	45/64	2-3/8	3/8
1	53515	53515-TiN	19/64	59/64	2-5/8	3/8
1-1/4	53516	53516-TiN	23/64	1-3/32	3-1/8	1/2

All dimensions in inches.
Many tools are available with additional coatings.
Please call for quote.

90° Countersink Angle

A Head Dia.	Product Number		Dia. Of Cut		B OAL	C Shank Dia.
	Uncoated	TiN	Min.	Max.		
5/16	53520	53520-TiN	3/32	9/32	1-5/8	1/4
3/8	53521	53521-TiN	9/64	11/32	1-3/4	1/4
1/2	53522	53522-TiN	5/32	29/64	1-3/4	5/16
5/8	53523	53523-TiN	11/64	37/64	2-1/8	3/8
3/4	53524	53524-TiN	13/64	45/64	2-3/8	3/8
1	53525	53525-TiN	19/64	59/64	2-5/8	3/8
1-1/4	53526	53526-TiN	23/64	1-3/32	3-1/8	1/2

All dimensions in inches.
Many tools are available with additional coatings.
Please call for quote.

100° Countersink Angle

A Head Dia.	Product Number		Dia. of Cut		B OAL	C Shank Dia.
	Uncoated	TiN	Min.	Max.		
5/16	53530	53530-TiN	3/32	9/32	1-5/8	1/4
3/8	53531	53531-TiN	9/64	11/32	1-3/4	1/4
1/2	53532	53532-TiN	5/32	29/64	1-3/4	5/16
5/8	53533	53533-TiN	11/64	37/64	2-1/8	3/8
3/4	53534	53534-TiN	13/64	45/64	2-3/8	3/8
1	53535	53535-TiN	19/64	59/64	2-5/8	3/8
1-1/4	53536	53536-TiN	23/64	1-1/8	3-1/8	1/2

All dimensions in inches.
Many tools are available with additional coatings.
Please call for quote.



Single Flute Countersinks

KEO single flute countersinks are ideal for chamfering, deburring and countersinking. The large positive rake and single flute construction provide a smooth surface finish on a wide variety of materials. The versatility of this tool should increase productivity on all general purpose applications. Also available in a 5-piece set. For set information see page 46.



60° Countersink Angle

A		B		C	D
Body Dia.	Product Number		OAL	Shank Dia.	Shank Length
	HSS	HSS - TiN			
1/8	53186	53186-TiN	1-1/4	1/8	N/A
3/16	53176	53176-TiN	1-3/8	3/16	N/A
1/4	53146	53146-TiN	1-1/2	1/4	N/A
3/8	53386	53386-TiN	1-3/4	1/4	7/8
1/2	53126	53126-TiN	2	1/4	1
5/8	53586	53586-TiN	2-1/4	3/8	1
3/4	53346	53346-TiN	2-5/8	1/2	1-1/4
1	53106	53106-TiN	2-3/4	1/2	1-1/4
1-1/4	53246	53246-TiN	3	1/2	1-1/4
1-1/2	53226	53226-TiN	3-1/4	3/4	1-1/4
1-3/4	53446	53446-TiN	3-1/2	3/4	1-1/4
2	53206	53206-TiN	3-3/4	3/4	1-1/4

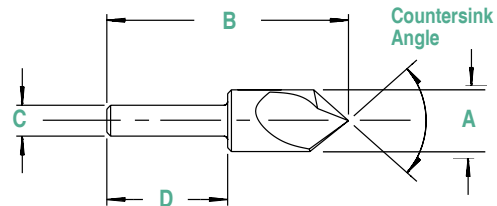

All dimensions in inches.
Many tools are available with additional coatings.
Please call for quote.

82° Countersink Angle

A		B		C	D
Body Dia.	Product Number		OAL	Shank Dia.	Shank Length
	HSS	HSS - TiN			
1/8	53188	53188-TiN	1-1/4	1/8	N/A
3/16	53178	53178-TiN	1-3/8	3/16	N/A
1/4	53148	53148-TiN	1-1/2	1/4	N/A
3/8	53388	53388-TiN	1-3/4	1/4	7/8
1/2	53128	53128-TiN	2	1/4	1
5/8	53588	53588-TiN	2-1/4	3/8	1
3/4	53348	53348-TiN	2-5/8	1/2	1-1/4
1	53108	53108-TiN	2-3/4	1/2	1-1/4
1-1/4	53248	53248-TiN	2-3/4	1/2	1-1/4
1-1/2	53228	53228-TiN	2-7/8	3/4	1-1/4
1-3/4	53448	53448-TiN	3	3/4	1-1/4
2	53208	53208-TiN	3-1/4	3/4	1-1/4

All dimensions in inches.
Many tools are available with additional coatings.
Please call for quote.

90° Countersink Angle

A		B		C	D
Body Dia.	Product Number		OAL	Shank Dia.	Shank Length
	HSS	HSS - TiN			
1/8	53189	53189-TiN	1-1/4	1/8	N/A
3/16	53179	53179-TiN	1-3/8	3/16	N/A
1/4	53149	53149-TiN	1-1/2	1/4	N/A
3/8	53389	53389-TiN	1-3/4	1/4	7/8
1/2	53129	53129-TiN	2	1/4	1
5/8	53589	53589-TiN	2-1/4	3/8	1
3/4	53349	53349-TiN	2-5/8	1/2	1-1/4
1	53109	53109-TiN	2-3/4	1/2	1-1/4
1-1/4	53249	53249-TiN	2-3/4	1/2	1-1/4
1-1/2	53229	53229-TiN	2-7/8	3/4	1-1/4
1-3/4	53449	53449-TiN	3	3/4	1-1/4
2	53209	53209-TiN	3-1/4	3/4	1-1/4

All dimensions in inches.
Many tools are available with additional coatings.
Please call for quote.



Single Flute Countersinks (cont.) 100° Countersink Angle

A	Product Number		B	C	D
Body Dia.	Product Number		OAL	Shank Dia.	Shank Length
	HSS	HSS - TiN			
1/8	53180	53180-TiN	1-1/4	1/8	N/A
3/16	53170	53170-TiN	1-3/8	3/16	N/A
1/4	53140	53140-TiN	1-1/2	1/4	N/A
3/8	53380	53380-TiN	1-3/4	1/4	7/8
1/2	53120	53120-TiN	2	1/4	1
5/8	53580	53580-TiN	2-1/4	3/8	1
3/4	53340	53340-TiN	2-5/8	1/2	1-1/4
1	53100	53100-TiN	2-3/4	1/2	1-1/4
1-1/4	53240	53240-TiN	2-3/4	1/2	1-1/4
1-1/2	53220	53220-TiN	2-7/8	3/4	1-1/4
1-3/4	53440	53440-TiN	3	3/4	1-1/4
2	53200	53200-TiN	3-1/4	3/4	1-1/4

All dimensions in inches.
Many tools are available with additional coatings.
Please call for quote.

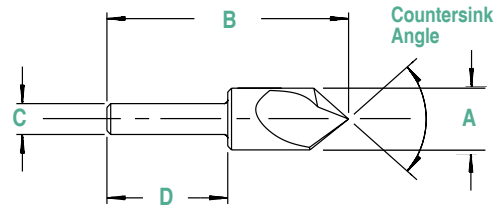

110° Countersink Angle

A	Product Number		B	C	D
Body Dia.	Product Number		OAL	Shank Dia.	Shank Length
	HSS	HSS - TiN			
1/8	53181	53181-TiN	1-1/4	1/8	N/A
3/16	53171	53171-TiN	1-3/8	3/16	N/A
1/4	53141	53141-TiN	1-1/2	1/4	N/A
3/8	53381	53381-TiN	1-3/4	1/4	7/8
1/2	53121	53121-TiN	2	1/4	1
5/8	53581	53581-TiN	2-1/4	3/8	1
3/4	53341	53341-TiN	2-5/8	1/2	1-1/4
1	53101	53101-TiN	2-3/4	1/2	1-1/4
1-1/4	53241	53241-TiN	2-3/4	1/2	1-1/4
1-1/2	53221	53221-TiN	2-7/8	3/4	1-1/4
1-3/4	53441	53441-TiN	3	3/4	1-1/4
2	53201	53201-TiN	3-1/4	3/4	1-1/4

All dimensions in inches.
Many tools are available with additional coatings.
Please call for quote.

120° Countersink Angle

A	Product Number		B	C	D
Body Dia.	Product Number		OAL	Shank Dia.	Shank Length
	HSS	HSS - TiN			
1/8	53182	53182-TiN	1-1/4	1/8	N/A
3/16	53172	53172-TiN	1-3/8	3/16	N/A
1/4	53142	53142-TiN	1-1/2	1/4	N/A
3/8	53382	53382-TiN	1-3/4	1/4	7/8
1/2	53122	53122-TiN	2	1/4	1
5/8	53582	53582-TiN	2-1/4	3/8	1
3/4	53342	53342-TiN	2-5/8	1/2	1-1/4
1	53102	53102-TiN	2-3/4	1/2	1-1/4
1-1/4	53242	53242-TiN	2-3/4	1/2	1-1/4
1-1/2	53222	53222-TiN	2-7/8	3/4	1-1/4
1-3/4	53442	53442-TiN	3	3/4	1-1/4
2	53202	53202-TiN	3-1/4	3/4	1-1/4

All dimensions in inches.
Many tools are available with additional coatings.
Please call for quote.



Single Flute Countersinks (cont.)

60° Countersink Angle Cobalt

Body Dia.	Product Number		OAL	Shank Dia.	Shank Length
	CO	CO-TiN			
1/8	55400	55400-TiN	1-1/4	1/8	N/A
3/16	55401	55401-TiN	1-3/8	3/16	N/A
1/4	55402	55402-TiN	1-1/2	1/4	N/A
3/8	55403	55403-TiN	1-3/4	1/4	7/8
1/2	55404	55404-TiN	2	1/4	1
5/8	55405	55405-TiN	2-1/4	3/8	1
3/4	55406	55406-TiN	2-5/8	1/2	1-1/4
1	55407	55407-TiN	2-3/4	1/2	1-1/4
1-1/4	55408	55408-TiN	3	1/2	1-1/4
1-1/2	55409	55409-TiN	3-1/4	3/4	1-1/4
1-3/4	55410	55410-TiN	3-1/2	3/4	1-1/4
2	55411	55411-TiN	3-3/4	3/4	1-1/4

90° Countersink Angle Cobalt

Body Dia.	Product Number		OAL	Shank Dia.	Shank Length
	CO	CO-TiN			
1/8	55424	55424-TiN	1-1/4	1/8	N/A
3/16	55425	55425-TiN	1-3/8	3/16	N/A
1/4	55426	55426-TiN	1-1/2	1/4	N/A
3/8	55427	55427-TiN	1-3/4	1/4	7/8
1/2	55428	55428-TiN	2	1/4	1
5/8	55429	55429-TiN	2-1/4	3/8	1
3/4	55430	55430-TiN	2-5/8	1/2	1-1/4
1	55431	55431-TiN	2-3/4	1/2	1-1/4
1-1/4	55432	55432-TiN	2-3/4	1/2	1-1/4
1-1/2	55433	55433-TiN	2-7/8	3/4	1-1/4
1-3/4	55434	55434-TiN	3	3/4	1-1/4
2	55435	55435-TiN	3-1/4	3/4	1-1/4

All dimensions in inches.
Many tools are available with additional coatings.
Please call for quote.

110° Countersink Angle Cobalt

Body Dia.	Product Number		OAL	Shank Dia.	Shank Length
	CO	CO-TiN			
1/8	55448	55448-TiN	1-1/4	1/8	N/A
3/16	55449	55449-TiN	1-3/8	3/16	N/A
1/4	55450	55450-TiN	1-1/2	1/4	N/A
3/8	55451	55451-TiN	1-3/4	1/4	7/8
1/2	55452	55452-TiN	2	1/4	1
5/8	55453	55453-TiN	2-1/4	3/8	1
3/4	55454	55454-TiN	2-5/8	1/2	1-1/4
1	55455	55455-TiN	2-3/4	1/2	1-1/4
1-1/4	55456	55456-TiN	2-3/4	1/2	1-1/4
1-1/2	55457	55457-TiN	2-7/8	3/4	1-1/4
1-3/4	55458	55458-TiN	3	3/4	1-1/4
2	55459	55459-TiN	3-1/4	3/4	1-1/4

82° Countersink Angle Cobalt

Body Dia.	Product Number		OAL	Shank Dia.	Shank Length
	CO	CO-TiN			
1/8	55412	55412-TiN	1-1/4	1/8	N/A
3/16	55413	55413-TiN	1-3/8	3/16	N/A
1/4	55414	55414-TiN	1-1/2	1/4	N/A
3/8	55415	55415-TiN	1-3/4	1/4	7/8
1/2	55416	55416-TiN	2	1/4	1
5/8	55417	55417-TiN	2-1/4	3/8	1
3/4	55418	55418-TiN	2-5/8	1/2	1-1/4
1	55419	55419-TiN	2-3/4	1/2	1-1/4
1-1/4	55420	55420-TiN	2-3/4	1/2	1-1/4
1-1/2	55421	55421-TiN	2-7/8	3/4	1-1/4
1-3/4	55422	55422-TiN	3	3/4	1-1/4
2	55423	55423-TiN	3-1/4	3/4	1-1/4

100° Countersink Angle Cobalt

Body Dia.	Product Number		OAL	Shank Dia.	Shank Length
	CO	CO-TiN			
1/8	55436	55436-TiN	1-1/4	1/8	N/A
3/16	55437	55437-TiN	1-3/8	3/16	N/A
1/4	55438	55438-TiN	1-1/2	1/4	N/A
3/8	55439	55439-TiN	1-3/4	1/4	7/8
1/2	55440	55440-TiN	2	1/4	1
5/8	55441	55441-TiN	2-1/4	3/8	1
3/4	55442	55442-TiN	2-5/8	1/2	1-1/4
1	55443	55443-TiN	2-3/4	1/2	1-1/4
1-1/4	55444	55444-TiN	2-3/4	1/2	1-1/4
1-1/2	55445	55445-TiN	2-7/8	3/4	1-1/4
1-3/4	55446	55446-TiN	3	3/4	1-1/4
2	55447	55447-TiN	3-1/4	3/4	1-1/4

120° Countersink Angle Cobalt

Body Dia.	Product Number		OAL	Shank Dia.	Shank Length
	CO	CO-TiN			
1/8	55460	55460-TiN	1-1/4	1/8	N/A
3/16	55461	55461-TiN	1-3/8	3/16	N/A
1/4	55462	55462-TiN	1-1/2	1/4	N/A
3/8	55463	55463-TiN	1-3/4	1/4	7/8
1/2	55464	55464-TiN	2	1/4	1
5/8	55465	55465-TiN	2-1/4	3/8	1
3/4	55466	55466-TiN	2-5/8	1/2	1-1/4
1	55467	55467-TiN	2-3/4	1/2	1-1/4
1-1/4	55468	55468-TiN	2-3/4	1/2	1-1/4
1-1/2	55469	55469-TiN	2-7/8	3/4	1-1/4
1-3/4	55470	55470-TiN	3	3/4	1-1/4
2	55471	55471-TiN	3-1/4	3/4	1-1/4



Single Flute Countersinks (cont.)

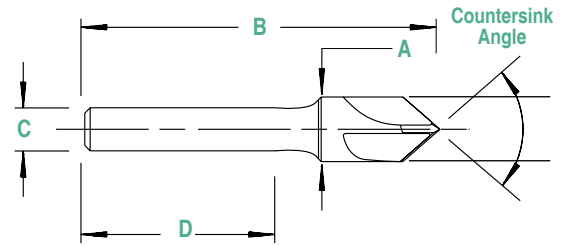

60° Countersink Angles Carbide

Body Dia.	Product Number		OAL	Shank Dia.	Shank Length
	CAR	CAR-TIALN			
1/8	55700	55700-TiALN	1-1/2	1/8	N/A
3/16	55701	55701-TiALN	2	3/16	N/A
1/4	55702	55702-TiALN	2	1/4	N/A
3/8	55703	55703-TiALN	2-7/8	1/4	7/8
1/2	55704	55704-TiALN	2-7/8	1/4	1
5/8	55705	55705-TiALN	3	3/8	1
3/4	55706	55706-TiALN	3	3/8	1-1/4
1	55707	55707-TiALN	3-1/4	1/2	1-1/4
1-1/4	55708	55708-TiALN	3-3/4	3/4	1-1/4

All dimensions in inches.
 Many tools are available with additional coatings. Please call for quote.

82° Countersink Angles Carbide

Body Dia.	Product Number		OAL	Shank Dia.	Shank Length
	CAR	CAR-TIALN			
1/8	55710	55710-TiALN	1-1/2	1/8	N/A
3/16	55711	55711-TiALN	2	3/16	N/A
1/4	55712	55712-TiALN	2	1/4	N/A
3/8	55713	55713-TiALN	2-5/8	1/4	7/8
1/2	55714	55714-TiALN	2-5/8	1/4	1
5/8	55715	55715-TiALN	2-3/4	3/8	1
3/4	55716	55716-TiALN	2-3/4	3/8	1-1/4
1	55717	55717-TiALN	3	1/2	1-1/4
1-1/4	55718	55718-TiALN	3-1/4	3/4	1-1/4

All dimensions in inches.
 Many tools are available with additional coatings. Please call for quote.

90° Countersink Angles Carbide

Body Dia.	Product Number		OAL	Shank Dia.	Shank Length
	CAR	CAR-TIALN			
1/8	55720	55720-TiALN	1-1/2	1/8	N/A
3/16	55721	55721-TiALN	2	3/16	N/A
1/4	55722	55722-TiALN	2	1/4	N/A
3/8	55723	55723-TiALN	2-5/8	1/4	7/8
1/2	55724	55724-TiALN	2-5/8	1/4	1
5/8	55725	55725-TiALN	2-3/4	3/8	1
3/4	55726	55726-TiALN	2-3/4	3/8	1-1/4
1	55727	55727-TiALN	3	1/2	1-1/4
1-1/4	55728	55728-TiALN	3-1/4	3/4	1-1/4

All dimensions in inches.
 Many tools are available with additional coatings. Please call for quote.

100° Countersink Angles Carbide

Body Dia.	Product Number		OAL	Shank Dia.	Shank Length
	CAR	CAR-TIALN			
1/8	55730	55730-TiALN	1-1/2	1/8	N/A
3/16	55731	55731-TiALN	2	3/16	N/A
1/4	55732	55732-TiALN	2	1/4	N/A
3/8	55733	55733-TiALN	2-5/8	1/4	7/8
1/2	55734	55734-TiALN	2-5/8	1/4	1
5/8	55735	55735-TiALN	2-3/4	3/8	1
3/4	55736	55736-TiALN	2-3/4	3/8	1-1/4
1	55737	55737-TiALN	3	1/2	1-1/4
1-1/4	55738	55738-TiALN	3-1/4	3/4	1-1/4

All dimensions in inches.
 Many tools are available with additional coatings. Please call for quote.



3-Flute Center Reamers

KEO 3-flute center reamers are versatile tools designed for countersinking holes for centers or for enlarging existing holes. Also available in a 5-piece set. For set information see page 46.



60° Countersink Angle

A	Product Number		B	C	D
Body Dia.	HSS	HSS-TiN	OAL	Shank Dia.	Shank Length
	1/4	50146			
3/8	50386	50386-TiN	1-3/4	1/4	7/8
1/2	50126	50126-TiN	2	1/4	1
5/8	50586	50586-TiN	2-1/4	3/8	1
3/4	50346	50346-TiN	2-5/8	1/2	1-1/4
1	51006	51006-TiN	2-3/4	1/2	1-1/4
1-1/4	51256	51256-TiN	3	1/2	1-1/4
1-1/2	51506	51506-TiN	3-1/4	3/4	1-1/4
1-3/4	51756	51756-TiN	3-1/2	3/4	1-1/4
2	52306	52306-TiN	3-3/4	3/4	1-1/4

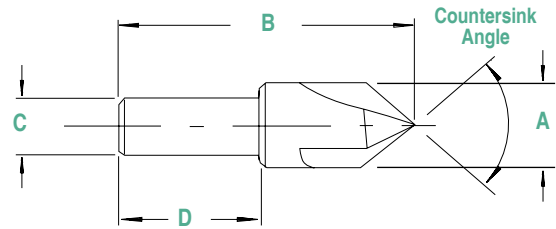

All dimensions in inches.
Many tools are available with additional coatings.
Please call for quote.

82° Countersink Angle

A	Product Number		B	C	D
Body Dia.	HSS	HSS-TiN	OAL	Shank Dia.	Shank Length
	1/4	50148			
3/8	50388	50388-TiN	1-3/4	1/4	7/8
1/2	50128	50128-TiN	2	1/4	1
5/8	50588	50588-TiN	2-1/4	3/8	1
3/4	50348	50348-TiN	2-5/8	1/2	1-1/4
1	51008	51008-TiN	2-3/4	1/2	1-1/4
1-1/4	51258	51258-TiN	2-3/4	1/2	1-1/4
1-1/2	51508	51508-TiN	2-7/8	3/4	1-1/4
1-3/4	51758	51758-TiN	3	3/4	1-1/4
2	52308	52308-TiN	3-1/4	3/4	1-1/4

All dimensions in inches.
Many tools are available with additional coatings.
Please call for quote.

90° Countersink Angle

A	Product Number		B	C	D
Body Dia.	HSS	HSS-TiN	OAL	Shank Dia.	Shank Length
	1/4	50149			
3/8	50389	50389-TiN	1-3/4	1/4	7/8
1/2	50129	50129-TiN	2	1/4	1
5/8	50589	50589-TiN	2-1/4	3/8	1
3/4	50349	50349-TiN	2-5/8	1/2	1-1/4
1	51009	51009-TiN	2-3/4	1/2	1-1/4
1-1/4	51259	51259-TiN	2-3/4	1/2	1-1/4
1-1/2	51509	51509-TiN	2-7/8	3/4	1-1/4
1-3/4	51759	51759-TiN	3	3/4	1-1/4
2	52309	52309-TiN	3-1/4	3/4	1-1/4

All dimensions in inches.
Many tools are available with additional coatings.
Please call for quote.



3-Flute Center Reamers (cont.)

KEO 3-flute center reamers are versatile tools designed for countersinking holes for centers or for enlarging existing holes. Also available in a 5-piece set. For set information see page 46.



100° Countersink Angle

A	Product Number		B	C	D
Body Dia.	HSS	HSS-TiN	OAL	Shank Dia.	Shank Length
	1/4	50140			
3/8	50380	50380-TiN	1-3/4	1/4	7/8
1/2	50120	50120-TiN	2	1/4	1
5/8	50580	50580-TiN	2-1/4	3/8	1
3/4	50340	50340-TiN	2-5/8	1/2	1-1/4
1	51000	51000-TiN	2-3/4	1/2	1-1/4
1-1/4	51250	51250-TiN	2-3/4	1/2	1-1/4
1-1/2	51500	51500-TiN	2-7/8	3/4	1-1/4
1-3/4	51750	51750-TiN	3	3/4	1-1/4
2	52300	52300-TiN	3-1/4	3/4	1-1/4

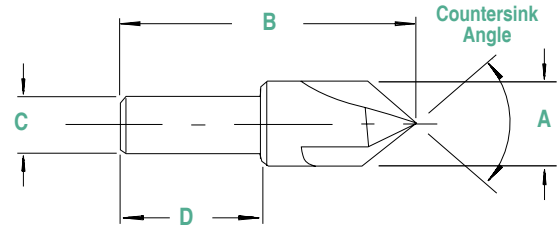

All dimensions in inches.
Many tools are available with additional coatings.
Please call for quote.

110° Countersink Angle

A	Product Number		B	C	D
Body Dia.	HSS	HSS-TiN	OAL	Shank Dia.	Shank Length
	1/4	50141			
3/8	50381	50381-TiN	1-3/4	1/4	7/8
1/2	50121	50121-TiN	2	1/4	1
5/8	50581	50581-TiN	2-1/4	3/8	1
3/4	50341	50341-TiN	2-5/8	1/2	1-1/4
1	51001	51001-TiN	2-3/4	1/2	1-1/4
1-1/4	51251	51251-TiN	2-3/4	1/2	1-1/4
1-1/2	51501	51501-TiN	2-7/8	3/4	1-1/4
1-3/4	51751	51751-TiN	3	3/4	1-1/4
2	52301	52301-TiN	3-1/4	3/4	1-1/4

All dimensions in inches.
Many tools are available with additional coatings.
Please call for quote.

120° Countersink Angle

A	Product Number		B	C	D
Body Dia.	HSS	HSS-TiN	OAL	Shank Dia.	Shank Length
	1/4	50142			
3/8	50382	50382-TiN	1-3/4	1/4	7/8
1/2	50122	50122-TiN	2	1/4	1
5/8	50582	50582-TiN	2-1/4	3/8	1
3/4	50342	50342-TiN	2-5/8	1/2	1-1/4
1	51002	51002-TiN	2-3/4	1/2	1-1/4
1-1/4	51252	51252-TiN	2-3/4	1/2	1-1/4
1-1/2	51502	51502-TiN	2-7/8	3/4	1-1/4
1-3/4	51752	51752-TiN	3	3/4	1-1/4
2	52302	52302-TiN	3-1/4	3/4	1-1/4

All dimensions in inches.
Many tools are available with additional coatings.
Please call for quote.



3-Flute Center Reamers 60° Countersink Angle Cobalt

A	Product Number		B	C	D
Body Dia.	Product Number		OAL	Shank Dia.	Shank Length
	CO	CO-TiN			
1/4	55300	55300-TiN	1-1/2	1/4	N/A
3/8	55301	55301-TiN	1-3/4	1/4	7/8
1/2	55302	55302-TiN	2	1/4	1
5/8	55303	55303-TiN	2-1/4	3/8	1
3/4	55304	55304-TiN	2-5/8	1/2	1-1/4
1	55305	55305-TiN	2-3/4	1/2	1-1/4
1-1/4	55306	55306-TiN	3	1/2	1-1/4
1-1/2	55307	55307-TiN	3-1/4	3/4	1-1/4
1-3/4	55308	55308-TiN	3-1/2	3/4	1-1/4
2	55309	55309-TiN	3-3/4	3/4	1-1/4

82° Countersink Angle Cobalt

A	Product Number		B	C	D
Body Dia.	Product Number		OAL	Shank Dia.	Shank Length
	CO	CO-TiN			
1/4	55310	55310-TiN	1-1/2	1/4	N/A
3/8	55311	55311-TiN	1-3/4	1/4	7/8
1/2	55312	55312-TiN	2	1/4	1
5/8	55313	55313-TiN	2-1/4	3/8	1
3/4	55314	55314-TiN	2-5/8	1/2	1-1/4
1	55315	55315-TiN	2-3/4	1/2	1-1/4
1-1/4	55316	55316-TiN	2-3/4	1/2	1-1/4
1-1/2	55317	55317-TiN	2-7/8	3/4	1-1/4
1-3/4	55318	55318-TiN	3	3/4	1-1/4
2	55319	55319-TiN	3-1/4	3/4	1-1/4

90° Countersink Angle Cobalt

A	Product Number		B	C	D
Body Dia.	Product Number		OAL	Shank Dia.	Shank Length
	CO	CO-TiN			
1/4	55320	55320-TiN	1-1/2	1/4	N/A
3/8	55321	55321-TiN	1-3/4	1/4	7/8
1/2	55322	55322-TiN	2	1/4	1
5/8	55323	55323-TiN	2-1/4	3/8	1
3/4	55324	55324-TiN	2-5/8	1/2	1-1/4
1	55325	55325-TiN	2-3/4	1/2	1-1/4
1-1/4	55326	55326-TiN	2-3/4	1/2	1-1/4
1-1/2	55327	55327-TiN	2-7/8	3/4	1-1/4
1-3/4	55328	55328-TiN	3	3/4	1-1/4
2	55329	55329-TiN	3-1/4	3/4	1-1/4

All dimensions in inches.
Many tools are available
with additional coatings.
Please call for quote.

100° Countersink Angle Cobalt

A	Product Number		B	C	D
Body Dia.	Product Number		OAL	Shank Dia.	Shank Length
	CO	CO-TiN			
1/4	55330	55330-TiN	1-1/2	1/4	N/A
3/8	55331	55331-TiN	1-3/4	1/4	7/8
1/2	55332	55332-TiN	2	1/4	1
5/8	55333	55333-TiN	2-1/4	3/8	1
3/4	55334	55334-TiN	2-5/8	1/2	1-1/4
1	55335	55335-TiN	2-3/4	1/2	1-1/4
1-1/4	55336	55336-TiN	2-3/4	1/2	1-1/4
1-1/2	55337	55337-TiN	2-7/8	3/4	1-1/4
1-3/4	55338	55338-TiN	3	3/4	1-1/4
2	55339	55339-TiN	3-1/4	3/4	1-1/4

110° Countersink Angle Cobalt

A	Product Number		B	C	D
Body Dia.	Product Number		OAL	Shank Dia.	Shank Length
	CO	CO-TiN			
1/4	55340	55340-TiN	1-1/2	1/4	N/A
3/8	55341	55341-TiN	1-3/4	1/4	7/8
1/2	55342	55342-TiN	2	1/4	1
5/8	55343	55343-TiN	2-1/4	3/8	1
3/4	55344	55344-TiN	2-5/8	1/2	1-1/4
1	55345	55345-TiN	2-3/4	1/2	1-1/4
1-1/4	55346	55346-TiN	2-3/4	1/2	1-1/4
1-1/2	55347	55347-TiN	2-7/8	3/4	1-1/4
1-3/4	55348	55348-TiN	3	3/4	1-1/4
2	55349	55349-TiN	3-1/4	3/4	1-1/4

120° Countersink Angle Cobalt

A	Product Number		B	C	D
Body Dia.	Product Number		OAL	Shank Dia.	Shank Length
	CO	CO-TiN			
1/4	55350	55350-TiN	1-1/2	1/4	N/A
3/8	55351	55351-TiN	1-3/4	1/4	7/8
1/2	55352	55352-TiN	2	1/4	1
5/8	55353	55353-TiN	2-1/4	3/8	1
3/4	55354	55354-TiN	2-5/8	1/2	1-1/4
1	55355	55355-TiN	2-3/4	1/2	1-1/4
1-1/4	55356	55356-TiN	2-3/4	1/2	1-1/4
1-1/2	55357	55357-TiN	2-7/8	3/4	1-1/4
1-3/4	55358	55358-TiN	3	3/4	1-1/4
2	55359	55359-TiN	3-1/4	3/4	1-1/4



3-Flute Countersinks

For the carbide family of these tools, the three-flute represents the ideal “general purpose” countersink. They have enough chip clearance in the three-flute design for a variety of ferrous and non-ferrous materials, while providing enough strength with the radial relief design to attack hardened materials up to 40Rc.

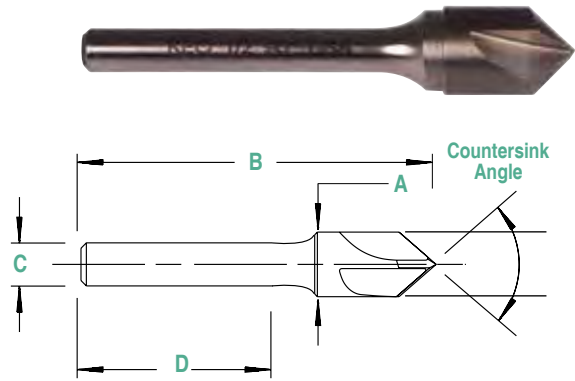

60° Countersink Angles Carbide

A	Product Number		B	C	D
	Body Dia.	Product Number			
1/8	55740	55740-TiALN	1-1/2	1/8	N/A
3/16	55741	55741-TiALN	2	3/16	N/A
1/4	55742	55742-TiALN	2	1/4	N/A
3/8	55743	55743-TiALN	2-7/8	1/4	7/8
1/2	55744	55744-TiALN	2-7/8	1/4	1
5/8	55745	55745-TiALN	3	3/8	1
3/4	55746	55746-TiALN	3	3/8	1-1/4
1	55747	55747-TiALN	3-1/4	1/2	1-1/4
1-1/4	55748	55748-TiALN	3-1/4	3/4	1-1/4

All dimensions in inches.
 Many tools are available with additional coatings.
 Please call for quote.

82° Countersink Angles Carbide

A	Product Number		B	C	D
	Body Dia.	Product Number			
1/8	55750	55750-TiALN	1-1/2	1/8	N/A
3/16	55751	55751-TiALN	2	3/16	N/A
1/4	55752	55752-TiALN	2	1/4	N/A
3/8	55753	55753-TiALN	2-5/8	1/4	7/8
1/2	55754	55754-TiALN	2-5/8	1/4	1
5/8	55755	55755-TiALN	2-3/4	3/8	1
3/4	55756	55756-TiALN	2-3/4	3/8	1-1/4
1	55757	55757-TiALN	3	1/2	1-1/4
1-1/4	55758	55758-TiALN	3-1/4	3/4	1-1/4

All dimensions in inches.
 Many tools are available with additional coatings.
 Please call for quote.

90° Countersink Angles Carbide

A	Product Number		B	C	D
	Body Dia.	Product Number			
1/8	55760	55760-TiALN	1-1/2	1/8	N/A
3/16	55761	55761-TiALN	2	3/16	N/A
1/4	55762	55762-TiALN	2	1/4	N/A
3/8	55763	55763-TiALN	2-5/8	1/4	7/8
1/2	55764	55764-TiALN	2-5/8	1/4	1
5/8	55765	55765-TiALN	2-3/4	3/8	1
3/4	55766	55766-TiALN	2-3/4	3/8	1-1/4
1	55767	55767-TiALN	3	1/2	1-1/4
1-1/4	55768	55768-TiALN	3-1/4	3/4	1-1/4

All dimensions in inches.
 Many tools are available with additional coatings.
 Please call for quote.

100° Countersink Angles Carbide

A	Product Number		B	C	D
	Body Dia.	Product Number			
1/8	55770	55770-TiALN	1-1/2	1/8	N/A
3/16	55771	55771-TiALN	2	3/16	N/A
1/4	55772	55772-TiALN	2	1/4	N/A
3/8	55773	55773-TiALN	2-5/8	1/4	7/8
1/2	55774	55774-TiALN	2-5/8	1/4	1
5/8	55775	55775-TiALN	2-3/4	3/8	1
3/4	55776	55776-TiALN	2-3/4	3/8	1-1/4
1	55777	55777-TiALN	3	1/2	1-1/4
1-1/4	55778	55778-TiALN	3-1/4	3/4	1-1/4

All dimensions in inches.
 Many tools are available with additional coatings.
 Please call for quote.



4-Flute — Machine Countersinks Straight Shank

KEO 4-flute center countersinks are versatile tools designed for countersinking holes for centers or for enlarging existing holes.

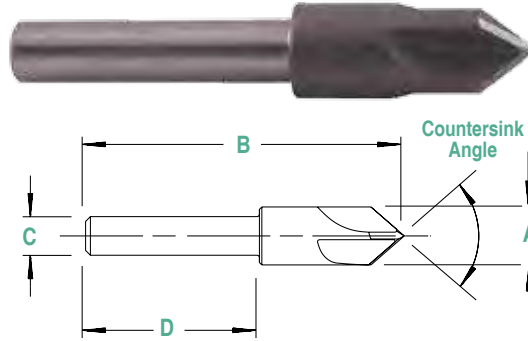

60°, 82° and 90° Countersink Angles

A	Product Number												B	C	D
Body Dia.	60°				82°				90°				OAL	Shank Dia.	Shank Length
	HSS	HSS-TiN	CO	CO-TiN	HSS	HSS-TiN	CO	CO-TiN	HSS	HSS-TiN	CO	CO-TiN			
1/2	40126	40126-TiN	55250	55250-TiN	40128	40128-TiN	55255	55255-TiN	40129	40129-TiN	55260	55260-TiN	3-7/8	1/2	2-1/4
5/8	40586	40586-TiN	55251	55251-TiN	40588	40588-TiN	55256	55256-TiN	40589	40589-TiN	55261	55261-TiN	4	1/2	2-1/4
3/4	40346	40346-TiN	55252	55252-TiN	40348	40348-TiN	55257	55257-TiN	40349	40349-TiN	55262	55262-TiN	4-1/8	1/2	2-1/4
7/8	40786	40786-TiN	55253	55253-TiN	40788	40788-TiN	55258	55258-TiN	40789	40789-TiN	55263	55263-TiN	4-1/4	1/2	2-1/4
1	41006	41006-TiN	55254	55254-TiN	41008	41008-TiN	55259	55259-TiN	41009	41009-TiN	55264	55264-TiN	4-3/8	1/2	2-1/4

All dimensions in inches.

Many tools are available with additional coatings.

Please call for quote.

4-Flute Center Reamers

KEO 4-flute center reamers are versatile tools designed for countersinking holes for centers or for enlarging existing holes.

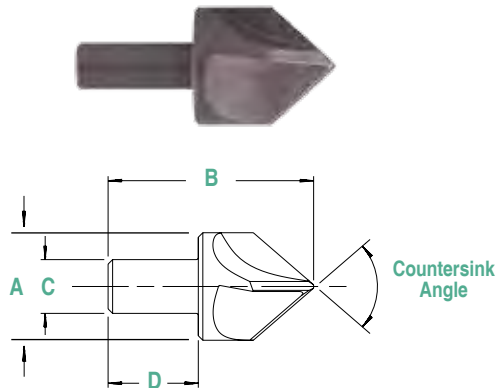

60°, 82° and 90° Countersink Angles

A	Product Number												B	B	C	D
Body Dia.	60°				82°				90°				60° OAL	82° and 90° OAL	Shank Dia.	Shank Length
	HSS	HSS-TiN	CO	CO-TiN	HSS	HSS-TiN	CO	CO-TiN	HSS	HSS-TiN	CO	CO-TiN				
1-1/4	51146	51146-TiN	55370	55370-TiN	51148	51148-TiN	55374	55374-TiN	51149	51149-TiN	55378	55378-TiN	3	2-3/4	1/2	1-1/4
1-1/2	51126	51126-TiN	55371	55371-TiN	51128	51128-TiN	55375	55375-TiN	51129	51129-TiN	55379	55379-TiN	3-1/4	2-7/8	3/4	1-1/4
1-3/4	51346	51346-TiN	55372	55372-TiN	51348	51348-TiN	55376	55376-TiN	51349	51349-TiN	55380	55380-TiN	3-1/2	3	3/4	1-1/4
2	52006	52006-TiN	55373	55373-TiN	52008	52008-TiN	55377	55377-TiN	52009	52009-TiN	55381	55381-TiN	3-3/4	3-1/4	3/4	1-1/4

All dimensions in inches.

Many tools are available with additional coatings.

Please call for quote.



6-Flute Countersinks — 60°, 82°, 90°, 100°, 110°, 120° Countersink Angles

KEO 6-flute line of countersinks are companions to our single flute countersinks and our 3- and 4-flute center reamer line. As a rule, the more edges per revolution, the greater amount of material that may be removed. We have designed the 6-flute tools with staggered cutting edges. See page 46 for set information.

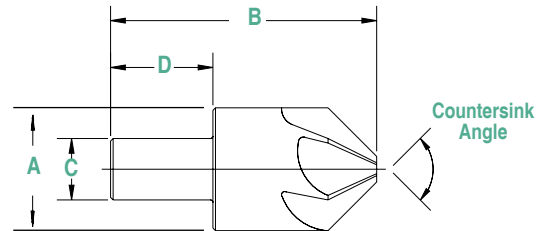

A Body Dia.	Product Number		B OAL	C Shank Dia.	D Shank Length
	60°				
	HSS	HSS-TiN			
1/8	55000	55000-TiN	1-1/4	1/8	N/A
3/16	55001	55001-TiN	1-3/8	3/16	N/A
1/4	55002	55002-TiN	1-1/2	1/4	N/A
5/16	55003	55003-TiN	1-3/4	1/4	7/8
3/8	55004	55004-TiN	1-3/4	1/4	7/8
1/2	55005	55005-TiN	2	1/4	1
1/2	55006	55006-TiN	2	3/8	1
5/8	55007	55007-TiN	2-1/4	1/4	1
5/8	55008	55008-TiN	2-1/4	3/8	1
3/4	55009	55009-TiN	2-5/8	1/2	1-1/4
7/8	55010	55010-TiN	2-3/4	1/2	1-1/4
1	55011	55011-TiN	2-3/4	1/2	1-1/4
1-1/4	55012	55012-TiN	3	1/2	1-1/4
1-1/2	55013	55013-TiN	3-1/4	3/4	1-1/4
1-3/4	55014	55014-TiN	3-1/2	3/4	1-1/4
2	55015	55015-TiN	3-3/4	3/4	1-1/4
2-1/2	55016	55016-TiN	5	1	1-1/2
3	55017	55017-TiN	5-1/4	1	1-1/2

All dimensions in inches.
Many tools are available with additional coatings.
Please call for quote.

A Body Dia.	Product Number										B OAL	C Shank Dia.	D Shank Length
	82°		90°		100°		110°		120°				
	HSS	HSS-TiN	HSS	HSS-TiN	HSS	HSS-TiN	HSS	HSS-TiN	HSS	HSS-TiN			
1/8	55020	55020-TiN	55040	55040-TiN	55060	55060-TiN	55080	55080-TiN	55100	55100-TiN	1-1/4	1/8	N/A
3/16	55021	55021-TiN	55041	55041-TiN	55061	55061-TiN	55081	55081-TiN	55101	55101-TiN	1-3/8	3/16	N/A
1/4	55022	55022-TiN	55042	55042-TiN	55062	55062-TiN	55082	55082-TiN	55102	55102-TiN	1-1/2	1/4	N/A
5/16	55023	55023-TiN	55043	55043-TiN	55063	55063-TiN	55083	55083-TiN	55103	55103-TiN	1-3/4	1/4	7/8
3/8	55024	55024-TiN	55044	55044-TiN	55064	55064-TiN	55084	55084-TiN	55104	55104-TiN	1-3/4	1/4	7/8
1/2	55025	55025-TiN	55045	55045-TiN	55065	55065-TiN	55085	55085-TiN	55105	55105-TiN	2	1/4	1
1/2	55026	55026-TiN	55046	55046-TiN	55066	55066-TiN	55086	55086-TiN	55106	55106-TiN	2	3/8	1
5/8	55027	55027-TiN	55047	55047-TiN	55067	55067-TiN	55087	55087-TiN	55107	55107-TiN	2-1/4	1/4	1
5/8	55028	55028-TiN	55048	55048-TiN	55068	55068-TiN	55088	55088-TiN	55108	55108-TiN	2-1/4	3/8	1
3/4	55029	55029-TiN	55049	55049-TiN	55069	55069-TiN	55089	55089-TiN	55109	55109-TiN	2-5/8	1/2	1-1/4
7/8	55030	55030-TiN	55050	55050-TiN	55070	55070-TiN	55090	55090-TiN	55110	55110-TiN	2-3/4	1/2	1-1/4
1	55031	55031-TiN	55051	55051-TiN	55071	55071-TiN	55091	55091-TiN	55111	55111-TiN	2-3/4	1/2	1-1/4
1-1/4	55032	55032-TiN	55052	55052-TiN	55072	55072-TiN	55092	55092-TiN	55112	55112-TiN	2-3/4	1/2	1-1/4
1-1/2	55033	55033-TiN	55053	55053-TiN	55073	55073-TiN	55093	55093-TiN	55113	55113-TiN	2-7/8	3/4	1-1/4
1-3/4	55034	55034-TiN	55054	55054-TiN	55074	55074-TiN	55094	55094-TiN	55114	55114-TiN	3	3/4	1-1/4
2	55035	55035-TiN	55055	55055-TiN	55075	55075-TiN	55095	55095-TiN	55115	55115-TiN	3-1/4	3/4	1-1/4
2-1/2	55036	55036-TiN	55056	55056-TiN	55076	55076-TiN	55096	55096-TiN	55116	55116-TiN	5	1	1-1/2
3	55037	55037-TiN	55057	55057-TiN	55077	55077-TiN	55097	55097-TiN	55117	55117-TiN	5-1/4	1	1-1/2



Cobalt 6-Flute Countersinks — 60°, 82°, 90°, 100°, 110°, 120° Countersink Angles

A	Product Number												B	C	D
	60°		82°		90°		100°		110°		120°				
Body Dia.	CO	CO-TiN	CO	CO-TiN	CO	CO-TiN	CO	CO-TiN	CO	CO-TiN	CO	CO-TiN			
1/8	55500	55500-TiN	55520	55520-TiN	55540	55540-TiN	55560	55560-TiN	55580	55580-TiN	55600	55600-TiN	1-1/4	1/8	N/A
3/16	55501	55501-TiN	55521	55521-TiN	55541	55541-TiN	55561	55561-TiN	55581	55581-TiN	55601	55601-TiN	1-3/8	3/16	N/A
1/4	55502	55502-TiN	55522	55522-TiN	55542	55542-TiN	55562	55562-TiN	55582	55582-TiN	55602	55602-TiN	1-1/2	1/4	N/A
5/16	55503	55503-TiN	55523	55523-TiN	55543	55543-TiN	55563	55563-TiN	55583	55583-TiN	55603	55603-TiN	1-3/4	1/4	7/8
3/8	55504	55504-TiN	55524	55524-TiN	55544	55544-TiN	55564	55564-TiN	55584	55584-TiN	55604	55604-TiN	1-3/4	1/4	7/8
1/2	55505	55505-TiN	55525	55525-TiN	55545	55545-TiN	55565	55565-TiN	55585	55585-TiN	55605	55605-TiN	2	1/4	1
1/2	55506	55506-TiN	55526	55526-TiN	55546	55546-TiN	55566	55566-TiN	55586	55586-TiN	55606	55606-TiN	2	3/8	1
5/8	55507	55507-TiN	55527	55527-TiN	55547	55547-TiN	55567	55567-TiN	55587	55587-TiN	55607	55607-TiN	2-1/4	1/4	1
5/8	55508	55508-TiN	55528	55528-TiN	55548	55548-TiN	55568	55568-TiN	55588	55588-TiN	55608	55608-TiN	2-1/4	3/8	1
3/4	55509	55509-TiN	55529	55529-TiN	55549	55549-TiN	55569	55569-TiN	55589	55589-TiN	55609	55609-TiN	2-5/8	1/2	1-1/4
7/8	55510	55510-TiN	55530	55530-TiN	55550	55550-TiN	55570	55570-TiN	55590	55590-TiN	55610	55610-TiN	2-3/4	1/2	1-1/4
1	55511	55511-TiN	55531	55531-TiN	55551	55551-TiN	55571	55571-TiN	55591	55591-TiN	55611	55611-TiN	2-3/4	1/2	1-1/4
1-1/4	55512	55512-TiN	55532	55532-TiN	55552	55552-TiN	55572	55572-TiN	55592	55592-TiN	55612	55612-TiN	2-3/4	1/2	1-1/4
1-1/2	55513	55513-TiN	55533	55533-TiN	55553	55553-TiN	55573	55573-TiN	55593	55593-TiN	55613	55613-TiN	2-7/8	3/4	1-1/4
1-3/4	55514	55514-TiN	55534	55534-TiN	55554	55554-TiN	55574	55574-TiN	55594	55594-TiN	55614	55614-TiN	3	3/4	1-1/4
2	55515	55515-TiN	55535	55535-TiN	55555	55555-TiN	55575	55575-TiN	55595	55595-TiN	55615	55615-TiN	3-1/4	3/4	1-1/4
2-1/2	55516	55516-TiN	55536	55536-TiN	55556	55556-TiN	55576	55576-TiN	55596	55596-TiN	55616	55616-TiN	5	1	1-1/2
3	55517	55517-TiN	55537	55537-TiN	55557	55557-TiN	55577	55577-TiN	55597	55597-TiN	55617	55617-TiN	5-1/4	1	1-1/2

All dimensions in inches.

Many tools are available with additional coatings.

Please call for quote.

Carbide 6-Flute Countersinks — 60°, 82°, 90°, 100° Countersink Angles

A	Product Number								B	B	C	D
	60°		82°		90°		100°					
Body Dia.	CAR	CAR-TiALN	CAR	CAR-TiALN	CAR	CAR-TiALN	CAR	CAR-TiALN				
1/8	55780	55780-TiALN	55791	55791-TiALN	55802	55802-TiALN	55813	55813-TiALN	1-1/2	1-1/2	1/8	N/A
3/16	55781	55781-TiALN	55792	55792-TiALN	55803	55803-TiALN	55814	55814-TiALN	2	2	3/16	N/A
1/4	55782	55782-TiALN	55793	55793-TiALN	55804	55804-TiALN	55815	55815-TiALN	2	2	1/4	N/A
3/8	55783	55783-TiALN	55794	55794-TiALN	55805	55805-TiALN	55816	55816-TiALN	2-3/4	2-5/8	1/4	7/8
1/2	55784	55784-TiALN	55795	55795-TiALN	55806	55806-TiALN	55817	55817-TiALN	2-3/4	2-5/8	1/4	1
5/8	55785	55785-TiALN	55796	55796-TiALN	55807	55807-TiALN	55818	55818-TiALN	2-7/8	2-3/4	3/8	1
3/4	55786	55786-TiALN	55797	55797-TiALN	55808	55808-TiALN	55819	55819-TiALN	3	2-3/4	3/8	1-1/4
1	55787	55787-TiALN	55798	55798-TiALN	55809	55809-TiALN	55820	55820-TiALN	3-1/4	3	1/2	1-1/4
1-1/4	55788	55788-TiALN	55799	55799-TiALN	55810	55810-TiALN	55821	55821-TiALN	3-3/4	3-1/4	3/4	1-1/4
1-1/2	55789	55789-TiALN	55800	55800-TiALN	55811	55811-TiALN	55822	55822-TiALN	3-3/4	3-1/4	3/4	1-1/4

All dimensions in inches.

Many tools are available with additional coatings.

Please call for quote.



KOUNTERBORE

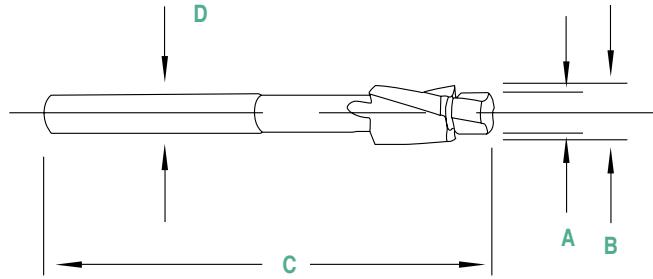

Precision 3-Flute Cap Screw Kounterbores

- Integral Pilot, Straight Shank, CNC Precision Ground, Cobalt HSS
- Micro-smooth CNC precision ground for precision smooth counterboring.
- Cobalt
- High performance cutting action due to secondary relief behind cutting edge margin.
- Optimized helix for chip evacuation — chips flow away from cut without wrapping around tool.

All dimensions in inches.
 Many tools are available with coatings.
 Please call for quote.

See page 47 for set information.

Size/Application	Product Number	Screw Size	A Pilot Dia.	B C'bore Dia.	C OAL	D Shank Dia.	Assembly Criteria
#4 Nominal	55200	#4	0.112	0.186	3	5/32	Close Fit
#4 +1/64 O/S	55201	#4	0.127	0.202	3	5/32	1/64" Clearance
#4 +1/32 O/S	55202	#4	0.143	0.217	3	5/32	1/32" Clearance
#5 Nominal	55203	#5	0.125	0.205	3	3/16	Close Fit
#5 +1/64 O/S	55204	#5	0.140	0.221	3	3/16	1/64" Clearance
#5 +1/32 O/S	55205	#5	0.156	0.237	3	3/16	1/32" Clearance
#6 Nominal	55206	#6	0.138	0.228	3	7/32	Close Fit
#6 +1/64 O/S	55207	#6	0.153	0.244	3	7/32	1/64" Clearance
#6 +1/32 O/S	55208	#6	0.169	0.260	3	7/32	1/32" Clearance
#8 Nominal	55209	#8	0.164	0.272	3	1/4	Close Fit
#8 +1/64 O/S	55210	#8	0.179	0.288	3	1/4	1/64" Clearance
#8 +1/32 O/S	55211	#8	0.195	0.304	3	1/4	1/32" Clearance
#10 Nominal	55212	#10	0.190	0.314	4.5	9/32	Close Fit
#10 +1/64 O/S	55213	#10	0.205	0.330	4.5	9/32	1/64" Clearance
#10 +1/32 O/S	55214	#10	0.221	0.346	4.5	9/32	1/32" Clearance
1/4" Nominal	55215	1/4	0.250	0.382	4.5	5/16	Close Fit
1/4" +1/64 O/S	55216	1/4	0.265	0.398	4.5	5/16	1/64" Clearance
1/4" +1/32 O/S	55217	1/4	0.281	0.414	4.5	5/16	1/32" Clearance
5/16" Nominal	55218	5/16	0.312	0.475	4.5	3/8	Close Fit
5/16" +1/64 O/S	55219	5/16	0.328	0.491	4.5	3/8	1/64" Clearance
5/16" +1/32 O/S	55220	5/16	0.343	0.507	4.5	3/8	1/32" Clearance
3/8" Nominal	55221	3/8	0.375	0.572	5	1/2	Close Fit
3/8" +1/64 O/S	55222	3/8	0.390	0.588	5	1/2	1/64" Clearance
3/8" +1/32 O/S	55223	3/8	0.406	0.604	5	1/2	1/32" Clearance
7/16" Nominal	55224	7/16	0.437	0.663	5	1/2	Close Fit
7/16" +1/64 O/S	55225	7/16	0.452	0.679	5	1/2	1/64" Clearance
7/16" +1/32 O/S	55226	7/16	0.468	0.695	5	1/2	1/32" Clearance
1/2" Nominal	55227	1/2	0.500	0.757	6	1/2	Close Fit
1/2" +1/64 O/S	55228	1/2	0.515	0.773	6	1/2	1/64" Clearance
1/2" +1/32 O/S	55229	1/2	0.531	0.789	6	1/2	1/32" Clearance
5/8" Nominal	55230	5/8	0.625	0.945	6	5/8	Close Fit
5/8" +1/64 O/S	55231	5/8	0.641	0.961	6	5/8	1/64" Clearance
5/8" +1/32 O/S	55232	5/8	0.656	0.977	6	5/8	1/32" Clearance
3/4" Nominal	55233	3/4	0.766	1.187	7	3/4	Close Fit
3/4" +1/32 O/S	55234	3/4	0.781	1.203	7	3/4	1/32" Clearance
7/8" Nominal	55235	7/8	0.891	1.375	7	7/8	Close Fit
7/8" +1/32 O/S	55236	7/8	0.906	1.391	7	7/8	1/32" Clearance
1" Nominal	55237	1	1.016	1.562	7	1	Close Fit
1" +1/32 O/S	55238	1	1.032	1.588	7	1	1/32" Clearance



Precision 3-Flute Cap Screw Kounterbores — Metric



KOUNTERBORE **RE**

		A	B	C	D
Application	Product Number	Pilot Dia.	C'bore Dia.	OAL	Shank Dia.
M3 - Before Thread	56200	2.5	6	71	5
M3 - Fine	56201	3.2	6	71	5
M3 - Medium	56202	3.4	6	71	5
M3.5 - Before Thread	56203	2.9	6.5	71	5
M3.5 - Fine	56204	3.7	6.5	71	5
M3.5 - Medium	56205	3.9	6.5	71	5
M4 - Before Thread	56206	3.3	8	71	5
M4 - Fine	56207	4.3	8	71	5
M4 - Medium	56208	4.5	8	71	5
M5 - Before Thread	56209	4.2	10	80	8
M5 - Fine	56210	5.3	10	80	8
M5 - Medium	56211	5.5	10	80	8
M6 - Before Thread	56212	5	11	80	8
M6 - Fine	56213	6.4	11	80	8
M6 - Medium	56214	6.6	11	80	8
M8 - Before Thread	56215	6.8	15	100	12.5
M8 - Fine	56216	8.4	15	100	12.5
M8 - Medium	56217	9	15	100	12.5
M10 - Before Thread	56218	8.5	18	100	12.5
M10 - Fine	56219	10.5	18	100	12.5
M10 - Medium	56220	11	18	100	12.5
M12 - Before Thread	56221	10.2	20	100	12.5
M12 - Fine	56222	13	20	100	12.5
M12 - Medium	56223	14	20	100	12.5

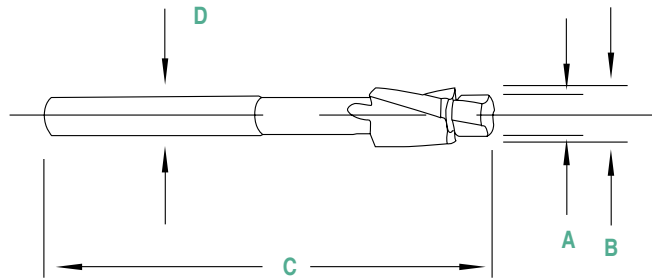

All dimensions in millimeters.
 Many tools are available with coatings.
 Please call for quote.

See page 47 for set information.







MILLING CUTTERS

Milling Cutters.....	37
Woodruff Keyseat Cutters.....	38
Woodruff Keyseat Cutters Carbide	39
Woodruff Keyseat Cutters Metric	39
Narrow Width Keyseat Cutters.....	40
Small Solid Carbide Keyseat Cutters	41
Dovetail Cutters	42
T-Slot Milling Cutters.....	43

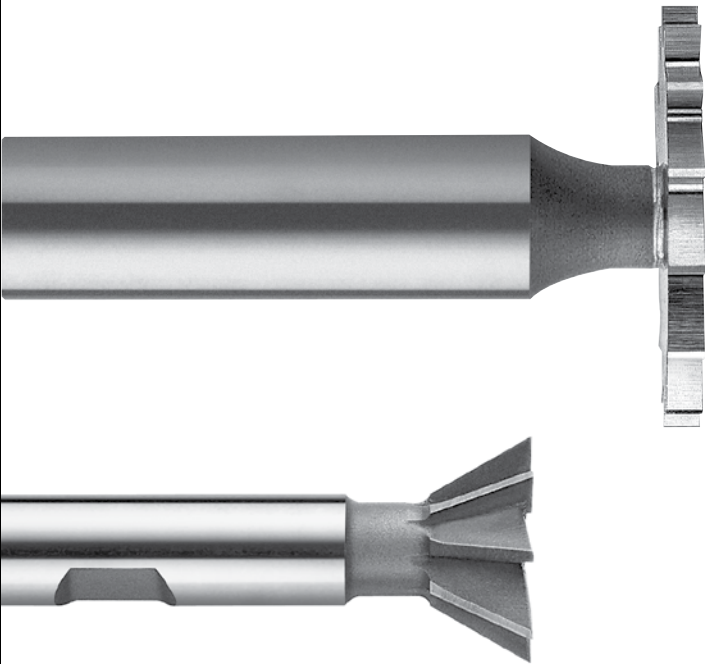



Woodruff Keyseat Cutters — Shank Type

KEO woodruff keyseat cutters are extremely versatile profile milling cutters. Although originally designed to mill standard woodruff keyseat, they now satisfy a variety of applications from milling slots to milling threads. For set information see page 47.

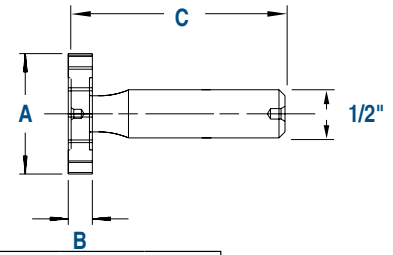

American Standard #	A Head Dia.	B Face Width	C OAL	HSS		HSS-LH	Cobalt		# of Teeth		Carbide Tipped		
				Straight Tooth	Stagger Tooth	Straight Tooth	Straight Tooth	Stagger Tooth	Straight	Stagger	Straight Tooth	Stagger Tooth	# of Teeth
202	1/4	1/16	2-1/16	62010	62015	93928	93932	93933	8	6			
202 1/2	5/16	1/16	2-1/16	62020	62025	93934	93938	93939	8	6			
302 1/2	5/16	3/32	2-3/32	63020	63025	93940	93944	93945	8	6			
203	3/8	1/16	2-1/16	62030	62035	93946	93950	93951	8	6			
303	3/8	3/32	2-3/32	63030	63035	93952	93956	93957	8	6			
403	3/8	1/8	2-1/8	64030	64035	93958	93962	93963	8	6			
204	1/2	1/16	2-1/16	62040	62045	93964	93968	93969	10	8	93971	93972	6
304	1/2	3/32	2-3/32	63040	63045	93970	93974	93975	10	8	93977	93978	6
404	1/2	1/8	2-1/8	64040	64045	93982	93986	93987	10	8	93983	93984	6
305	5/8	3/32	2-3/32	63050	63055	93976	93980	93981	10	8	93989	93990	6
405	5/8	1/8	2-1/8	64050	64055	93988	93992	93993	10	8	93995	93996	6
505	5/8	5/32	2-5/32	65050	65055	94000	94004	94005	10	8	94001	94002	6
605	5/8	3/16	2-3/16	66050	66055	94006	94010	94011	10	8	94007	94008	6
406	3/4	1/8	2-1/8	64060	64065	93994	93998	93999	10	8	94013	94014	6
506	3/4	5/32	2-5/32	65060	65065	94012	94016	94017	10	8	94019	94020	6
606	3/4	3/16	2-3/16	66060	66065	94030	94034	94035	10	8	94025	94026	6
806	3/4	1/4	2-1/4	68060	68065	94018	94022	94023	10	8	94031	94032	6
507	7/8	5/32	2-5/32	65070	65075	94024	94028	94029	12	10	94037	94038	6
607	7/8	3/16	2-3/16	66070	66075	94036	94040	94041	12	10	94043	94044	6
707	7/8	7/32	2-7/32	67070	67075	94042	94046	94047	12	10	94049	94050	6
807	7/8	1/4	2-1/4	68070	68075	94072	94076	94077	12	10	94055	94056	6
608	1	3/16	2-3/16	66080	66085	94048	94052	94053	12	10	94061	94062	8
708	1	7/32	2-7/32	67080	67085	94054	94058	94059	12	10	94067	94068	8
808	1	1/4	2-1/4	68080	68085	94078	94082	94083	12	10	94073	94074	8
1008	1	5/16	2-5/16	60080	60085	94126	94130	94131	12	10	94079	94080	8
1208	1	3/8	2-3/8	62080	62085	94060	94064	94065	12	10	94085	94086	8
609	1-1/8	3/16	2-3/16	66090	66095	94066	94070	94071	12	10	94091	94092	8
709	1-1/8	7/32	2-7/32	67090	67095	94084	94088	94089	12	10	94097	94098	8
809	1-1/8	1/4	2-1/4	68090	68095	94090	94094	94095	12	10	94103	94104	8
1009	1-1/8	5/16	2-5/16	60090	60095	94132	94136	94137	12	10	94109	94110	8
610	1-1/4	3/16	2-3/16	66100	66105	94096	94100	94101	14	12	94115	94116	8
710	1-1/4	7/32	2-7/32	67100	67105	94102	94106	94107	14	12	94121	94122	8
810	1-1/4	1/4	2-1/4	68100	68105	94108	94112	94113	14	12	94127	94128	8
1010	1-1/4	5/16	2-5/16	60010	60015	94138	94142	94143	14	12	94133	94134	8
1210	1-1/4	3/8	2-3/8	62100	62105	94156	94160	94161	14	12	94139	94140	8
811	1-3/8	1/4	2-1/4	68110	68115	94114	94118	94119	14	12	94145	94146	8
1011	1-3/8	5/16	2-5/16	60110	60115	94144	94148	94149	14	12	94151	94152	8
1211	1-3/8	3/8	2-3/8	62110	62115	94162	94166	94167	14	12	94157	94158	8
812	1-1/2	1/4	2-1/4	68120	68125	94120	94124	94125	16	14	94163	94164	8
1012	1-1/2	5/16	2-5/16	60120	60125	94150	94154	94155	16	14	94169	94170	8
1212	1-1/2	3/8	2-3/8	62120	62125	94168	94172	94173	16	14	94174	94175	8

Cutter Diameter		Shank Diameter		Width	
1/4" up to and including 3/4"	+0.010"	+0.015"	1/16" up to and including 5/32"	+0.0000"	-0.0005"
7/8" up to and including 1-1/8"	+0.012"	+0.017"	3/16" up to and including 7/32"	-0.0002"	-0.0007"
1-1/4" up to and including 1-1/2"	+0.015"	+0.020"	1/4"	-0.0003"	-0.0008"
			5/16"	-0.0004"	-0.0009"
			3/8"	-0.0005"	-0.0010"

All dimensions in inches. Many tools are available with additional coatings. Please call for quote.



Carbide Woodruff Keyseat Cutters — Shank Type

	A	B	C	Carbide Head	Solid Carbide
American Standard #	Head Dia.	Face Width	OAL	Straight Tooth	Straight Tooth
204	1/2	1/16	2-1/16	61000	
304	1/2	3/32	2-3/32	61001	
404	1/2	1/8	2-1/8	61002	
305	5/8	3/32	2-3/32	61003	
405	5/8	1/8	2-1/8	61004	
505	5/8	5/32	2-5/32	61005	
605	5/8	3/16	2-3/16	61006	
406	3/4	1/8	2-1/8	61007	
506	3/4	5/32	2-5/32	61008	
606	3/4	3/16	2-3/16	61009	
806	3/4	1/4	2-1/4	61010	
507	7/8	5/32	2-5/32	61011	
607	7/8	3/16	2-3/16	61012	
707	7/8	7/32	2-7/32	61013	
807	7/8	1/4	2-1/4	61014	
608	1	3/16	2-3/16	61015	
708	1	7/32	2-7/32	61016	
808	1	1/4	2-1/4	61017	
1008	1	5/16	2-5/16	61018	
1208	1	3/8	2-3/8	61019	
609	1-1/8	3/16	2-3/16		61020
709	1-1/8	7/32	2-7/32		61021
809	1-1/8	1/4	2-1/4		61022
1009	1-1/8	5/16	2-5/16		61023
610	1-1/4	3/16	2-3/16		61024
710	1-1/4	7/32	2-7/32		61025
810	1-1/4	1/4	2-1/4		61026
1010	1-1/4	5/16	2-5/16		61027
1210	1-1/4	3/8	2-3/8		61028
811	1-3/8	1/4	2-1/4		61029
1011	1-3/8	5/16	2-5/16		61030
1211	1-3/8	3/8	2-3/8		61031
812	1-1/2	1/4	2-1/4		61032
1012	1-1/2	5/16	2-5/16		61033
1212	1-1/2	3/8	2-3/8		61034

All dimensions in inches.
 Shank Diameter (D) is 1/2".
 Shank Length (E) is 2".
 Many tools are available with additional coatings.
 Please call for quote.

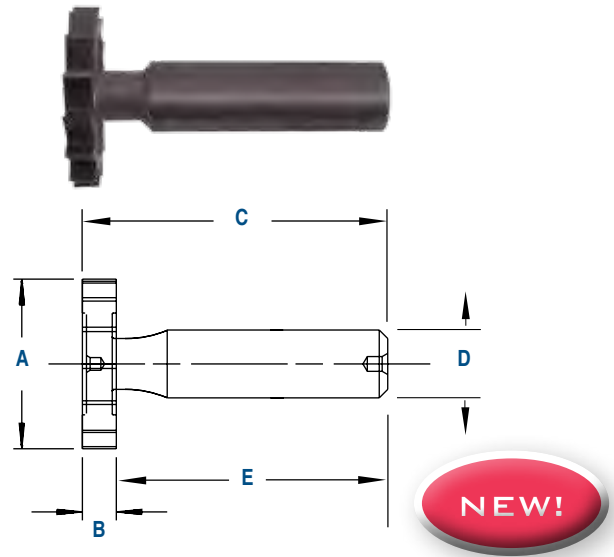

Metric Keyseat Cutters — HSS Shank Type DIN850 – Form A, B

A	B	C	D	# of Teeth			
				Straight	Stagger	Straight	Stagger
4.5	1	50	6	68200	68201	6	4
7.5	1.5	50	6	68210	68211	8	6
7.5	2	50	6	68220	68221	8	6
10.5	2	50	6	68230	68231	8	6
10.5	2.5	50	6	68240	68241	8	6
10.5	3	50	6	68250	68251	8	6
13.5	3	56	10	68260	68261	10	8
13.5	4	56	10	68270	68271	10	8
16.5	3	56	10	68280	68281	10	8
16.5	4	56	10	68290	68291	10	8
16.5	5	56	10	68300	68301	10	8
19.5	4	63	10	68310	68311	10	8
19.5	5	63	10	68320	68321	10	8
19.5	6	63	10	68330	68331	10	8
22.5	5	63	10	68340	68341	12	10
22.5	6	63	10	68350	68351	12	10
22.5	8	63	10	68360	68361	12	10
25.5	6	63	10	68370	68371	12	10
28.5	6	71	10	68380	68381	12	10
28.5	8	71	10	68390	68391	12	10
28.5	10	71	12	68400	68401	12	10
32.5	7	71	12	68410	68411	14	12
32.5	8	71	12	68420	68421	14	12
32.5	10	71	12	68430	68431	14	12
45.5	10	71	12	68440	68441	18	16

All dimensions in millimeters.



Narrow Width Keyseat Cutters — Shank Type

KEO narrow width keyseat cutters provide many standard width and diameter combinations to accommodate a variety of milling requirements.

A		B	
Head Dia.	Product Number	Head Width	Teeth (RH)
1/4	68981	1/64	Str.-8
1/4	68978	0.020	Str.-8
1/4	68982	1/32	Str.-8
1/4	68983	3/64	Str.-8
5/16	68984	1/64	Str.-8
5/16	68979	0.020	Str.-8
5/16	68985	1/32	Str.-8
5/16	68986	3/64	Str.-8
3/8	68987	1/64	Str.-8
3/8	68980	0.020	Str.-8
3/8	68988	1/32	Str.-8
3/8	68989	3/64	Str.-8
1/2	68990	1/64	Str.-10
1/2	68991	0.020	Str.-10
1/2	69000	1/32	Str.-10
1/2	69001	3/64	Str.-10
5/8	69009	0.020	Str.-10
5/8	69010	1/32	Str.-10
5/8	69011	3/64	Str.-10
5/8	69020	1/16	Str.-10
5/8	69021	5/64	Str.-10
3/4	69030	1/32	Str.-10
3/4	69031	3/64	Str.-10
3/4	69040	1/16	Str.-10
3/4	69041	5/64	Str.-10
3/4	69050	3/32	Str.-10
3/4	69051	7/64	Str.-10
7/8	69060	1/32	Str.-12
7/8	69061	3/64	Str.-12
7/8	69070	1/16	Str.-12
7/8	69071	5/64	Str.-12
7/8	69080	3/32	Str.-12
7/8	69081	7/64	Str.-12
7/8	69090	1/8	Str.-12
7/8	69091	9/64	Str.-12
1	69098	1/32	Str.-12
1	69099	3/64	Str.-12
1	69100	1/16	Str.-12
1	69101	5/64	Str.-12
1	69110	3/32	Str.-12
1	69111	7/64	Str.-12
1	69120	1/8	Str.-12
1	69121	9/64	Str.-12
1	69130	5/32	Str.-12
1	69131	11/64	Str.-12

A		B	
Head Dia.	Product Number	Head Width	Teeth (RH)
1-1/8	69139	3/64	Str.-12
1-1/8	69140	1/16	Str.-12
1-1/8	69141	5/64	Str.-12
1-1/8	69150	3/32	Str.-12
1-1/8	69151	7/64	Str.-12
1-1/8	69160	1/8	Str.-12
1-1/8	69161	9/64	Str.-12
1-1/8	69170	5/32	Str.-12
1-1/8	69171	11/64	Str.-12
1-1/4	69179	3/64	Str.-14
1-1/4	69180	1/16	Str.-14
1-1/4	69181	5/64	Str.-14
1-1/4	69190	3/32	Str.-14
1-1/4	69191	7/64	Str.-14
1-1/4	69200	1/8	Str.-14
1-1/4	69201	9/64	Str.-14
1-1/4	69210	5/32	Str.-14
1-1/4	69211	11/64	Str.-14
1-3/8	69219	3/64	Str.-14
1-3/8	69220	1/16	Str.-14
1-3/8	69221	5/64	Str.-14
1-3/8	69230	3/32	Str.-14
1-3/8	69231	7/64	Str.-14
1-3/8	69240	1/8	Str.-14
1-3/8	69241	9/64	Str.-14
1-3/8	69250	5/32	Str.-14
1-3/8	69251	11/64	Str.-14
1-3/8	69260	3/16	Str.-14
1-3/8	69261	13/64	Str.-14
1-3/8	69270	7/32	Str.-14
1-1/2	69279	3/64	Str.-16
1-1/2	69280	1/16	Str.-16
1-1/2	69281	5/64	Str.-16
1-1/2	69290	3/32	Str.-16
1-1/2	69291	7/64	Str.-16
1-1/2	69300	1/8	Str.-16
1-1/2	69301	9/64	Str.-16
1-1/2	69310	5/32	Str.-16
1-1/2	69311	11/64	Str.-16
1-1/2	69320	3/16	Str.-16
1-1/2	69321	13/64	Str.-16
1-1/2	69330	7/32	Str.-16
1-1/2	69331	15/64	Str.-16

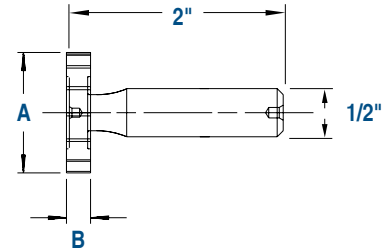

All dimensions in inches.

Many tools are available with additional coatings. Please call for quote.



Small Solid Carbide Keyseat Cutters — Shank Type

A		B	C	D	
Head Dia.	Product Number	Head Width	Shank Dia.	Neck Dia.	Teeth
1/8	61070	1/64	1/4	1/16	6
1/8	61071	1/32	1/4	1/16	6
1/8	61072	1 mm	1/4	1/16	6
1/8	61073	3/64	1/4	1/16	6
1/8	61074	1/16	1/4	1/16	6
3/16	61075	1/64	1/4	3/32	6
3/16	61076	1/32	1/4	3/32	6
3/16	61077	1 mm	1/4	3/32	6
3/16	61078	3/64	1/4	3/32	6
3/16	61079	1/16	1/4	3/32	6
1/4	61080	1/64	1/4	1/8	8
1/4	61081	1/32	1/4	1/8	8
1/4	61082	1 mm	1/4	1/8	8
1/4	61083	3/64	1/4	1/8	8
1/4	61084	1/16	1/4	1/8	8
5/16	61085	1/64	3/8	5/32	8
5/16	61086	1/32	3/8	5/32	8
5/16	61087	1 mm	3/8	5/32	8
5/16	61088	3/64	3/8	5/32	8
5/16	61089	1/16	3/8	5/32	8
5/16	61090	2 mm	3/8	5/32	8
5/16	61091	3/32	3/8	5/32	8
3/8	61092	1/64	3/8	3/16	8
3/8	61093	1/32	3/8	3/16	8
3/8	61094	1 mm	3/8	3/16	8
3/8	61095	3/64	3/8	3/16	8
3/8	61096	1/16	3/8	3/16	8
3/8	61097	2 mm	3/8	3/16	8
3/8	61098	3/32	3/8	3/16	8
3/8	61099	1/8	3/8	3/16	8

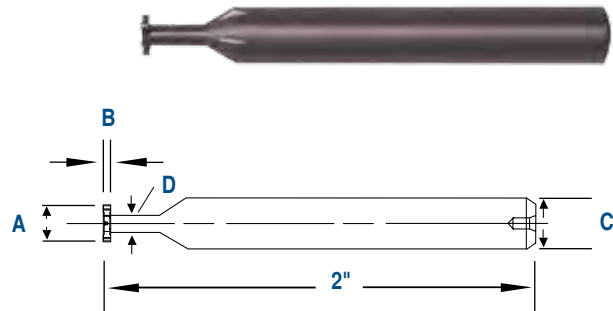

All dimensions in inches (except where millimeters indicated).
 Many tools are available with additional coatings.
 Please call for quote.





Dovetail Cutters

Dovetail cutters are provided with 45° and 60° angles utilizing a right hand cutting action. You may choose from HSS, Cobalt or carbide tipped cutters. **Carbide tipped tools include a .020 radius.**

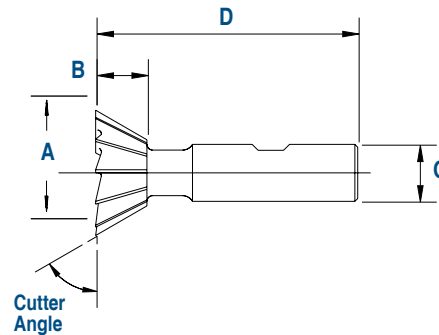

45° HSS and Cobalt

Product Number		A	B	C	D	
HSS	CO	Cutter Dia.	Cutter Width	Shank Dia.	OAL	Teeth
75034	76034	3/8	1/8	3/8	2-1/8	6
75044	76044	1/2	1/8	3/8	2-1/8	8
75064	76064	3/4	3/16	3/8	2-1/8	8
75084	76084	1	1/4	1/2	2-1/2	10
75114	76114	1-3/8	3/8	5/8	2-7/8	10
75154	76154	1-7/8	1/2	7/8	3-1/4	12
75184	76184	2-1/4	11/16	1	3-3/4	12
75204	76204	2-1/2	3/4	1	3-3/4	12
Cutter Dia.		+0.015	-0.015	Overall Length		±0.060
Shank Dia.		-0.0001	-0.0005			

All dimensions in inches.
 Many tools are available with additional coatings.
 Please call for quote.

45° Carbide Tipped

Product Number		A	B	C	D	
Carbide Tipped	Cutter Dia.	Cutter Width	Shank Dia.	OAL	Carbide Teeth	
74044	1/2	5/32	3/8	2-1/8	3	
74064	3/4	1/4	3/8	2-1/4	3	
74084	1	5/16	1/2	2-1/2	4	
74114	1-1/4	5/16	5/8	2-3/4	4	
74154	1-1/2	1/2	3/4	3-1/4	4	
74184	2	5/8	1	4-1/4	6	
74204	2-1/2	3/4	1-1/4	4-3/8	6	
74244	3	1	1-1/4	4-1/2	6	
Cutter Dia.		+0.015	-0.015	Overall Length		±0.060
Shank Dia.		-0.0001	-0.0005			

All dimensions in inches.
 Many tools are available with additional coatings.
 Please call for quote.

60° HSS and Cobalt

Product Number		A	B	C	D	
HSS	CO	Cutter Dia.	Cutter Width	Shank Dia.	OAL	Teeth
75036	76036	3/8	3/16	3/8	2-1/8	8
75046	76046	1/2	7/32	3/8	2-1/8	8
75066	76066	3/4	5/16	3/8	2-1/8	8
75086	76086	1	7/16	1/2	2-1/2	10
75116	76116	1-3/8	9/16	5/8	2-7/8	12
75156	76156	1-7/8	13/16	7/8	3-1/4	12
75186	76186	2-1/4	1-1/16	1	3-3/4	12
75206	76206	2-1/2	1-1/8	1	3-3/4	12
Cutter Dia.		+0.015	-0.015	Overall Length		±0.060
Shank Dia.		-0.0001	-0.0005			

All dimensions in inches.
 Many tools are available with additional coatings.
 Please call for quote.

60° Carbide Tipped

Product Number		A	B	C	D	
Carbide Tipped	Cutter Dia.	Cutter Width	Shank Dia.	OAL	Carbide Teeth	
74046	1/2	7/32	3/8	2-1/8	3	
74066	3/4	1/4	3/8	2-1/4	3	
74086	1	3/8	1/2	2-1/2	4	
74116	1-1/4	1/2	5/8	2-3/4	4	
74156	1-1/2	5/8	3/4	3-1/4	4	
74186	2	3/4	1	4-1/4	6	
74206	2-1/2	7/8	1-1/4	4-3/8	6	
74246	3	1-1/8	1-1/4	4-1/2	6	
Cutter Dia.		+0.015	-0.015	Overall Length		±0.060
Shank Dia.		-0.0001	-0.0005			

All dimensions in inches.
 Many tools are available with additional coatings.
 Please call for quote.



T-Slot Milling Cutters

KEO T-slot milling cutters have staggered teeth on the circumferential surface and teeth on both sides. The side teeth alternate to provide maximum chip clearance and stability to permit rapid milling of T-slots with minimum risk of breakage.

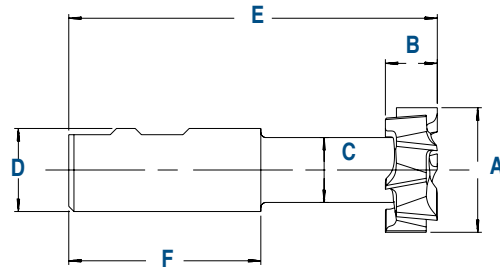

		A	B	C	D	E	F	
Bolt Size	Product Number	Head Dia.	Head Width	Neck Dia.	Shank Dia.	OAL	Shank Length	Teeth (RH)
1/4	70140	9/16	15/64	17/64	1/2	2-19/32	1-25/32	8
5/16	70560	21/32	17/64	21/64	1/2	2-11/16	1-25/32	8
3/8	70380	25/32	21/64	13/32	3/4	3-1/4	2-1/32	8
1/2	70120	31/32	25/64	17/32	3/4	3-7/16	2-1/32	8
5/8	70580	1-1/4	31/64	21/32	1	3-15/16	2-9/32	8
3/4	70340	1-15/32	5/8	25/32	1	4-7/16	2-9/32	8
1	71000	1-27/32	53/64	1-1/32	1-1/4	4-13/16	2-9/32	12
1-1/4	71140	2-7/32	1-3/32	1-7/32	1-1/4	5-3/8	2-9/32	12
1-1/2	71120	2-21/32	1-11/32	1-17/32	1-1/4	5-29/32	2-9/32	12
Cutter Dia.		+0.000	-0.010	Overall Length		±0.060	Helix Angle	10°
Shank Dia.		-0.0001	-0.0005	Width	+0.000	-0.005		

All dimensions in inches.

Many tools are available with additional coatings.

Please call for quote.



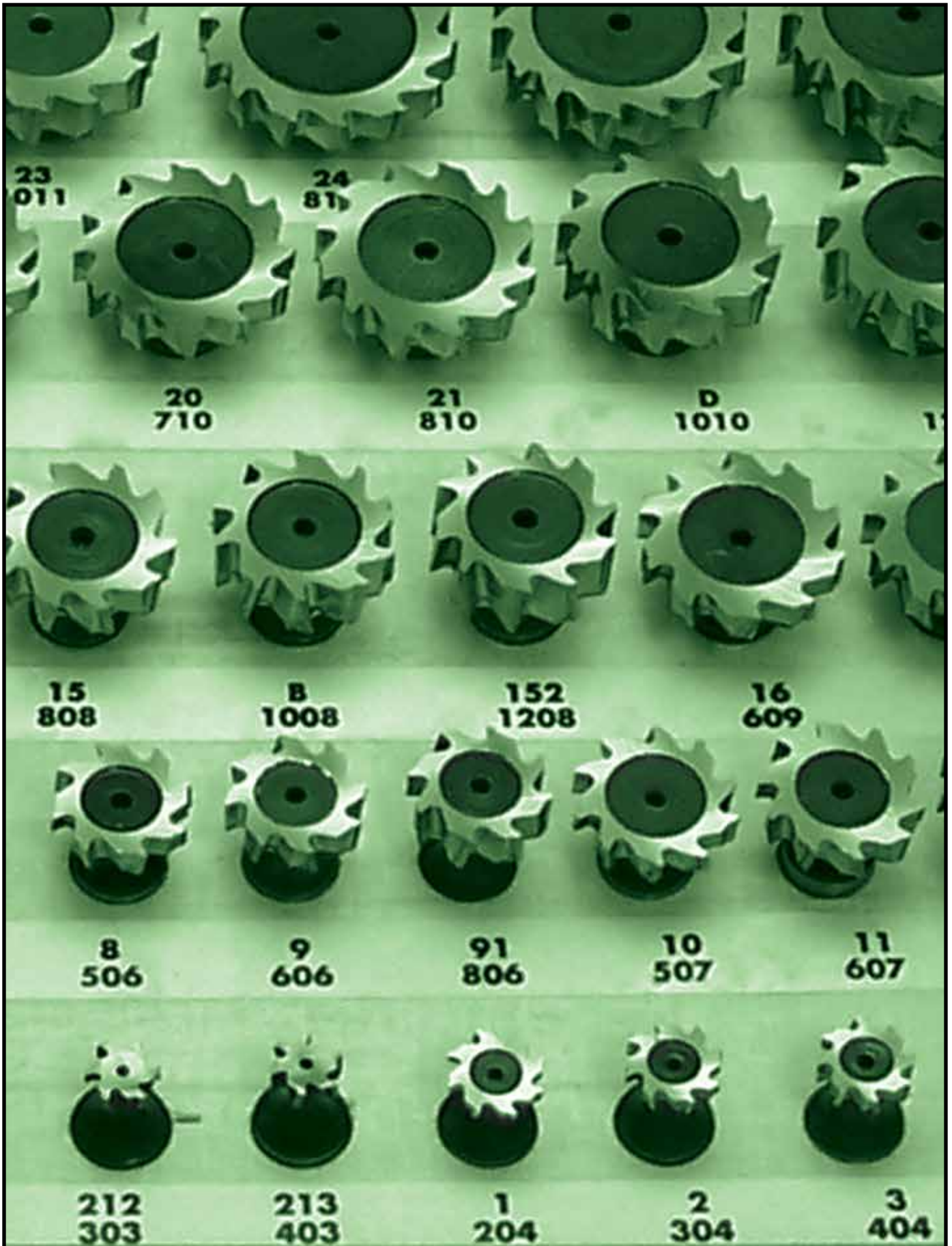



TOOL SETS

Table of Contents	Page
Tool Sets	45
Tool Sets	46, 47





Combined Drill & Countersink Sets

This 5-piece set includes one piece each of the following plain type combined drill with a standard 60° included countersink angle.

HSS	HSS-TiN	Cobalt	Carbide	C'Drills	PKG. QTY.
10000	10000-TiN	10002	10003	#1 #2 #3 #4 #5	1



For detailed information see pages 4 and 6.

Jig Bore Combined Drill & Countersink Sets

Each 5-piece set includes one piece each of the following jig bore type combined drill and countersinks.

Product Number	Body Dia.	Point Dia.
13000	3/8	1/16
		3/32
		1/8
		5/32
		3/16
12999	1/2	1/8
		3/16
		7/32
		1/4
		9/32



All dimensions in inches.

For detailed information see page 11.

HSS and Cobalt 3-Flute Center Reamer Sets

Each 5-piece set includes one piece each of 1/4, 3/8, 1/2, 3/4, 1" body diameter with a particular included point angle.

HSS	CO	Countersink Angle	PKG. QTY.
50026	50036	60°	1
50028	50038	82°	1
50029	50039	90°	1
50020	50030	100°	1
50021	50031	110°	1
50022	50032	120°	1



For detailed information see pages 27, 28 and 29.

HSS and Cobalt Single Flute Countersink Sets

Each 5-piece set includes one piece each of 1/4, 3/8, 1/2, 3/4, 1" body diameter with a particular included point angle.

HSS Single-Flute	CO Single-Flute	Countersink Angle	PKG. QTY.
53026	50056	60°	1
53028	50058	82°	1
53029	50059	90°	1
53020	50050	100°	1
53021	50051	110°	1
53022	50052	120°	1



For detailed information see pages 23, 24 and 25.

HSS and Cobalt 6-Flute Countersink Sets

HSS sets include one piece each of 1/4, 5/16, 3/8, 1/2, 5/8, 3/4, 1" body diameter with a particular included point angle. Cobalt sets include one piece each of 1/4, 5/16, 3/8, 1/2, 5/8, 3/4, 1" body diameter with a particular included point angle.

HSS 6-Flute	CO 6-Flute	Countersink Angle
55018	50046	60°
55038	50048	82°
55058	50049	90°
55078	50040	100°
55098	50041	110°
55118	50042	120°



For detailed information see pages 32 and 33. Many tools are available with additional coatings. Please call for quote.

Carbide Countersink Sets

Carbide set includes one 3/4, 5/8, 1/2, 3/8 and 1/4" body diameter with a particular included point angle.

Single-Flute	3-Flute	6-Flute	Countersink Angle	PKG. QTY.
55709	55749	55790	60°	1
55709-TiALN	55749-TiALN	55790-TiALN	60°	1
55719	55759	55801	82°	1
55719-TiALN	55759-TiALN	55801-TiALN	82°	1
55729	55769	55812	90°	1
55729-TiALN	55769-TiALN	55812-TiALN	90°	1
55739	55779	55823	100°	1
55739-TiALN	55779-TiALN	55823-TiALN	100°	1



For detailed information see pages 26, 30 and 33.



Flute Countersink & Deburring Tools

Straight Shank, CNC Precision Cam Ground, Cobalt, Chatter-free Cutting Action.

	Product Number			Countersink Angle
	4-Piece	5-Piece	5-Piece Coated	
	53508	53509	53509-TiN	60°
	53518	53519	53519-TiN	82°
	53528	53529	53529-TiN	90°
	53538	53539	53539-TiN	100°
Head Diameter	5/16, 3/8, 1/2, 5/8	5/16, 3/8, 1/2, 3/4, 1	5/16, 3/8, 1/2, 3/4, 1	All dimensions in inches. For detailed information see page 22.



Precision Cap Screw Kounterbores

Integral Pilot, Straight Shank, CNC Precision Ground, Cobalt HSS.

Product Number	Complete 7-Piece Tool Sets	Assembly Criteria	Pkg. Qty.
55239	#6, #8, #10, 1/4", 5/16", 3/8", 1/2" Nominal	Close Fit	1
55240	#6, #8, #10, 1/4", 5/16", 3/8", 1/2" +1/64 O/S	1/64" Clearance	1
55241	#6, #8, #10, 1/4", 5/16", 3/8", 1/2" +1/32 O/S	1/32" Clearance	1

For detailed information see page 34.



Precision Cap Screw Kounterbores — Metric

Integral Pilot, Straight Shank, CNC Precision Ground, Cobalt HSS.

Product Number	Complete 6-Piece Tool Sets	Application	Pkg. Qty.
56224	M3, M4, M5, M6, M8, M10	Before Thread	1
56225	M3, M4, M5, M6, M8, M10	Fine	1
56226	M3, M4, M5, M6, M8, M10	Medium	1

For detailed information see page 35.



10-Piece Woodruff Keyseat Cutter Sets

The 10-piece set includes one piece each of the following sizes with straight or staggered teeth.

American Standard Sizes		Product Number	Teeth
403	406	60100	Straight
204	606	60105	Staggered
404	806		
305	608		
505	808		

For detailed information see page 38.



41-Piece Woodruff Keyseat Cutter Sets

The 41-piece set includes one piece each of all the American Standard woodruff keyseat cutter sizes with straight or staggered teeth.

Product Number	Teeth
60000	Straight
60005	Staggered

For detailed information see page 38.

Many tools are available with additional coatings. Please call for quote.





**KEO
HIGH PERFORMANCE
CNC GRINDING**

**KEO
*ROBOTICS***



**KEO
*ENGINEERING***

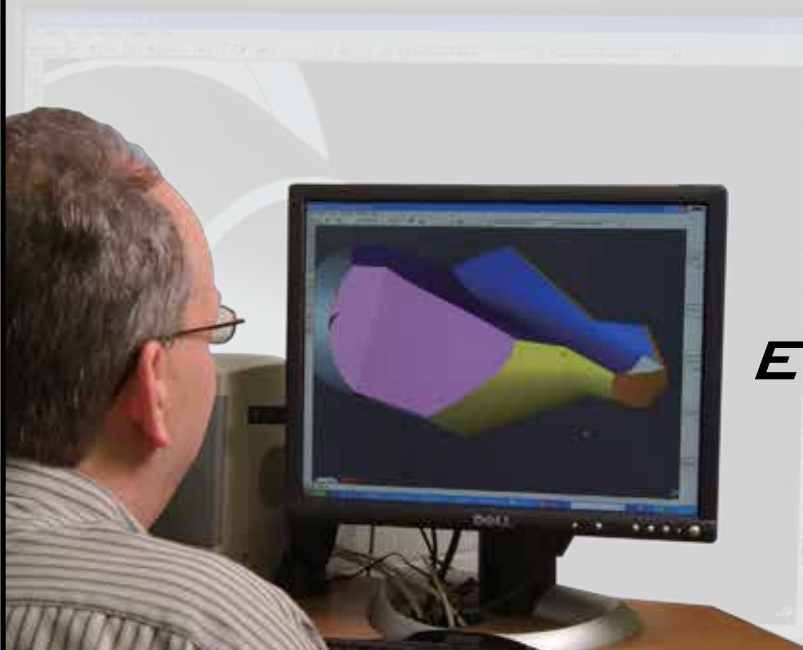



TECHNICAL INFORMATION

Table of Contents	Page
Technical Information	49
Drilling Time Formula	50
Speeds and Feeds	50, 51, 52
Climb Milling	52



Drilling Time Formula

Speeds and Feeds — Formula

If You Want To Find This:	And You Know This:	Do This:
Revolutions per minute (RPM)	SFM	$(\text{SFM} \times 12) \div (\text{Diameter of drill} \times 3.1416)$
Surface feet per minute (SFM)	RPM	$(\text{Diameter of drill} \times \text{RPM} \times 3.1416) \div 12$
Feed rate per RPM (FR)	SFM and FM	$(\text{Diameter of drill} \times \text{FM} \times 3.1416) \div (\text{SFM} \times 12)$
Feed rate per RPM (FR)	RPM and FM	$\text{FM} \div \text{RPM}$
Feed rate per minute (FM)	FR and RPM	$\text{RPM} \times \text{FR}$
SFM	RPM and drill dia.	$.26 \times \text{RPM} \times \text{drill diameter}$
RPM	SFM and drill dia.	$3.8 \times (\text{SFM} \div \text{drill diameter})$

Drill Speeds

Material.....	SFM*
Aluminum and Aluminum Alloys.....	150 – 300
Brass and Bronze (free cutting).....	150 – 300
Brass and Bronze (high tensile).....	70 – 120
Cast Iron (soft).....	80 – 120
Cast Iron (medium).....	60 – 90
Cast Iron (hard).....	30 – 70
Copper.....	70 – 100
Magnesium.....	200 – 400
Nickel Base Alloys.....	20 – 50
Plastic and Related Materials.....	100 – 200
Steel	
Alloyed — under 200 B.H.....	60 – 90
Alloyed — 200 – 300 B.H.....	40 – 70
Alloyed — over 300 B.H.....	20 – 30
Cast and Forged.....	40 – 70
Heat Treated — 35 – 40 R.C.....	30 – 40
Heat Treated — 40 – 45 R.C.....	20 – 30
Heat Treated — over 45 R.C.....	10 – 20
Mild — .2 – .3 Carbon.....	70 – 100
Mild — .4 – .5 Carbon.....	50 – 80
Stainless — 300 Series.....	20 – 50
Stainless — 400 Series.....	30 – 70
Tool — over 1.0 Carbon.....	40 – 60
Titanium Alloys.....	20 – 50
Wood.....	200 – 300

*Surface Feet per Minute

Drilling Time Formula

$$\text{Time (Minutes)} = \frac{\text{Travel (in.)}}{\text{RPM} \times \text{Feed (per rev.)}}$$

$$\text{Travel} = \text{Sum of: } \begin{array}{l} \text{Depth of Hole} \\ \text{1/3 Drill Diameter} \\ \text{Approach Clearance} \\ \text{Over Travel (through cavities)} \end{array} \div \text{Total Travel (in.)}$$

Drill Feeds

Diameter (in.)	Light Feed	Heavy Feed
1/8	.0005 – .0010	.0015
3/16	.0010 – .0015	.0020
1/4	.0015 – .0020	.0025
5/16	.0020 – .0025	.0030
7/16	.0025 – .0030	.0035
1/2	.0035 – .0040	.0045
5/8	.0045 – .0050	.0055
3/4	.0055 – .0060	.0065

The above are suggested starting ranges, and due to the many variables in an operation, more optimum speed may be established through trial.



Speeds and Feeds Information — Carbide

Materials	Drills Speed	Drills Diameter (IPR) Inches Inches Per Revolution		
		(SFM)	Up to 1/8"	Up to 1/4"
Aluminum & Aluminum	300 – 500	.0005 – .002	.002 – .003	.003 – .007
Alloys				
Brass/Bronze	200 – 400	.0005 – .002	.002 – .003	.003 – .007
Cast Iron (S)	125 – 300	.0005 – .002	.002 – .003	.003 – .007
Cast Iron (H)	100 – 200	.0005 – .002	.002 – .003	.003 – .007
Copper	150 – 300	.0005 – .002	.002 – .003	.003 – .007
Ductile Iron	75 – 180	.0005 – .002	.002 – .003	.003 – .007
Fiber	200 – 300	.0005 – .002	.002 – .003	.003 – .007
Graphite	200 – 400	.0005 – .002	.002 – .003	.003 – .007
Magnesium	300 – 500	.0005 – .002	.002 – .003	.003 – .007
Malleable Iron	75 – 180	.0005 – .002	.002 – .003	.003 – .007
Nickel	75 – 180	.0005 – .002	.002 – .003	.003 – .007
Plastic	200 – 500	.0005 – .002	.002 – .003	.003 – .007
Plastic Glass Filled	75 – 180	.0005 – .002	.002 – .003	.003 – .007
Rubber	200 – 300	.0005 – .002	.002 – .003	.003 – .007
Stainless Steel (S)	100 – 300	.0005 – .002	.002 – .003	.003 – .007
Stainless Steel (H)	50 – 100	.0005 – .002	.002 – .003	.003 – .007
Steel Low Carbon	125 – 300	.0005 – .002	.002 – .003	.003 – .007
Steel Med. Carbon	100 – 180	.0005 – .002	.002 – .003	.003 – .007
Titanium	30 – 100	.0005 – .002	.002 – .003	.003 – .007
Tool Steel	50 – 100	.0005 – .002	.002 – .003	.003 – .007
Wood	125 – 300	.0005 – .002	.002 – .003	.003 – .007
Zinc	250 – 300	.0005 – .002	.002 – .003	.003 – .007

Speed and Feed figures suggested should be considered starting points only.

Speed: Factors affecting optimum Drill speeds depend on: Depth of hole, hardness of material, coolant, drill machine type, hole finish, and hole location.

Feed: Factors affecting feed rates are drill diameters, machinability of material, and depth of hole. Small drills, harder materials, and hole depths in excess of 3 – 4 times diameter require adjustment to suggested drill feed rates.

WARNING: Rotary tools can shatter under improper or severe use. Persons in the vicinity of their use should be instructed to wear safety equipment.



Climb Milling

In conventional milling, the cutter revolves opposite to the direction of table feed. Therefore the width of the chip starts at zero and increases to a maximum at the end of the cut. This can lead to accelerated tool wear under some conditions - conventional milling is recommended for hot rolled steel, surface hardened materials and steels with a surface scale. In climb milling, the cutter revolves in the same direction as the table feed. The tooth meets the work at the top of the cut, producing the thickest part of the chip first. In horizontal applications the resultant force created by climb milling can act as a clamping force, acting toward the machine table. It is important to make sure that the machine tool has no leadscrew backlash. Normally climb milling improves product surface finish and increases tool life.

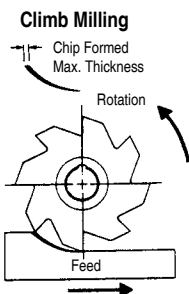

Conventional Milling

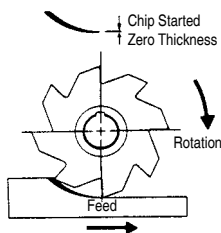

Advantages of Climb Milling

Longer Tool Life: Since the chips produced are deposited behind the cutter, tool life can be substantially increased.

Ease of Fixturing: Climb milling exerts a downward clamping force on the workpiece and not an upward force as in conventional milling, which results in simplified fixturing.

Improved Surface Finish: Since the chips are not carried by the cutter, less likelihood of marring the machined surface.

Lower Power Requirements: A higher rake angle can be utilized, lowering power consumption.

Better Chip Evacuation: Easier and faster chip removal since chips are deposited behind the cutter.

Speeds and Feeds

Modern milling cutters capable of operating at higher feeds and speeds, and moving more cubic inches of metal per minute, require greater machine rigidity and more power. Therefore it is important to determine that enough power is available to handle the desired depth and width of cut at the higher feeds and speeds.

- T= Number of teeth in cutter
- D= Cutter diameter in inches
- RPM= Revolutions per minute
- SFM= Surface feet per minute
- F= Feed in inches per minute
- f= Feed per tooth in inches
- W= Width of cut
- d= Depth of cut
- HP= Motor horsepower
- C= Machinability constant

To Find	Having	Formula
Speed of Cutter in Surface Feet Per Minute (SFM)	Diameter of Cutter and Revolutions Per Minute D + RPM	$SFM = \frac{3.1416 \times D \times RPM}{12}$ or $SFM = D \times .26 \times RPM$
Revolutions Per Minute (RPM)	Surface Feet Per Minute and Diameter of Cutter SFM + D	$RPM = \frac{SFM \times 12}{3.1416 \times D}$ $RPM = \frac{SFM \times 3.82}{D}$
Feed in Inches Per Minute (F)	Feed Per Tooth, Number of Teeth and Revolutions Per Minute f + T + RPM	$F = f \times T \times RPM$
Feed per Tooth in Inches (FPT) or (f)	Feed in Inches Per Minute, Number of Teeth Revolutions F + T + RPM	$f = \frac{F}{T \times RPM}$
Horsepower (HP)	Depth of cut, Width of Cut, Feed in Inches Per Minute and Machinability Constant d + W + F + C	$HP = \frac{d \times W \times F}{C}$ $HP = \frac{d \times W \times T \times f \times RPM}{C}$

Machinability constant values for various materials are based on removing one cubic inch of metal per minute per horsepower with 60% power efficiency at the spindle nose and a 25% allowance for cutter dulling.

Aluminum, Magnesium, Dural	4.0 plus
Brass	2.5
Soft Bronze, Copper	2.0
Cast Iron	1.5
Steel up to 150 Brinell, Malleable Iron	0.75
Steel, 300 Brinell, Hard Bronze	0.6
Steel, 400 Brinell	0.5

KEO-PAK



What is a KEO-PAK?

KEO Cutters now offers the individualized packaging of tools normally sold in quantities of 3, 6 and 12. A convenient easy to open package that is designed to provide individual protection for the tool in a multi-pack. The new style packaging can be used for several different purposes such as vending machines and will prevent the need for repacking. Begin ordering KEO-PAK today!

For pricing see our pricing guide or call Customer Service at 1.888.390.2050 for more details.



KEO CUTTERS

25040 Easy Street, Warren, Michigan 48089-400

Toll-Free (888) 390-2050 • Tel (586) 771-2050

Toll-Free Fax (888) 771-2062 • Fax (586) 771-2062

www.KEOCUTTERS.com

EMAIL: support@keocutters.com

ORDER REQUEST: sales@keocutters.com

SPECIALTY QUOTES: quotes@keocutters.com

