



CA6535 PR1535

Milling of
Heat Resistant Alloy

New Grades

for a variety of workpiece
materials and applications

- **CA6535** (CVD)
for Ni-base heat resistant alloy and
martensitic stainless steel
- **PR1535** (PVD)
for titanium alloy and precipitation
hardened stainless steel



2 New Grades for Extending Tool Life

when machining heat resistant alloy and difficult-to-cut materials

CA6535 (CVD)

for Ni-base heat resistant alloy and martensitic stainless steel

PR1535 (PVD)

for titanium alloy and precipitation hardened stainless steel

NEW New grades for difficult-to-cut material

- Stable cutting prevents insert fracturing
- Good for high efficiency machining



CA6535

- For Ni-base heat resistant alloy and martensitic stainless steel
- High heat resistance and wear resistance with CVD coating
- Improved stability due to thin film coating technology

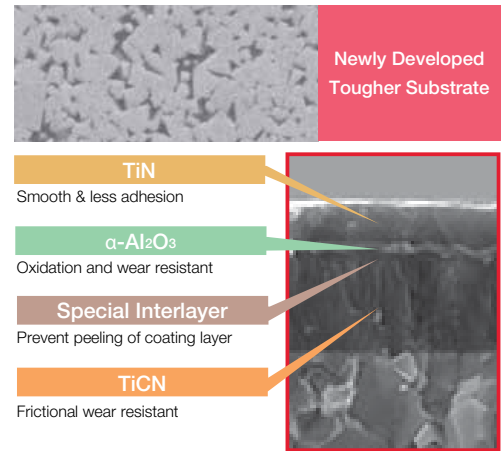

PR1535

- For titanium alloy and precipitation hardened stainless steel
- Stabilized milling operation and long tool life with Kyocera's MEGACOAT NANO coating technology
- Improved stability due to thin film coating technology

MEGACOAT Layer structure

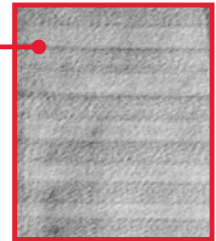

Tool Life Comparison

- Ni-base Heat Resistant Alloy

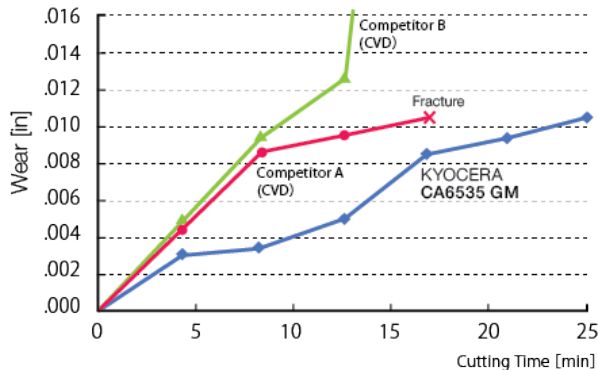

1st recommendation GM chipbreaker

- Martensitic Stainless Steel

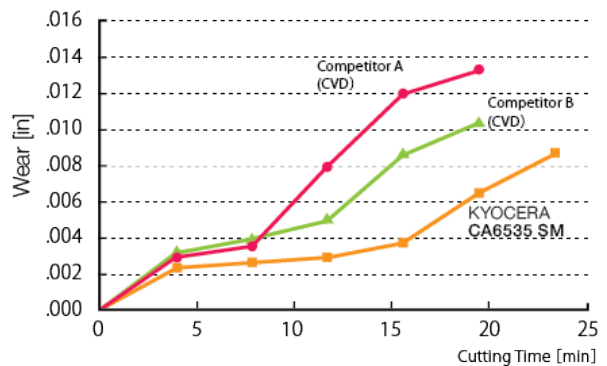

1st recommendation SM chipbreaker

RAD-8 (MRW)

- 1 **Economical 8-edge insert**
- 2 **Combined sharpness & cutting edge strength**
Improved edge strength due to obtuse edge
- 3 **Helical cutting edge design with maximum axial rake 12°**
Lower cutting forces equivalent to positive inserts
- 4 **Flat Lock Structure to hold insert firmly**



Applicable Insert

Insert	Description	Dimension (inch)					MEGACOAT NANO			CVD Coating
		ØA	T	Ød	W	rε	PR1535	PR1525	PR1510	CA6535
General Purpose	ROMU 1204M0ER-GM	0.472	0.187	0.181	0.465	0.236	●	●	●	●
	1605M0ER-GM	0.630	0.216	0.244	0.622	0.315	●	●	●	●
Low Cutting Force	ROMU 1204M0ER-SM	0.472	0.187	0.181	0.465	0.236	●	●		●
	1605M0ER-SM	0.630	0.216	0.244	0.622	0.315	●	●		●
Tough Edge (Heavy Milling)	ROMU 1204M0ER-GH	0.472	0.187	0.181	0.465	0.236		●	●	
	1605M0ER-GH	0.630	0.216	0.244	0.622	0.315		●	●	

Recommended Cutting Conditions

Chipbreaker	Workpiece Material	fz (ipt) feed	(Vc: sfm) Recommended Insert Grade			
			MEGACOAT NANO			CVD
			PR1535	PR1525	PR1510	CA6535
GM	Carbon Steel SxxC	0.004- 0.008 -0.012	-	★ 400- 600 -825	-	-
	Alloy Steel SCM etc	0.004- 0.008 -0.012	-	★ 325- 525 -725	-	-
	Mold Steel SKD/NAK etc	0.004- 0.006 -0.010	-	★ 250- 450 -600	-	-
	Austenitic Stainless Steel SUS304	0.004- 0.006 -0.008	-	☆ 325- 525 -650	-	-
	Martensitic Stainless Steel SUS403	0.004- 0.006 -0.008	☆ 500- 650 -825	-	-	-
	Precipitation Hardened Stainless Steel SUS630 etc	0.004- 0.006 -0.008	★ 300- 400 -500	-	-	-
	Gray Cast Iron FC	0.004- 0.008 -0.012	-	-	★ 400- 600 -825	-
	Nodular Cast Iron FCD	0.004- 0.006 -0.010	-	-	★ 325- 500 -650	-
	Ni	0.004- 0.005 -0.006	-	-	-	★ 75- 100 -150
	Titanium Alloys Ti-6Al-4V	0.004- 0.005 -0.006	-	-	☆ 100- 150 -225	-
SM	Carbon Steel SxxC	0.002- 0.006 -0.008	-	☆ 400- 600 -825	-	-
	Alloy Steel SCM etc	0.002- 0.006 -0.008	-	☆ 325- 525 -725	-	-
	Mold Steel SKD/NAK etc	0.002- 0.005 -0.008	-	☆ 250- 450 -600	-	-
	Austenitic Stainless Steel SUS304 etc	0.002- 0.005 -0.008	★ 325- 525 -650	-	-	-
	Martensitic Stainless Steel SUS403 etc	0.002- 0.005 -0.008	-	-	-	★ 600- 775 -975
	Precipitation Hardened Stainless Steel SUS630 etc	0.002- 0.005 -0.008	☆ 300- 400 -500	-	-	-
	Ni	0.002- 0.004 -0.006	-	-	-	☆ 75- 100 -150
	Titanium Alloys Ti-6Al-4V	0.002- 0.004 -0.006	★ 125- 200 -825	-	-	-
	Carbon Steel SxxC	0.006- 0.012 -0.014	-	☆ 400- 600 -825	-	-
	Alloy Steel SCM etc	0.006- 0.012 -0.014	-	☆ 325- 525 -725	-	-
GH	Mold Steel SKD/NAK etc	0.006- 0.008 -0.012	-	☆ 250- 450 -600	-	-
	Gray Cast Iron FC	0.006- 0.012 -0.014	-	-	☆ 400- 600 -825	-
	Nodular Cast Iron FCD	0.006- 0.008 -0.012	-	-	☆ 325- 500 -650	-

※ The figure in bold font is center value of the recommended cutting conditions. Adjust the cutting speed and the feed rate within the above conditions according to the actual machining situation.

※ Machining with coolant is recommended for Ni-base Heat Resistant Alloy and Titanium Alloy

※ Recommended feed rate is the reference value when ap is rε/2 (3mm for ROMU12, 4mm for ROMU16).





★:1st Recommendation
☆:2nd Recommendation

M-Four (MEW)

- Form Improves Function**
Kyocera's unique insert-forming technology reduces cutting forces equivalent to positive inserts
- MEGACOAT NANO**
Extended tool life by new MEGACOAT NANO insert coating technology reduces cutting costs



Applicable Insert

Insert	Description	rE	MEGACOAT NANO			CVD Coating
			PR1535	PR1525	PR1510	CA6535
 General Purpose	LOMU 100404ER-GM	0.016	●	●	●	●
	100408ER-GM	0.031	●	●	●	●
	100412ER-GM	0.047	○	●	●	○
 Low Cutting Forces	LOMU 100408ER-SM	0.031	●	●	●	●
 General Purpose	LOMU 150504ER-GM	0.016	●	●	●	●
	150508ER-GM	0.031	●	●	●	●
	150512ER-GM	0.047	○	●	●	○
 Low Cutting Forces	LOMU 150508ER-SM	0.031	●	●	●	○

● Stock Standard | ○ World Express

Recommended Cutting Conditions

Chipbreaker	Workpiece Material	fz (pt) feed		(Vc: sfm) Recommended Insert Grade			
		Toolholder Descriptions		MEGACOAT NANO			CVD
		MEW16-MEW18	MEW65-MEW50 MEW032R-MEW0250R	PR1535	PR1525	PR1510	CA6535
GM	Carbon Steel SxxC	0.002- 0.004 -0.008	0.003- 0.006 -0.010	-	400- 600 -825	-	-
	Alloy Steel SCM etc	0.002- 0.004 -0.006	0.003- 0.006 -0.008	-	325- 525 -725	-	-
	Mold Steel SKD/NAK etc	0.002- 0.003 -0.005	0.003- 0.005 -0.008	-	250- 450 -600	-	-
	Austenitic Stainless Steel SUS1004 etc	0.002- 0.003 -0.005	0.003- 0.005 -0.006	325- 525 -650	325- 525 -650	-	-
	Martensitic Stainless Steel SUS403 etc	0.002- 0.003 -0.005	0.003- 0.005 -0.008	500- 650 -825	-	-	600- 800 -1000
	Precipitation Hardened Stainless Steel SUS6100 etc	0.002- 0.003 -0.005	0.003- 0.005 -0.008	1000- 400 -500	-	-	-
	Gray Cast Iron FC	0.002- 0.004 -0.007	0.003- 0.007 -0.010	-	-	400- 600 -825	-
	Nodular Cast Iron FCD	0.002- 0.003 -0.005	0.003- 0.006 -0.008	-	-	325- 500 -650	-
	Ni	0.002- 0.003 -0.005	0.003- 0.005 -0.006	65- 100 -165	-	-	65- 100 -165
Titanium Alloys Ti-6Al-4V	0.002- 0.003 -0.005	0.003- 0.006 -0.008	125- 200 -825	-	100- 165 -230	-	
SM	Carbon Steel SxxC	0.002- 0.004 -0.007	0.003- 0.006 -0.008	-	400- 600 -825	-	-
	Alloy Steel SCM etc	0.002- 0.003 -0.005	0.003- 0.005 -0.007	-	325- 525 -725	-	-
	Mold Steel SKD/NAK etc	0.002- 0.003 -0.005	0.003- 0.004 -0.006	-	250- 450 -600	-	-
	Austenitic Stainless Steel SUS1004 etc	0.002- 0.003 -0.005	0.003- 0.004 -0.006	325- 525 -650	325- 525 -650	-	-
	Martensitic Stainless Steel SUS403 etc	0.002- 0.003 -0.005	0.003- 0.004 -0.006	500- 650 -825	-	-	600- 800 -1000
	Precipitation Hardened Stainless Steel SUS6100 etc	0.002- 0.003 -0.005	0.003- 0.004 -0.006	300- 400 -500	-	-	-
	Ni	0.002- 0.003 -0.004	0.003- 0.004 -0.005	65- 100 -165	-	-	65- 100 -165
	Titanium Alloys Ti-6Al-4V	0.002- 0.003 -0.005	0.003- 0.005 -0.007	125- 200 -825	-	100- 165 -230	-

※ The figure in bold font is center value of the recommended cutting conditions. Adjust the cutting speed and the feed rate within the above conditions according to the actual machining situation.

※ Machining with coolant is recommended for Ni-base Heat Resistant Alloy and Titanium Alloy



★:1st Recommendation
☆:2nd Recommendation

M-Six (MFWN)



- 1 **Economical 6-Edge insert**
Low cutting forces with less chattering
- 2 **MEGACOAT NANO**
Extended tool life by new MEGACOAT NANO insert coating technology reduces cutting costs

Applicable Insert

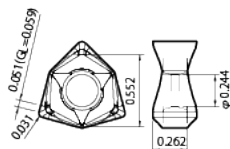
Insert		Description	MEGACOAT NANO			CVD Coating
			PR1535	PR1525	PR1510	CA6535
 General Purpose  Low Cutting Forces  Surface-Finish Oriented (High Precision)		WNMU 080608EN-GM	●	●	●	●
		080608EN-SM	●	●	●	●
		WNEU 080608EN-GL	○	●	●	○

● Stock Standard | ○ World Express

Recommended Cutting Conditions

Chipbreaker	Workpiece Material	fz (ipt) feed	(Vc: sfm) Recommended Insert Grade			
			MEGACOAT NANO			CVD
			PR1535	PR1525	PR1510	CA6535
GM	Carbon Steel SxxC	0.004- 0.008 -0.012	-	★400- 600 -825	-	-
	Alloy Steel SCM etc	0.004- 0.008 -0.012	-	★325- 525 -725	-	-
	Mold Steel SKD/NAK etc	0.004- 0.006 -0.010	-	★250- 450 -600	-	-
	Austenitic Stainless Steel SUS304 etc	0.004- 0.006 -0.010	☆325- 500 -650	-	-	-
	Martensitic Stainless Steel SUS403 etc	0.004- 0.006 -0.010	-	-	-	☆600- 775 -975
	Precipitation Hardened Stainless Steel SUS630 etc	0.004- 0.006 -0.010	★300- 400 -500	-	-	-
	Gray Cast Iron FC	0.004- 0.008 -0.012	-	-	★400- 600 -825	-
	Nodular Cast Iron FCD	0.004- 0.005 -0.010	-	-	★325- 500 -650	-
	Ni	0.004- 0.005 -0.008	-	-	-	★75- 100 -150
SM	Carbon Steel SxxC	0.002- 0.005 -0.008	-	☆400- 600 -825	-	-
	Alloy Steel SCM etc	0.002- 0.005 -0.008	-	☆325- 525 -725	-	-
	Mold Steel SKD/NAK etc	0.002- 0.003 -0.006	-	☆250- 450 -600	-	-
	Austenitic Stainless Steel SUS304 etc	0.002- 0.005 -0.008	★325- 500 -650	-	-	-
	Martensitic Stainless Steel SUS403 etc	0.002- 0.005 -0.008	-	-	-	★600- 775 -975
	Precipitation Hardened Stainless Steel SUS630 etc	0.002- 0.005 -0.008	☆300- 400 -500	-	-	-
	Gray Cast Iron FC	0.002- 0.005 -0.008	-	-	400- 600 -825	-
	Nodular Cast Iron FCD	0.002- 0.003 -0.006	-	-	325- 500 -650	-
	Ni	0.002- 0.004 -0.006	-	-	-	☆75- 100 -150
Titanium Alloys Ti-6Al-4V	0.002- 0.003 -0.006	★125- 200 -825	-	-	-	
GL	Carbon Steel SxxC	0.002- 0.005 -0.008	-	400- 600 -825	-	-
	Alloy Steel SCM etc	0.002- 0.005 -0.008	-	325- 525 -725	-	-
	Mold Steel SKD/NAK etc	0.002- 0.003 -0.006	-	250- 450 -600	-	-
	Austenitic Stainless Steel SUS304 etc	0.002- 0.005 -0.008	325- 500 -650	-	-	-
	Martensitic Stainless Steel SUS403 etc	0.002- 0.005 -0.008	-	-	-	600- 775 -975
	Precipitation Hardened Stainless Steel SUS630 etc	0.002- 0.005 -0.008	300- 400 -500	-	-	-
	Gray Cast Iron FC	0.002- 0.005 -0.008	-	-	400- 600 -825	-
	Nodular Cast Iron FCD	0.002- 0.003 -0.006	-	-	325- 500 -650	-
	Ni	0.002- 0.004 -0.006	-	-	-	75- 100 -150
Titanium Alloys Ti-6Al-4V	0.002- 0.003 -0.006	125- 200 -825	-	-	-	

※ The figure in bold font is center value of the recommended cutting conditions. Adjust the cutting speed and the feed rate within the above conditions according to the actual machining situation.

※ Machining with coolant is recommended for Ni-base Heat Resistant Alloy and Titanium Alloy

★:1st Recommendation
☆:2nd Recommendation

MFPN

- 1 **10-edge Pentagonal Inserts**
for roughing and general-purpose face milling
- 2 **Low Cutting Forces**
with helical cutting-edge design
- 3 **Fractures Suppressed**
by double-edge design



Applicable Insert

Insert	Description	Dimension (in)					MEGACOAT NANO			MEGACOAT		CVD
		A	T	Ød	X	Z	PR1535	PR1525	PR1510	PR1225	PR1210	CA6535
General Purpose	PNMU 1205ANER-GM	0.704	0.219	0.244	0.079	0.079	●	●	●	●	●	●
Low Cutting Force							●	●	●	●	●	●
High Precision (Finishing)	PNEU 1205ANER-GL	0.689	0.219		0.106	0.106	○	●	●	●	●	○

NEW

NEW

● Stock Standard | ○ World Express

Recommended Cutting Conditions

Chipbreaker	Workpiece Material	fz (ipt) feed	(Vc: sfm) Recommended Insert Grade			
			MEGACOAT NANO			CVD
			PR1535	PR1525	PR1510	CA6535
GM	Carbon Steel SxxC	0.004- 0.008 -0.016	-	★ 400- 600 -825	-	-
	Alloy Steel SCM etc	0.004- 0.008 -0.016	-	★ 325- 525 -725	-	-
	Mold Steel SKD/NAK etc	0.004- 0.008 -0.014	-	★ 250- 450 -600	-	-
	Austenitic Stainless Steel SUS304 etc	0.004- 0.008 -0.016	☆ 325- 500 -650	-	-	-
	Martensitic Stainless Steel SUS403 etc	0.004- 0.008 -0.016	-	-	-	☆ 600- 775 -975
	Precipitation Hardened Stainless Steel SUS630 etc	0.004- 0.008 -0.012	★ 300- 400 -500	-	-	-
	Gray Cast Iron FC	0.004- 0.008 -0.016	-	-	★ 400- 600 -825	-
	Nodular Cast Iron FCD	0.004- 0.008 -0.014	-	-	★ 325- 500 -650	-
	Ni	0.004- 0.005 -0.008	-	-	-	★ 75- 100 -150
SM	Carbon Steel SxxC	0.002- 0.005 -0.010	-	☆ 400- 600 -825	-	-
	Alloy Steel SCM etc	0.002- 0.005 -0.010	-	☆ 325- 525 -725	-	-
	Mold Steel SKD/NAK etc	0.002- 0.004 -0.008	-	☆ 250- 450 -600	-	-
	Austenitic Stainless Steel SUS304 etc	0.002- 0.005 -0.010	☆ 325- 500 -650	-	-	-
	Martensitic Stainless Steel SUS403 etc	0.002- 0.005 -0.010	-	-	-	★ 600- 775 -975
	Precipitation Hardened Stainless Steel SUS630 etc	0.002- 0.005 -0.010	☆ 300- 400 -500	-	-	-
	Gray Cast Iron FC	0.002- 0.005 -0.010	-	-	★ 400- 600 -825	-
	Nodular Cast Iron FCD	0.002- 0.004 -0.008	-	-	★ 325- 500 -650	-
	Ni	0.002- 0.004 -0.006	-	-	-	★ 75- 100 -150
Titanium Alloys Ti-6Al-4V	0.002- 0.003 -0.006	★ 125- 200 -825	-	-	-	
GL	Carbon Steel SxxC	0.002- 0.005 -0.010	-	★ 400- 600 -825	-	-
	Alloy Steel SCM etc	0.002- 0.005 -0.010	-	★ 325- 525 -725	-	-
	Mold Steel SKD/NAK etc	0.002- 0.004 -0.008	-	★ 250- 450 -600	-	-
	Austenitic Stainless Steel SUS304 etc	0.002- 0.005 -0.010	★ 325- 500 -650	-	-	-
	Martensitic Stainless Steel SUS403 etc	0.002- 0.005 -0.010	-	-	-	★ 600- 775 -975
	Precipitation Hardened Stainless Steel SUS630 etc	0.002- 0.005 -0.010	★ 300- 400 -500	-	-	-
	Gray Cast Iron FC	0.002- 0.005 -0.010	-	-	★ 400- 600 -825	-
	Nodular Cast Iron FCD	0.002- 0.004 -0.008	-	-	★ 325- 500 -650	-
	Ni	0.002- 0.004 -0.006	-	-	-	★ 75- 100 -150
Titanium Alloys Ti-6Al-4V	0.002- 0.003 -0.006	★ 125- 200 -825	-	-	-	

※ The figure in bold font is center value of the recommended cutting conditions. Adjust the cutting speed and the feed rate within the above conditions according to the actual machining situation.

※ Machining with coolant is recommended for Ni-base Heat Resistant Alloy and Titanium Alloy



★:1st Recommendation
☆:2nd Recommendation

MEC

- 1 Low Cutting Force**
with sharp cutting performance
- 2 Perfect 90° Shoulders**
with smooth surface of shoulder wall
- 3 Extensive Grade Lineup**
Applicable to a wide range of workpiece materials, such as steel, stainless steel, cast iron, and aluminum

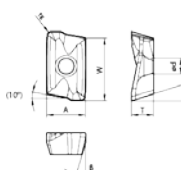

Applicable Insert

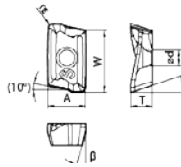
Insert	Description	Dimension (in)					Angle (°)		MEGACOAT NANO			CVD Coating
		A	T	Ød	W	r _ε	α	β	PR1535	PR1525	PR1510	CA6535
 	BDMT 11T302ER-JT	0.264	0.150	0.110	0.433	0.008	18	13	○	●	●	○
	11T304ER-JT					●			●	●	●	
	11T308ER-JT					●			●	●	●	
	11T312ER-JT					○			●	●	○	
	11T316ER-JT					○			●	●	●	
	11T320ER-JT					○			●	●	○	
	11T324ER-JT					○			●	●	○	
	11T331ER-JT					○			●	●	○	
	BDMT 170404ER-JT	0.378	0.193	0.173	0.669	0.016	18	13	●	●	●	●
	170408ER-JT					●			●	●	●	
	170412ER-JT					○			●	●	○	
	170416ER-JT					●			●	●	●	
	170420ER-JT					○			●	●	○	
	170424ER-JT					○			●	●	○	
170431ER-JT	●					●			●	●		
170440ER-JT	○	●	●	○								
 	BDMT 11T302ER-JS	0.264	0.150	0.110	0.433	0.008	18	13	○	●	○	○
	11T304ER-JS					●			●	○	●	
	11T308ER-JS					●			●	○	●	
	BDMT 170404ER-JS	0.378	0.193	0.173	0.669	0.016	18	13	●	●	○	○
	170408ER-JS					●			●	○	●	

NEW

NEW

Recommended Cutting Conditions

● Stock Standard | ○ World Express

Chipbreaker	Workpiece Material	fz (ipt) feed		(Vc: sfm) Recommended Insert Grade			
		Toolholder Descriptions		MEGACOAT NANO			CVD
		MEC0500-MEC0750	MEC1000-MEC1500 MEC1500R-MEC4000R	PR1535	PR1525	PR1510	CA6535
JT	Carbon Steel S _x C	0.002- 0.004 -0.006	0.003- 0.006 -0.010	-	400- 600 -825	-	-
	Alloy Steel SCM etc	0.002- 0.004 -0.005	0.003- 0.006 -0.008	-	325- 525 -725	-	-
	Mold Steel SKD/NAK etc	0.002- 0.003 -0.004	0.003- 0.005 -0.008	-	250- 450 -600	-	-
	Austenitic Stainless Steel SUS304 etc	0.002- 0.003 -0.004	0.003- 0.005 -0.006	325- 650 -650	325- 525 -725	-	-
	Martensitic Stainless Steel SUS403 etc	0.002- 0.003 -0.004	0.003- 0.005 -0.008	500- 650 -825	-	-	600- 775 -975
	Precipitation Hardened Stainless Steel SUS630 etc	0.002- 0.003 -0.004	0.003- 0.005 -0.008	300- 400 -500	-	-	-
	Gray Cast Iron FC	0.002- 0.004 -0.006	0.003- 0.007 -0.010	-	-	400- 600 -825	-
	Nodular Cast Iron FCD	0.002- 0.003 -0.004	0.003- 0.006 -0.008	-	-	325- 500 -650	-
	Ni	0.002- 0.003 -0.004	0.003- 0.005 -0.006	75- 100 -150	-	-	75- 100 -150
	Titanium Alloys Ti-6Al-4V	0.002- 0.003 -0.004	0.003- 0.006 -0.008	125- 200 -250	-	100- 150 -225	-
JS	Carbon Steel S _x C	0.002- 0.004 -0.005	0.003- 0.006 -0.007	-	400- 600 -825	-	-
	Alloy Steel SCM etc	0.002- 0.003 -0.004	0.003- 0.005 -0.006	-	325- 525 -725	-	-
	Mold Steel SKD/NAK etc	0.002- 0.003 -0.004	0.003- 0.004 -0.005	-	250- 450 -600	-	-
	Austenitic Stainless Steel SUS304 etc	0.002- 0.003 -0.004	0.003- 0.004 -0.005	325- 525 -650	325- 525 -650	-	-
	Martensitic Stainless Steel SUS403 etc	0.002- 0.003 -0.004	0.003- 0.004 -0.005	500- 650 -825	-	-	600- 775 -975
	Precipitation Hardened Stainless Steel SUS630 etc	0.002- 0.003 -0.004	0.003- 0.004 -0.005	300- 400 -500	-	-	-
	Ni	0.002- 0.003 -0.004	0.003- 0.004 -0.005	75- 100 -150	-	-	75- 100 -150
	Titanium Alloys Ti-6Al-4V	0.002- 0.003 -0.004	0.003- 0.004 -0.005	125- 200 -250	-	-	-

※ The figure in bold font is center value of the recommended cutting conditions. Adjust the cutting speed and the feed rate within the above conditions according to the actual machining situation.

※ Machining with coolant is recommended for Ni-base Heat Resistant Alloy and Titanium Alloy

★:1st Recommendation
☆:2nd Recommendation

Case Studies

MRW

12Cr Steel	
<ul style="list-style-type: none"> Turbine Blade Vc=875sfm fz=0.006ipt ap=0.020-0.039" ae=max1.378" Dry MRW050R-12-6T-M (6 inserts) ROMU1204M0ER-SM (CA6535) 	1.2 times the machining efficiency Economical double-faced insert
CA6535	Stable Machining
Competitor A (Positive Cutter)	Unstable Machining
MRW improved machining efficiency 1.2 times with same tool life compared to Competitor A. MRW has a cost advantage due to double sided inserts.	
(User Evaluation)	

12Cr Steel	
<ul style="list-style-type: none"> Turbine Blade Vc=825sfm fz=0.006ipt ap=0.079" ae=0.197-1.181" Wet MRW050R-12-5T-M (6 inserts) ROMU1204M0ER-SM (CA6535) 	Same or longer tool life Economical double-faced insert
CA6535	Stable, Available for Further Machining
Competitor B (Positive Cutter)	Unstable Machining
MRW showed less damage on the cutting edge and reduced cutting noise. MRW has equal or longer tool life and cost advantage due to double-sided inserts.	
(User Evaluation)	

MFPN

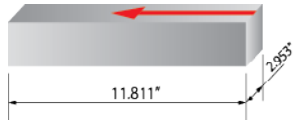
Ti-6Al-4V	
<ul style="list-style-type: none"> Chemical Plant Part Vc=85sfm fz=0.018ipt ap=0.012" Wet MFPN45160R-8T (8 inserts) PNUMU1205ANER-SM (PR1535) 	
PR1535	4 Surfaces/Corner or Cutting Edge
Competitor D (Positive Cutter)	4 Surfaces/Corner or Cutting Edge
MFPN processed the same number of output as Competitor D. Edge condition was still possible to extend tool life. MFPN has cost advantage due to 10-edge use compared with Competitor D (4-edge)	
(User Evaluation)	

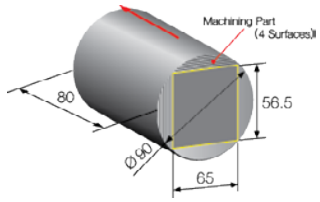
Heat Resistant Alloy	
<ul style="list-style-type: none"> Turbine Blade Vc=525sfm fz=0.005ipt ap=0.079" Wet MFPN45100R-8T (8 inserts) PNUMU1205ANER-GM (CA6535) 	
CA6535	3.5 Surfaces/Corner or Cutting Edge
Competitor L (Positive Cutter)	2.5 Surfaces/Corner or Cutting Edge
MFPN achieved 1.4 times longer tool life compared with Competitor E with stable machining.	
(User Evaluation)	

MFWN

SUS316L	
<ul style="list-style-type: none"> Energy Plant Part Vc=500sfm fz=0.006ipt ap=0.118-0.197" Wet MFWN90160R-8T (8 inserts) WNMU080608EN-GM (PR1535) 	
PR1535	1 Surface/Corner or Cutting Edge
Competitor C (Negative Cutter)	1 Surface/Corner or Cutting Edge
MFWN improved cutting edge condition and finished surface compared with Competitor C.	
(User Evaluation)	



Kyocera Industrial Ceramics Corp. Cutting Tool Division

100 Industrial Park Road ■ Hendersonville, NC 28792

Email: cuttingtools@kyocera.com

Website: www.kyocera.com/cuttingtools

Distributor Website: <http://mykicc.kyocera.com>

Customer Service: 800.823.7284 - Option 1

Technical Support: 800.823.7284 - Option 2

connect with us

