



# High Performance End Mills

for Aluminum and Exotic Metals





LMT Onsrud has provided tooling to the aerospace, medical and energy industries for over 60 years. As materials have changed so have our tool designs... from high-speed steel used in hand routing of aluminum sheet to sophisticated coated solid carbide and diamond for today's composite and exotic metal materials.

The manufacturing facility in Waukegan Illinois, which houses the latest CNC grinding equipment, and in house coating can provide special tooling with fast response to meet customer demands. LMT Onsrud enhances state-of-the-art manufacturing with highly trained professional technicians who are available to evaluate your cutting tool needs.

the  
**ONSRUD**  
a d v a n t a g e

When you want the right tool for the job, contact **The Performance Team** at LMT Onsrud.

























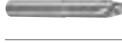

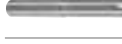















- "C" Flute For Aluminum
- Aluminum 2 Flute
- Aluminum 3 Flute/ Coolant Through
- Aluminum Rougher/ Coolant Through
- Exotic Metal 4 Flute Rougher
- Exotic Metal 5 Flute
- Exotic Metal 7 Flute
- Exotic Metal Finisher

# TABLE of CONTENTS

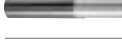



















Technical Data for Aluminum Series	4, 21, 30	Technical Series for Routing Tools	61
Aluminum	4 - 34	Routing Tools	61 - 64
Technical Data for Exotic Metal Series	36, 42, 48, 55	Quote Request Forms	65
Exotic Metals & Stainless Steel	35 - 60	Terms and Conditions	69

## TABLE of CONTENTS by SERIES







### ALUMINUM

	<b>AFS - 2</b> Aluminum Standard Length 2 Flute	5		<b>AFS - 3</b> Aluminum Standard Length 3 Flute	13
	<b>AFM - 2</b> Aluminum Medium Length 2 Flute	6		<b>AFM - 3</b> Aluminum Medium Length 3 Flute	14
	<b>AFL - 2</b> Aluminum Long Length 2 Flute	7		<b>AFL - 3</b> Aluminum Long Length 3 Flute	15
	<b>AFX - 2</b> Aluminum Extra Long Length 2 Flute	8		<b>AFX - 3</b> Aluminum Extra Long Length 3 Flute	16
	<b>AFNS - 2</b> Aluminum Standard Length 2 Flute Necked	9		<b>AFNS - 3</b> Aluminum Standard Length 3 Flute Necked	17
	<b>AFNM - 2</b> Aluminum Medium Length 2 Flute Necked	10		<b>AFNM - 3</b> Aluminum Medium Length 3 Flute Necked	18
	<b>AFNL - 2</b> Aluminum Long Length 2 Flute Necked	11		<b>AFNL - 3</b> Aluminum Long Length 3 Flute Necked	19
	<b>AFNX - 2</b> Aluminum Extra Long Length 2 Flute Necked	12		<b>AFNX - 3</b> Aluminum Extra Long Length 3 Flute Necked	20
	<b>AFCNS - 2</b> Aluminum Coolant Through Standard Length 2 Flute Necked	22		<b>AFCNS - 3</b> Aluminum Coolant Through Standard Length 3 Flute Necked	26
	<b>AFCNM - 2</b> Aluminum Coolant Through Medium Length 2 Flute Necked	23		<b>AFCNM - 3</b> Aluminum Coolant Through Medium Length 3 Flute Necked	27
	<b>AFCNL - 2</b> Aluminum Coolant Through Long Length 2 Flute Necked	24		<b>AFCNL - 3</b> Aluminum Coolant Through Long Length 3 Flute Necked	28
	<b>AFCNX - 2</b> Aluminum Coolant Through Extra Long Length 2 Flute Necked	25		<b>AFCNX - 3</b> Aluminum Coolant Through Extra Long Length 3 Flute Necked	29
	<b>ARS - 2 NEW</b> Aluminum Rougher Standard Length 2 Flute	31		<b>ARS - 3 NEW</b> Aluminum Rougher Standard Length 3 Flute	32
	<b>ARNS - 2 NEW</b> Aluminum Rougher Standard Length 2 Flute Necked	31		<b>ARNS - 3 NEW</b> Aluminum Rougher Standard Length 3 Flute Necked	32
	<b>ARNM - 2 NEW</b> Aluminum Rougher Medium Length 2 Flute Necked	31		<b>ARNM - 3 NEW</b> Aluminum Rougher Medium Length 3 Flute Necked	32
	<b>ARNL - 2 NEW</b> Aluminum Rougher Long Length 2 Flute Necked	31		<b>ARNL - 3 NEW</b> Aluminum Rougher Long Length 3 Flute Necked	32
	<b>ARCS - 2 NEW</b> Aluminum Rougher Coolant Through Standard Length 2 Flute	33		<b>ARCS - 3 NEW</b> Aluminum Rougher Coolant Through Standard Length 3 Flute	34
	<b>ARCNS - 2 NEW</b> Aluminum Rougher Coolant Through Standard Length 2 Flute Necked	33		<b>ARCNS - 3 NEW</b> Aluminum Rougher Coolant Through Standard Length 3 Flute Necked	34
	<b>ARCNM - 2 NEW</b> Aluminum Rougher Coolant Through Medium Length 2 Flute Necked	33		<b>ARCNM - 3 NEW</b> Aluminum Rougher Coolant Through Medium Length 3 Flute Necked	34
	<b>ARCNL - 2 NEW</b> Aluminum Rougher Coolant Through Long Length 2 Flute Necked	33		<b>ARCNL - 3 NEW</b> Aluminum Rougher Coolant Through Long Length 3 Flute Necked	34

## EXOTIC METALS & STAINLESS STEEL

	<b>TVS - 4</b> Exotic Metals Variable Index Standard Length 4 Flute	37
	<b>TVM - 4</b> Exotic Metals Variable Index Medium Length 4 Flute	38
	<b>TVNS - 4</b> Exotic Metals Variable Index Standard Length 4 Flute Necked	39
	<b>TVNM - 4</b> Exotic Metals Variable Index Medium Length 4 Flute Necked	40
	<b>TVNL - 4</b> Exotic Metals Variable Index Long Length 4 Flute Necked	41
	<b>TVS - 5</b> Exotic Metals Variable Index Standard Length 5 Flute	43
	<b>TVM - 5</b> Exotic Metals Variable Index Medium Length 5 Flute	44
	<b>TVNS - 5</b> Exotic Metals Variable Index Standard Length 5 Flute Necked	45
	<b>TVNM - 5</b> Exotic Metals Variable Index Medium Length 5 Flute Necked	46
	<b>TVNL - 5</b> Exotic Metals Variable Index Long Length 5 Flute Necked	47
	<b>TVS - 7 NEW</b> Exotic Metals Variable Index Standard Length 7 Flute	49
	<b>TVM - 7 NEW</b> Exotic Metals Variable Index Medium Length 7 Flute	50
	<b>TVL - 7 NEW</b> Exotic Metals Variable Index Long Length 7 Flute	51
	<b>TVNS - 7 NEW</b> Exotic Metals Variable Index Standard Length 7 Flute Necked	52
	<b>TVNM - 7 NEW</b> Exotic Metals Variable Index Medium Length 7 Flute Necked	53
	<b>TVNL - 7 NEW</b> Exotic Metals Variable Index Long Length 7 Flute Necked	54
	<b>TFS</b> Exotic Metals Finishers Standard Length 6, 8, & 10 Flute	56
	<b>TFM</b> Exotic Metals Finishers Medium Length 6, 8, & 10 Flute	57
	<b>TFNS</b> Exotic Metals Finishers Standard Length 6, 8, & 10 Flute Necked	58
	<b>TFNM</b> Exotic Metals Finishers Medium Length 6, 8, & 10 Flute Necked	59
	<b>TFNL</b> Exotic Metals Finishers Long Length 6, 8, & 10 Flute Necked	60

## ROUTING TOOLS FOR SPECIAL APPLICATIONS

	<b>40-000</b> HSS 1 Flute Upcut Spiral	62
	<b>40-000</b> HSS 1 Flute Downcut Spiral	62
	<b>49-000</b> HSS 2 Flute Steel Downcut	62
	<b>62-600</b> SC 1 Flute "O" Flute Downcut Spiral	63
	<b>63-400</b> SC 1 Flute Upcut for Soft Aluminum	63
	<b>63-600</b> SC 1 Flute "O" Flute Upcut Spiral	64
	<b>63-900</b> SC 1 Flute "O" Flute Upcut Spiral	64



# AR & AF Series High Performance End Mills for Aluminum Applications

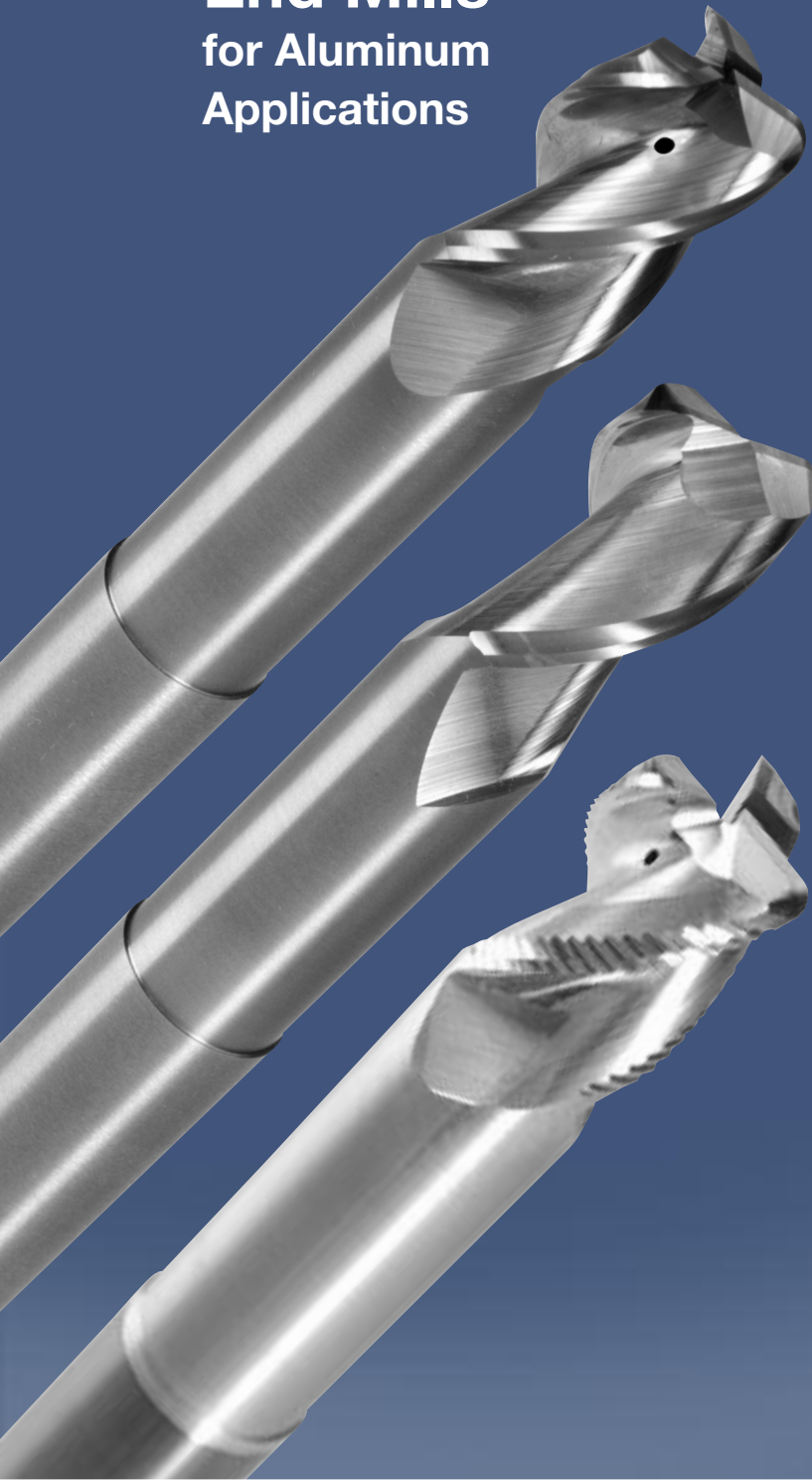

**Faster Machining** is what you get from LMT Onsrud's "AR" and "AF" performance line of End Mills for aluminum applications. The large "sweet spot" allows for chatter free machining at high RPM and heavy cuts. The resulting maximum metal removal rates mean maximum productivity in aluminum machining applications.

- 2 and 3 flute tools for both roughing and finishing applications
- 2 flute tools with open flute geometry optimized for slotting applications
- Polished flutes for better chip removal and low HP requirements
- 3 flute tools with large "sweet spot" for chatter free machining at high rpm and heavy cuts
- Efficient roughing metal removal rates up to 5 cubic inches per minute per HP
- Industry's largest selection of corner radii and neck and flute lengths in a standard program
- Available uncoated with high Polished Flutes & Specialty Coatings for Aluminum

If your machining center has **Coolant Through the Spindle** capabilities try the same 2 and 3 flute tools with Onsrud's unique coolant-through design that directs the coolant at the cutting edge. The coolant provides lubrication, dissipates heat and clears chips, which is especially important during deep cavity work, resulting in increased tool life and productivity levels.

Coolant at the cutting edge also contributes to superior finishes and prevents chips from adhering between the flutes. The unique design also maximizes the effect of "minimum quantity lubricant," or MQL, by ensuring that lubricant reaches the cutting edge of the tool.

**LMT ONSRUD**

# AF-2 & AF-3 SERIES TECHNICAL DATA FOR ALUMINUM



LMT Onsrud's aluminum tools are suitable for use in both low and high speed machining applications. Cutting recommendations listed below, either slotting or profiling, will assist in the reduction of chatter. Reduced chatter will increase tool life, produce a higher quality part, and optimize cutting efficiencies.

Optimized cutting combined with LMT Onsrud's consistent quality from tool to tool will result in the lowest cost per part possible.

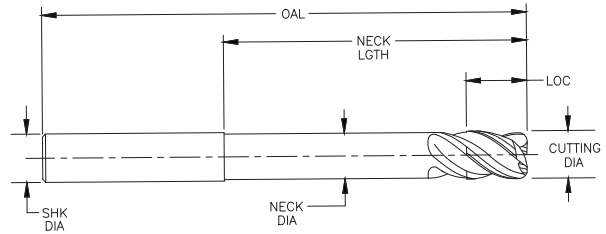

## CHIP LOAD PER TOOTH

		Aluminum									
Grade	Power Factor	SFM	1/8	3/16	1/4	5/16	3/8	1/2	5/8	3/4	1
<b>Aluminum 6061 / 7075</b>	4	500 / 1500									
Slotting			.0015	.0020	.0034	.0040	.0051	.0068	.0085	.0102	.0136
Profiling 33% RDoC			.0021	.0030	.0042	.0050	.0063	.0084	.0104	.0125	.0167
<b>Brass / Bronze</b>	8	500 / 900									
Slotting			.0010	.0020	.0028	.0030	.0042	.0057	.0071	.0086	.0115
Profiling 33% RDoC			.0020	.0030	.0034	.0045	.0052	.0070	.0087	.0105	.0141
<b>Copper Alloys</b>	2	700 / 1000									
Slotting			.0010	.0020	.0028	.0030	.0042	.0057	.0071	.0086	.0115
Profiling 33% RDoC			.0020	.0030	.0034	.0045	.0052	.0070	.0087	.0105	.0141
<b>Magnesium</b>	4	500 / 900									
Slotting			.0010	.0020	.0028	.0030	.0042	.0057	.0071	.0086	.0115
Profiling 33% RDoC			.0020	.0030	.0034	.0045	.0052	.0070	.0087	.0105	.0141

### Programming Tip:

Standard Length Tools Select SFM on High End of Recommendation  
 Medium Length Tools (2.5 X D) Reduce SFM by 25% from Top Speed  
 Long Length Tools (3 X D) Reduce SFM by 40-60% from Top Speed  
 Extra Long Tools (4 X D) Reduce SFM by 80-85% from Top Speed

### Necessary Formulas

- RPM = (3.82 x SFM)/tool dia.
- SFM = 3.14 x Diameter x RPM / 12
- Feed Rate (I.P.M) = F/T x # of Flutes x RPM
- Feed / Tooth = I.P.M / (RPM x # of Flutes)
- In<sup>3</sup> / Minute = I.P.M x ADoC x RDoC
- Horse Power Required = (In<sup>3</sup> / Min) / Power Factor
- Horse Power = 1.341 x kW

### Depths of Cut

- Profile Milling ADoC = 1 to 1.5 x Endmill Diameter  
RDoC = .2 to .5 x Endmill Diameter
- Slotting ADoC = .5 to 1 x Endmill Diameter

### Troubleshooting Cause & Effect

<b>Excessive Wear</b>	Increase Feed Rate
	Decrease RPM
	Increase DoC
<b>Chipping</b>	Increase RPM
	Decrease Feed Rate
	Increase DoC
<b>Build Up on Cutting Edge</b>	Double Check Speeds & Feeds
	Adjust RPM
	Increase Feed Rate
	Increase DoC
<b>Poor Finish / Chatter</b>	Reduce Gauge Length
	Ensure Rigidly of Tool Holder
	Check Tool Run Out
	Check for Tool Wear
<b>Tool Breakage @ Shank</b>	Decrease DoC
	Decrease Feed Rate
	Shorten Gauge Length



# AFS-2

## Standard Length 2 Flute

Aluminum 2 Flute

Description	Cutting DIA	SHK DIA	LOC	OAL	No of Flutes	Corner Radius	Uncoated EDP #	ZRN EDP #
AFS-20125	1/8	1/8	1/4	2	2	Square	• AMC400002	AMC400003
						0.010	AMC400004	AMC400005
						Ball	• AMC400006	AMC400007
AFS-20188	3/16	3/16	5/16	2	2	Square	• AMC400008	AMC400009
						0.010	AMC400010	AMC400011
						Ball	• AMC400012	AMC400013
AFS-20250	1/4	1/4	3/8	2	2	Square	• AMC700102	AMC700103
						0.015	• AMC700106	AMC700107
						0.030	• AMC700110	AMC700111
						0.060	AMC700114	AMC700115
						0.090	AMC700118	AMC700119
						Ball	• AMC700138	AMC700139
AFS-20313	5/16	5/16	9/16	2 1/2	2	Square	• AMC400014	AMC400015
						0.015	AMC400016	AMC400017
						Ball	• AMC400018	AMC400019
AFS-20375	3/8	3/8	1/2	2 1/2	2	Square	• AMC700202	AMC700203
						0.015	• AMC700206	AMC700207
						0.030	• AMC700210	AMC700211
						0.060	• AMC700214	AMC700215
						0.090	• AMC700218	AMC700219
						0.120	• AMC700222	AMC700223
						0.156	AMC700226	AMC700227
						Ball	• AMC700238	AMC700239
AFS-20500	1/2	1/2	5/8	3	2	Square	• AMC700302	AMC700303
						0.015	• AMC700306	AMC700307
						0.030	• AMC700310	AMC700311
						0.060	• AMC700314	AMC700315
						0.090	• AMC700318	AMC700319
						0.120	• AMC700322	AMC700323
						0.156	AMC700326	AMC700327
						Ball	• AMC700330	AMC700331
AFS-20625	5/8	5/8	3/4	3	2	Square	• AMC700402	AMC700403
						0.030	• AMC700410	AMC700411
						0.060	AMC700414	AMC700415
						0.090	AMC700418	AMC700419
						0.120	AMC700422	AMC700423
						0.156	AMC700426	AMC700427
						0.190	AMC700430	AMC700431
						0.250	AMC700434	AMC700435
						Ball	• AMC700438	AMC700439
						AFS-20750	3/4	3/4
0.030	• AMC700510	AMC700511						
0.060	• AMC700514	AMC700515						
0.090	• AMC700518	AMC700519						
0.120	• AMC700522	AMC700523						
0.156	AMC700526	AMC700527						
0.190	• AMC700530	AMC700531						
0.250	• AMC700534	AMC700535						
AFS-21000	1	1	1 1/4	4	2	Square	• AMC700602	AMC700603
						0.030	• AMC700610	AMC700611
						0.060	• AMC700614	AMC700615
						0.090	• AMC700618	AMC700619
						0.120	• AMC700622	AMC700623
						0.156	AMC700626	AMC700627
						0.190	• AMC700630	AMC700631
						0.250	• AMC700634	AMC700635
Ball	• AMC700638	AMC700639						

• = In-Stock

Lead Times for non-stock EDP Numbers are 6 working days for uncoated tools and 8 working days for coated tools.

# AFM-2

## Medium Length 2 Flute



Description	Cutting DIA	SHK DIA	LOC	OAL	No of Flutes	Corner Radius	Uncoated EDP #	ZRN EDP #
AFM-20125	1/8	1/8	1/2	2	2	Square	• AMC400020	AMC400021
						0.010	AMC400022	AMC400023
						Ball	• AMC400024	AMC400025
AFM-20188	3/16	3/16	9/16	2 1/2	2	Square	• AMC400026	AMC400027
						0.010	AMC400028	AMC400029
						Ball	• AMC400030	AMC400031
AFM-20250	1/4	1/4	3/4	2	2	Square	• AMC700752	AMC700753
						0.015	• AMC700756	AMC700757
						0.030	• AMC700760	AMC700761
						0.060	AMC700764	AMC700765
						0.090	AMC700768	AMC700769
						Ball	• AMC700788	AMC700789
AFM-20313	5/16	5/16	13/16	2 1/2	2	Square	• AMC400032	AMC400033
						0.015	AMC400034	AMC400035
						Ball	• AMC400036	AMC400037
AFM-20375	3/8	3/8	1	2 1/2	2	Square	• AMC700852	AMC700853
						0.015	• AMC700856	AMC700857
						0.030	• AMC700860	AMC700861
						0.060	• AMC700864	AMC700865
						0.090	• AMC700868	AMC700869
						0.120	• AMC700872	AMC700873
						0.156	AMC700876	AMC700877
Ball	• AMC700888	AMC700889						
AFM-20500	1/2	1/2	1 1/4	3	2	Square	• AMC700952	AMC700953
						0.015	• AMC700956	AMC700957
						0.030	• AMC700960	AMC700961
						0.060	• AMC700964	AMC700965
						0.090	• AMC700968	AMC700969
						0.120	• AMC700972	AMC700973
						0.156	AMC700976	AMC700977
AFM-20625	5/8	5/8	1 5/8	4	2	Square	• AMC701052	AMC701053
						0.030	• AMC701060	AMC701061
						0.060	AMC701064	AMC701065
						0.090	AMC701068	AMC701069
						0.120	AMC701072	AMC701073
						0.156	AMC701076	AMC701077
						0.190	AMC701080	AMC701081
AFM-20750	3/4	3/4	1 5/8	4	2	Square	• AMC701084	AMC701085
						0.250	AMC701088	AMC701089
						Ball	• AMC701088	AMC701089
						Square	• AMC701152	AMC701153
						0.030	• AMC701160	AMC701161
						0.060	• AMC701164	AMC701165
						0.090	• AMC701168	AMC701169
AFM-21000	1	1	2 1/2	5	2	Square	• AMC701172	AMC701173
						0.120	• AMC701176	AMC701177
						0.156	AMC701176	AMC701177
						0.190	• AMC701180	AMC701181
						0.250	• AMC701184	AMC701185
						Ball	• AMC701188	AMC701189
						Square	• AMC701252	AMC701253
AFM-21000	1	1	2 1/2	5	2	0.030	• AMC701260	AMC701261
						0.060	• AMC701264	AMC701265
						0.090	• AMC701268	AMC701269
						0.120	• AMC701272	AMC701273
						0.156	AMC701276	AMC701277
						0.190	• AMC701280	AMC701281
						0.250	• AMC701284	AMC701285
Ball	• AMC701288	AMC701289						

Aluminum 2 Flute





# AFL-2

## Long Length 2 Flute

Description	Cutting DIA	SHK DIA	LOC	OAL	No of Flutes	Corner Radius	Uncoated EDP #	ZRN EDP #	
AFL-20250	1/4	1/4	1 1/4	2 1/2	2	Square	• AMC701402	AMC701403	
							• AMC701406	AMC701407	
							0.030	AMC701410	AMC701411
							0.060	AMC701414	AMC701415
							0.090	AMC701418	AMC701419
							Ball	AMC701438	AMC701439
AFL-20375	3/8	3/8	1 1/2	4	2	Square	• AMC701502	AMC701503	
							• AMC701506	AMC701507	
							0.030	AMC701510	AMC701511
							0.060	AMC701514	AMC701515
							0.090	AMC701518	AMC701519
							0.120	AMC701522	AMC701523
AFL-20500	1/2	1/2	2	4	2	Square	• AMC701602	AMC701603	
							• AMC701606	AMC701607	
							0.030	AMC701610	AMC701611
							0.060	• AMC701614	AMC701615
							0.090	• AMC701618	AMC701619
							0.120	AMC701622	AMC701623
AFL-20625	5/8	5/8	2 1/4	5	2	Square	• AMC701702	AMC701703	
							• AMC701710	AMC701711	
							0.030	• AMC701714	AMC701715
							0.060	AMC701718	AMC701719
							0.090	AMC701722	AMC701723
							0.120	AMC701726	AMC701727
AFL-20750	3/4	3/4	2 1/2	5	2	Square	• AMC701802	AMC701803	
							• AMC701810	AMC701811	
							0.030	• AMC701814	AMC701815
							0.060	• AMC701818	AMC701819
							0.090	AMC701822	AMC701823
							0.120	AMC701826	AMC701827
AFL-21000	1	1	3 1/4	6	2	Square	• AMC701902	AMC701903	
							• AMC701910	AMC701911	
							0.030	• AMC701914	AMC701915
							0.060	• AMC701918	AMC701919
							0.090	AMC701922	AMC701923
							0.120	AMC701926	AMC701927
							• AMC701930	AMC701931	
							0.156	AMC701934	AMC701935
							0.190	AMC701938	AMC701939
							0.250		
							Ball		
							Ball		

• = In-Stock

Lead Times for non-stock EDP Numbers are 6 working days for uncoated tools and 8 working days for coated tools.

**AFX-2****Extra Long Length 2 Flute**

Description	Cutting DIA	SHK DIA	LOC	OAL	No of Flutes	Corner Radius	Uncoated EDP #	ZRN EDP #
AFX-20500	1/2	1/2	3 1/8	6	2	Square	AMC702252	AMC702253
						0.015	AMC702256	AMC702257
						0.030	AMC702260	AMC702261
						0.060	AMC702264	AMC702265
						0.090	AMC702268	AMC702269
						0.120	AMC702272	AMC702273
						0.156	AMC702276	AMC702277
						0.190	AMC702280	AMC702281
						Ball	AMC702288	AMC702289
						AFX-20625	5/8	5/8
0.030	AMC702360	AMC702361						
0.060	AMC702364	AMC702365						
0.090	AMC702368	AMC702369						
0.120	AMC702372	AMC702373						
0.156	AMC702376	AMC702377						
0.190	AMC702380	AMC702381						
0.250	AMC702384	AMC702385						
Ball	AMC702388	AMC702389						
AFX-20750	3/4	3/4	3 1/4	6	2			
						0.030	AMC702460	AMC702461
						0.060	AMC702464	AMC702465
						0.090	AMC702468	AMC702469
						0.120	AMC702472	AMC702473
						0.156	AMC702476	AMC702477
						0.190	AMC702480	AMC702481
						0.250	AMC702484	AMC702485
						Ball	AMC702488	AMC702489
						AFX-21000	1	1
0.030	AMC702560	AMC702561						
0.060	AMC702564	AMC702565						
0.090	AMC702568	AMC702569						
0.120	AMC702572	AMC702573						
0.156	AMC702576	AMC702577						
0.190	AMC702580	AMC702581						
0.250	AMC702584	AMC702585						
Ball	AMC702588	AMC702589						

• = In-Stock

Lead Times for non-stock EDP Numbers are 6 working days for uncoated tools and 8 working days for coated tools.



# AFNS-2

## Standard Length 2 Flute Necked

Aluminum 2 Flute Necked

Description	Cutting DIA	SHK DIA	LOC	OAL	No of Flutes	Neck LGTHS	Neck DIA	Corner Radius	Uncoated EDP #	ZRN EDP #
AFNS-20250	1/4	1/4	3/8	4	2	1 1/2	.236	Square	• AMC706102	AMC706103
								0.015	• AMC706106	AMC706107
								0.030	• AMC706110	AMC706111
								0.060	AMC706114	AMC706115
								0.090	AMC706118	AMC706119
								Ball	• AMC706138	AMC706139
AFNS-20375	3/8	3/8	1/2	4	2	1 3/4	.355	Square	• AMC706202	AMC706203
								0.015	• AMC706206	AMC706207
								0.030	• AMC706210	AMC706211
								0.060	• AMC706214	AMC706215
								0.090	• AMC706218	AMC706219
								0.120	• AMC706222	AMC706223
								0.156	AMC706226	AMC706227
								Ball	• AMC706238	AMC706239
AFNS-20500	1/2	1/2	5/8	4	2	2 1/8	.470	Square	• AMC706302	AMC706303
								0.015	• AMC706306	AMC706307
								0.030	• AMC706310	AMC706311
								0.060	• AMC706314	AMC706315
								0.090	• AMC706318	AMC706319
								0.120	• AMC706322	AMC706323
								0.156	AMC706326	AMC706327
								0.190	• AMC706330	AMC706331
Ball	• AMC706338	AMC706339								
AFNS-20625	5/8	5/8	3/4	4	2	2 1/8	.600	Square	• AMC706402	AMC706403
								0.030	• AMC706410	AMC706411
								0.060	• AMC706414	AMC706415
								0.090	• AMC706418	AMC706419
								0.120	AMC706422	AMC706423
								0.156	AMC706426	AMC706427
								0.190	AMC706430	AMC706431
								0.250	AMC706434	AMC706435
Ball	• AMC706438	AMC706439								
AFNS-20750	3/4	3/4	1	4	2	2 1/8	.715	Square	• AMC706502	AMC706503
								0.030	• AMC706510	AMC706511
								0.060	• AMC706514	AMC706515
								0.090	• AMC706518	AMC706519
								0.120	• AMC706522	AMC706523
								0.156	AMC706526	AMC706527
								0.190	• AMC706530	AMC706531
								0.250	• AMC706534	AMC706535
Ball	• AMC706538	AMC706539								
AFNS-21000	1	1	1 1/4	5	2	2 1/8	.955	Square	• AMC706602	AMC706603
								0.030	• AMC706610	AMC706611
								0.060	• AMC706614	AMC706615
								0.090	• AMC706618	AMC706619
								0.120	• AMC706622	AMC706623
								0.156	AMC706626	AMC706627
								0.190	• AMC706630	AMC706631
								0.250	• AMC706634	AMC706635
Ball	• AMC706638	AMC706639								

• = In-Stock

Lead Times for non-stock EDP Numbers are 6 working days for uncoated tools and 8 working days for coated tools.

# AFNM-2

## Medium Length 2 Flute Necked



Description	Cutting DIA	SHK DIA	LOC	OAL	No of Flutes	Neck LGTHS	Neck DIA	Corner Radius	Uncoated EDP #	ZRN EDP #
AFNM-20250	1/4	1/4	3/8	4	2	1 3/4	.236	Square	• AMC706752	AMC706753
								0.015	• AMC706756	AMC706757
								0.030	• AMC706760	AMC706761
								0.060	AMC706764	AMC706765
								0.090	AMC706768	AMC706769
								Ball	• AMC706788	AMC706789
AFNM-20375	3/8	3/8	1/2	4	2	2 1/4	.355	Square	• AMC706852	AMC706853
								0.015	• AMC706856	AMC706857
								0.030	• AMC706860	AMC706861
								0.060	• AMC706864	AMC706865
								0.090	• AMC706868	AMC706869
								0.120	• AMC706872	AMC706873
AFNM-20500	1/2	1/2	5/8	5	2	3 1/8	.470	Square	• AMC706952	AMC706953
								0.015	• AMC706956	AMC706957
								0.030	• AMC706960	AMC706961
								0.060	• AMC706964	AMC706965
								0.090	• AMC706968	AMC706969
								0.120	• AMC706972	AMC706973
AFNM-20625	5/8	5/8	3/4	5	2	3 1/8	.600	Square	• AMC707052	AMC707053
								0.030	• AMC707060	AMC707061
								0.060	• AMC707064	AMC707065
								0.090	• AMC707068	AMC707069
								0.120	• AMC707072	AMC707073
								0.156	AMC707076	AMC707077
AFNM-20750	3/4	3/4	1	5	2	3 1/8	.715	Square	• AMC707152	AMC707153
								0.030	• AMC707160	AMC707161
								0.060	• AMC707164	AMC707165
								0.090	• AMC707168	AMC707169
								0.120	• AMC707172	AMC707173
								0.156	AMC707176	AMC707177
AFNM-21000	1	1	1 1/4	6	2	3 1/8	.955	Square	• AMC707252	AMC707253
								0.030	• AMC707260	AMC707261
								0.060	• AMC707264	AMC707265
								0.090	• AMC707268	AMC707269
								0.120	• AMC707272	AMC707273
								0.156	AMC707276	AMC707277
								0.190	• AMC707280	AMC707281
								0.250	• AMC707284	AMC707285
								Ball	• AMC707288	AMC707289

• = In-Stock

Lead Times for non-stock EDP Numbers are 6 working days for uncoated tools and 8 working days for coated tools.



# AFNL-2

## Long Length 2 Flute Necked

Aluminum 2 Flute Necked

Description	Cutting DIA	SHK DIA	LOC	OAL	No of Flutes	Neck LGTHS	Neck DIA	Corner Radius	Uncoated EDP #	ZRN EDP #
AFNL-20250	1/4	1/4	3/8	4	2	2 1/8	.236	Square	• AMC707402	AMC707403
								0.015	• AMC707406	AMC707407
								0.030	• AMC707410	AMC707411
								0.060	AMC707414	AMC707415
								0.090	AMC707418	AMC707419
								Ball	• AMC707438	AMC707439
AFNL-20375	3/8	3/8	1/2	5	2	2 3/4	.355	Square	• AMC707502	AMC707503
								0.015	• AMC707506	AMC707507
								0.030	• AMC707510	AMC707511
								0.060	• AMC707514	AMC707515
								0.090	• AMC707518	AMC707519
								0.120	• AMC707522	AMC707523
AFNL-20500	1/2	1/2	5/8	6	2	4 1/8	.470	Square	• AMC707602	AMC707603
								0.015	• AMC707606	AMC707607
								0.030	• AMC707610	AMC707611
								0.060	• AMC707614	AMC707615
								0.090	• AMC707618	AMC707619
								0.120	• AMC707622	AMC707623
AFNL-20625	5/8	5/8	3/4	6	2	4 1/8	.600	Square	• AMC707702	AMC707703
								0.030	• AMC707710	AMC707711
								0.060	• AMC707714	AMC707715
								0.090	• AMC707718	AMC707719
								0.120	• AMC707722	AMC707723
								0.156	AMC707726	AMC707727
AFNL-20750	3/4	3/4	1	6	2	4 1/8	.715	Square	• AMC707802	AMC707803
								0.030	• AMC707810	AMC707811
								0.060	• AMC707814	AMC707815
								0.090	• AMC707818	AMC707819
								0.120	• AMC707822	AMC707823
								0.156	AMC707826	AMC707827
AFNL-21000	1	1	1 1/4	7	2	4 1/8	.955	Square	• AMC707902	AMC707903
								0.030	• AMC707910	AMC707911
								0.060	• AMC707914	AMC707915
								0.090	• AMC707918	AMC707919
								0.120	• AMC707922	AMC707923
								0.156	AMC707926	AMC707927
								0.190	• AMC707930	AMC707931
								0.250	• AMC707934	AMC707935
								Ball	• AMC707938	AMC707939

• = In-Stock

Lead Times for non-stock EDP Numbers are 6 working days for uncoated tools and 8 working days for coated tools.



# AFNX-2

## Extra Long Length 2 Flute Necked



Description	Cutting DIA	SHK DIA	LOC	OAL	No of Flutes	Neck LGTHS	Neck DIA	Corner Radius	Uncoated EDP #	ZRN EDP #
AFNX-21000	1	1	1 1/4	7	2	4 5/8	.955	Square	AMC707952	AMC707953
								0.030	AMC707960	AMC707961
								0.060	AMC707964	AMC707965
								0.090	AMC707968	AMC707969
								0.120	AMC707972	AMC707973
								0.156	AMC707976	AMC707977
								0.190	AMC707980	AMC707981
								0.250	AMC707984	AMC707985
								Ball	AMC707988	AMC707989

• = In-Stock

Lead Times for non-stock EDP Numbers are 6 working days for uncoated tools and 8 working days for coated tools.



# AFS-3

## Standard Length 3 Flute

Aluminum 3 Flute

Description	Cutting DIA	SHK DIA	LOC	OAL	No of Flutes	Corner Radius	Uncoated EDP #	ZRN EDP #
AFS-30125	1/8	1/8	1/4	2	3	Square	• AMC400038	AMC400039
						0.010	AMC400040	AMC400041
						Ball	• AMC400042	AMC400043
AFS-30188	3/16	3/16	5/16	2	3	Square	• AMC400044	AMC400045
						0.010	AMC400046	AMC400047
						Ball	• AMC400048	AMC400049
AFS-30250	1/4	1/4	3/8	2	3	Square	• AMC703102	AMC703103
						0.015	• AMC703106	AMC703107
						0.030	• AMC703110	AMC703111
						0.060	AMC703114	AMC703115
						0.090	AMC703118	AMC703119
						Ball	• AMC703138	AMC703139
AFS-30313	5/16	5/16	9/16	2 1/2	3	Square	• AMC400050	AMC400051
						0.015	AMC400052	AMC400053
						Ball	• AMC400054	AMC400055
AFS-30375	3/8	3/8	1/2	2 1/2	3	Square	• AMC703202	AMC703203
						0.015	• AMC703206	AMC703207
						0.030	• AMC703210	AMC703211
						0.060	• AMC703214	AMC703215
						0.090	• AMC703218	AMC703219
						0.120	• AMC703222	AMC703223
						0.156	AMC703226	AMC703227
						Ball	• AMC703238	AMC703239
AFS-30500	1/2	1/2	5/8	3	3	Square	• AMC703302	AMC703303
						0.015	• AMC703306	AMC703307
						0.030	• AMC703310	AMC703311
						0.060	• AMC703314	AMC703315
						0.090	• AMC703318	AMC703319
						0.120	• AMC703322	AMC703323
						0.156	AMC703326	AMC703327
						Ball	• AMC703330	AMC703331
AFS-30625	5/8	5/8	3/4	3	3	Square	• AMC703402	AMC703403
						0.030	• AMC703410	AMC703411
						0.060	AMC703414	AMC703415
						0.090	AMC703418	AMC703419
						0.120	AMC703422	AMC703423
						0.156	AMC703426	AMC703427
						0.190	AMC703430	AMC703431
						0.250	AMC703434	AMC703435
						Ball	• AMC703438	AMC703439
						AFS-30750	3/4	3/4
0.030	• AMC703510	AMC703511						
0.060	• AMC703514	AMC703515						
0.090	• AMC703518	AMC703519						
0.120	• AMC703522	AMC703523						
0.156	AMC703526	AMC703527						
0.190	• AMC703530	AMC703531						
0.250	• AMC703534	AMC703535						
AFS-31000	1	1	1 1/4	4	3	Square	• AMC703602	AMC703603
						0.030	• AMC703610	AMC703611
						0.060	• AMC703614	AMC703615
						0.090	• AMC703618	AMC703619
						0.120	• AMC703622	AMC703623
						0.156	AMC703626	AMC703627
						0.190	• AMC703630	AMC703631
						0.250	• AMC703634	AMC703635
Ball	• AMC703638	AMC703639						

• = In-Stock

Lead Times for non-stock EDP Numbers are 6 working days for uncoated tools and 8 working days for coated tools.

# AFM-3

## Medium Length 3 Flute



Description	Cutting DIA	SHK DIA	LOC	OAL	No of Flutes	Corner Radius	Uncoated EDP #	ZRN EDP #
AFM-30125	1/8	1/8	1/2	2	3	Square	• AMC400056	AMC400057
						0.010	AMC400058	AMC400059
						Ball	• AMC400060	AMC400061
AFM-30188	3/16	3/16	9/16	2 1/2	3	Square	• AMC400062	AMC400063
						0.010	AMC400064	AMC400065
						Ball	• AMC400066	AMC400067
AFM-30250	1/4	1/4	3/4	2	3	Square	• AMC703752	AMC703753
						0.015	• AMC703756	AMC703757
						0.030	• AMC703760	AMC703761
						0.060	AMC703764	AMC703765
						0.090	AMC703768	AMC703769
						Ball	• AMC703788	AMC703789
AFM-30313	5/16	5/16	13/16	2 1/2	3	Square	• AMC400068	AMC400069
						0.015	AMC400070	AMC400071
						Ball	• AMC400074	AMC400075
AFM-30375	3/8	3/8	1	2 1/2	3	Square	• AMC703852	AMC703853
						0.015	• AMC703856	AMC703857
						0.030	• AMC703860	AMC703861
						0.060	• AMC703864	AMC703865
						0.090	• AMC703868	AMC703869
						0.120	• AMC703872	AMC703873
						0.156	AMC703876	AMC703877
Ball	• AMC703888	AMC703889						
AFM-30500	1/2	1/2	1 1/4	3	3	Square	• AMC703952	AMC703953
						0.015	• AMC703956	AMC703957
						0.030	• AMC703960	AMC703961
						0.060	• AMC703964	AMC703965
						0.090	• AMC703968	AMC703969
						0.120	• AMC703972	AMC703973
						0.156	AMC703976	AMC703977
AFM-30625	5/8	5/8	1 5/8	4	3	Square	• AMC704052	AMC704053
						0.030	• AMC704060	AMC704061
						0.060	AMC704064	AMC704065
						0.090	AMC704068	AMC704069
						0.120	AMC704072	AMC704073
						0.156	AMC704076	AMC704077
						0.190	AMC704080	AMC704081
AFM-30750	3/4	3/4	1 5/8	4	3	Square	• AMC704084	AMC704085
						0.250	AMC704088	AMC704089
						Ball	• AMC704088	AMC704089
						Square	• AMC704152	AMC704153
						0.030	• AMC704160	AMC704161
						0.060	• AMC704164	AMC704165
						0.090	• AMC704168	AMC704169
AFM-31000	1	1	2 1/2	5	3	Square	• AMC704172	AMC704173
						0.120	• AMC704176	AMC704177
						0.156	AMC704180	AMC704181
						0.190	• AMC704184	AMC704185
						0.250	• AMC704188	AMC704189
						Ball	• AMC704188	AMC704189
						Square	• AMC704252	AMC704253
AFM-31000	1	1	2 1/2	5	3	0.030	• AMC704260	AMC704261
						0.060	• AMC704264	AMC704265
						0.090	• AMC704268	AMC704269
						0.120	• AMC704272	AMC704273
						0.156	AMC704276	AMC704277
						0.190	• AMC704280	AMC704281
						0.250	• AMC704284	AMC704285
Ball	• AMC704288	AMC704289						



# AFL-3

## Long Length 3 Flute

Aluminum 3 Flute

Description	Cutting DIA	SHK DIA	LOC	OAL	No of Flutes	Corner Radius	Uncoated EDP #	ZRN EDP #	
AFL-30250	1/4	1/4	1 1/4	2 1/2	3	Square	• AMC704402	AMC704403	
							• AMC704406	AMC704407	
							0.030	AMC704410	AMC704411
							0.060	AMC704414	AMC704415
							0.090	AMC704418	AMC704419
							Ball	AMC704438	AMC704439
AFL-30375	3/8	3/8	1 1/2	4	3	Square	• AMC704502	AMC704503	
							• AMC704506	AMC704507	
							0.030	AMC704510	AMC704511
							0.060	AMC704514	AMC704515
							0.090	AMC704518	AMC704519
							0.120	AMC704522	AMC704523
AFL-30500	1/2	1/2	2	4	3	Square	• AMC704602	AMC704603	
							• AMC704606	AMC704607	
							0.030	• AMC704610	AMC704611
							0.060	• AMC704614	AMC704615
							0.090	AMC704618	AMC704619
							0.120	AMC704622	AMC704623
AFL-30625	5/8	5/8	2 1/4	5	3	Square	• AMC704702	AMC704703	
							• AMC704710	AMC704711	
							0.030	AMC704714	AMC704715
							0.060	AMC704718	AMC704719
							0.090	AMC704722	AMC704723
							0.120	AMC704726	AMC704727
AFL-30750	3/4	3/4	2 1/2	5	3	Square	• AMC704802	AMC704803	
							• AMC704810	AMC704811	
							0.030	• AMC704814	AMC704815
							0.060	• AMC704818	AMC704819
							0.090	AMC704822	AMC704823
							0.120	AMC704826	AMC704827
AFL-31000	1	1	3 1/4	6	3	Square	• AMC704902	AMC704903	
							• AMC704910	AMC704911	
							0.030	• AMC704914	AMC704915
							0.060	• AMC704918	AMC704919
							0.090	AMC704922	AMC704923
							0.120	AMC704926	AMC704927
							• AMC704930	AMC704931	
							• AMC704934	AMC704935	
							0.156	AMC704938	AMC704939
							0.190	AMC704938	AMC704939
							0.250	AMC704938	AMC704939
							Ball	AMC704938	AMC704939

• = In-Stock

Lead Times for non-stock EDP Numbers are 6 working days for uncoated tools and 8 working days for coated tools.

# AFX-3

## Extra Long Length 3 Flute



Description	Cutting DIA	SHK DIA	LOC	OAL	No of Flutes	Corner Radius	Uncoated EDP #	ZRN EDP #
AFX-30500	1/2	1/2	3 1/8	6	3	Square	AMC705252	AMC705253
						0.015	AMC705256	AMC705257
						0.030	AMC705260	AMC705261
						0.060	AMC705264	AMC705265
						0.090	AMC705268	AMC705269
						0.120	AMC705272	AMC705273
						0.156	AMC705276	AMC705277
						0.190	AMC705280	AMC705281
						Ball	AMC705288	AMC705289
						AFX-30625	5/8	5/8
0.030	AMC705360	AMC705361						
0.060	AMC705364	AMC705365						
0.090	AMC705368	AMC705369						
0.120	AMC705372	AMC705373						
0.156	AMC705376	AMC705377						
0.190	AMC705380	AMC705381						
0.250	AMC705384	AMC705385						
Ball	AMC705388	AMC705389						
AFX-30750	3/4	3/4	3 1/4	6	3			
						0.030	AMC705460	AMC705461
						0.060	AMC705464	AMC705465
						0.090	AMC705468	AMC705469
						0.120	AMC705472	AMC705473
						0.156	AMC705476	AMC705477
						0.190	AMC705480	AMC705481
						0.250	AMC705484	AMC705485
						Ball	AMC705488	AMC705489
						AFX-31000	1	1
0.030	AMC705560	AMC705561						
0.060	AMC705564	AMC705565						
0.090	AMC705568	AMC705569						
0.120	AMC705572	AMC705573						
0.156	AMC705576	AMC705577						
0.190	AMC705580	AMC705581						
0.250	AMC705584	AMC705585						
Ball	AMC705588	AMC705589						

• = In-Stock

Lead Times for non-stock EDP Numbers are 6 working days for uncoated tools and 8 working days for coated tools.





# AFNS-3

## Standard Length 3 Flute Necked

Aluminum 3 Flute Necked

Description	Cutting DIA	SHK DIA	LOC	OAL	No of Flutes	Neck LGTHS	Neck DIA	Corner Radius	Uncoated EDP #	ZRN EDP #
AFNS-30250	1/4	1/4	3/8	4	3	1 1/2	.236	Square	• AMC709102	AMC709103
								0.015	• AMC709106	AMC709107
								0.030	• AMC709110	AMC709111
								0.060	AMC709114	AMC709115
								0.090	AMC709118	AMC709119
								Ball	• AMC709138	AMC709139
AFNS-30375	3/8	3/8	1/2	4	3	1 3/4	.355	Square	• AMC709202	AMC709203
								0.015	• AMC709206	AMC709207
								0.030	• AMC709210	AMC709211
								0.060	• AMC709214	AMC709215
								0.090	• AMC709218	AMC709219
								0.120	• AMC709222	AMC709223
								0.156	AMC709226	AMC709227
Ball	• AMC709238	AMC709239								
AFNS-30500	1/2	1/2	5/8	4	3	2 1/8	.470	Square	• AMC709302	AMC709303
								0.015	• AMC709306	AMC709307
								0.030	• AMC709310	AMC709311
								0.060	• AMC709314	AMC709315
								0.090	• AMC709318	AMC709319
								0.120	• AMC709322	AMC709323
								0.156	AMC709326	AMC709327
								0.190	• AMC709330	AMC709331
Ball	• AMC709338	AMC709339								
AFNS-30625	5/8	5/8	3/4	4	3	2 1/8	.600	Square	• AMC709402	AMC709403
								0.030	• AMC709410	AMC709411
								0.060	• AMC709414	AMC709415
								0.090	• AMC709418	AMC709419
								0.120	• AMC709422	AMC709423
								0.156	AMC709426	AMC709427
								0.190	AMC709430	AMC709431
								0.250	AMC709434	AMC709435
Ball	• AMC709438	AMC709439								
AFNS-30750	3/4	3/4	1	4	3	2 1/8	.715	Square	• AMC709502	AMC709503
								0.030	• AMC709510	AMC709511
								0.060	• AMC709514	AMC709515
								0.090	• AMC709518	AMC709519
								0.120	• AMC709522	AMC709523
								0.156	AMC709526	AMC709527
								0.190	• AMC709530	AMC709531
								0.250	• AMC709534	AMC709535
Ball	• AMC709538	AMC709539								
AFNS-31000	1	1	1 1/4	5	3	2 1/8	.955	Square	• AMC709602	AMC709603
								0.030	• AMC709610	AMC709611
								0.060	• AMC709614	AMC709615
								0.090	• AMC709618	AMC709619
								0.120	• AMC709622	AMC709623
								0.156	AMC709626	AMC709627
								0.190	• AMC709630	AMC709631
								0.250	• AMC709634	AMC709635
Ball	• AMC709638	AMC709639								

• = In-Stock

Lead Times for non-stock EDP Numbers are 6 working days for uncoated tools and 8 working days for coated tools.

# AFNM-3

## Medium Length 3 Flute Necked



Description	Cutting DIA	SHK DIA	LOC	OAL	No of Flutes	Neck LGTHS	Neck DIA	Corner Radius	Uncoated EDP #	ZRN EDP #
AFNM-30250	1/4	1/4	3/8	4	3	1 3/4	.236	Square	• AMC709752	AMC709753
								0.015	• AMC709756	AMC709757
								0.030	• AMC709760	AMC709761
								0.060	AMC709764	AMC709765
								0.090	AMC709768	AMC709769
								Ball	• AMC709788	AMC709789
AFNM-30375	3/8	3/8	1/2	4	3	2 1/4	.355	Square	• AMC709852	AMC709853
								0.015	• AMC709856	AMC709857
								0.030	• AMC709860	AMC709861
								0.060	• AMC709864	AMC709865
								0.090	• AMC709868	AMC709869
								0.120	• AMC709872	AMC709873
AFNM-30500	1/2	1/2	5/8	5	3	3 1/8	.470	Square	• AMC709952	AMC709953
								0.015	• AMC709956	AMC709957
								0.030	• AMC709960	AMC709961
								0.060	• AMC709964	AMC709965
								0.090	• AMC709968	AMC709969
								0.120	• AMC709972	AMC709973
AFNM-30625	5/8	5/8	3/4	5	3	3 1/8	.600	Square	• AMC710052	AMC710053
								0.030	• AMC710060	AMC710061
								0.060	• AMC710064	AMC710065
								0.090	• AMC710068	AMC710069
								0.120	• AMC710072	AMC710073
								0.156	AMC710076	AMC710077
AFNM-30750	3/4	3/4	1	5	3	3 1/8	.715	Square	• AMC710152	AMC710153
								0.030	• AMC710160	AMC710161
								0.060	• AMC710164	AMC710165
								0.090	• AMC710168	AMC710169
								0.120	• AMC710172	AMC710173
								0.156	AMC710176	AMC710177
AFNM-31000	1	1	1 1/4	6	3	3 1/8	.955	Square	• AMC710252	AMC710253
								0.030	• AMC710260	AMC710261
								0.060	• AMC710264	AMC710265
								0.090	• AMC710268	AMC710269
								0.120	• AMC710272	AMC710273
								0.156	AMC710276	AMC710277
								0.190	• AMC710280	AMC710281
								0.250	• AMC710284	AMC710285
								Ball	• AMC710288	AMC710289

• = In-Stock

Lead Times for non-stock EDP Numbers are 6 working days for uncoated tools and 8 working days for coated tools.



# AFNL-3

## Long Length 3 Flute Necked

Aluminum 3 Flute Necked

Description	Cutting DIA	SHK DIA	LOC	OAL	No of Flutes	Neck LGTHS	Neck DIA	Corner Radius	Uncoated EDP #	ZRN EDP #
AFNL-30250	1/4	1/4	3/8	4	3	2 1/8	.236	Square	• AMC710402	AMC710403
								0.015	• AMC710406	AMC710407
								0.030	• AMC710410	AMC710411
								0.060	AMC710414	AMC710415
								0.090	AMC710418	AMC710419
								Ball	• AMC710438	AMC710439
AFNL-30375	3/8	3/8	1/2	5	3	2 3/4	.355	Square	• AMC710502	AMC710503
								0.015	• AMC710506	AMC710507
								0.030	• AMC710510	AMC710511
								0.060	• AMC710514	AMC710515
								0.090	• AMC710518	AMC710519
								0.120	• AMC710522	AMC710523
AFNL-30500	1/2	1/2	5/8	6	3	4 1/8	.470	Square	• AMC710602	AMC710603
								0.015	• AMC710606	AMC710607
								0.030	• AMC710610	AMC710611
								0.060	• AMC710614	AMC710615
								0.090	• AMC710618	AMC710619
								0.120	• AMC710622	AMC710623
AFNL-30625	5/8	5/8	3/4	6	3	4 1/8	.600	Square	• AMC710702	AMC710703
								0.030	• AMC710710	AMC710711
								0.060	• AMC710714	AMC710715
								0.090	• AMC710718	AMC710719
								0.120	• AMC710722	AMC710723
								0.156	AMC710726	AMC710727
AFNL-30750	3/4	3/4	1	6	3	4 1/8	.715	Square	• AMC710802	AMC710803
								0.030	• AMC710810	AMC710811
								0.060	• AMC710814	AMC710815
								0.090	• AMC710818	AMC710819
								0.120	• AMC710822	AMC710823
								0.156	AMC710826	AMC710827
AFNL-31000	1	1	1 1/4	7	3	4 1/8	.955	Square	• AMC710902	AMC710903
								0.030	• AMC710910	AMC710911
								0.060	• AMC710914	AMC710915
								0.090	• AMC710918	AMC710919
								0.120	• AMC710922	AMC710923
								0.156	AMC710926	AMC710927
								0.190	• AMC710930	AMC710931
								0.250	• AMC710934	AMC710935
								Ball	• AMC710938	AMC710939

• = In-Stock

Lead Times for non-stock EDP Numbers are 6 working days for uncoated tools and 8 working days for coated tools.

# AFNX-3

## Extra Long Length 3 Flute Necked



Description	Cutting DIA	SHK DIA	LOC	OAL	No of Flutes	Neck LGTHS	Neck DIA	Corner Radius	Uncoated EDP #	ZRN EDP #
AFNX-31000	1	1	1 1/4	7	3	4 5/8	.955	Square	AMC710952	AMC710953
								0.030	AMC710960	AMC710961
								0.060	AMC710964	AMC710965
								0.090	AMC710968	AMC710969
								0.120	AMC710972	AMC710973
								0.156	AMC710976	AMC710977
								0.190	AMC710980	AMC710981
								0.250	AMC710984	AMC710985
								Ball	AMC710988	AMC710989

• = In-Stock

Lead Times for non-stock EDP Numbers are 6 working days for uncoated tools and 8 working days for coated tools.

# AFC-2 & AFC-3 SERIES TECHNICAL DATA FOR ALUMINUM COOLANT THROUGH END MILLS

Slot over 15% Faster with  
with Onsrud's 2 & 3 Flute  
High-Performance  
Coolant Through End Mills

LMT Onsrud's standard radial coolant hole design directs coolant at the cutting edge which provides lubrication, heat dissipation and chip evacuation. These benefits all improve performance in low and high speed machining.

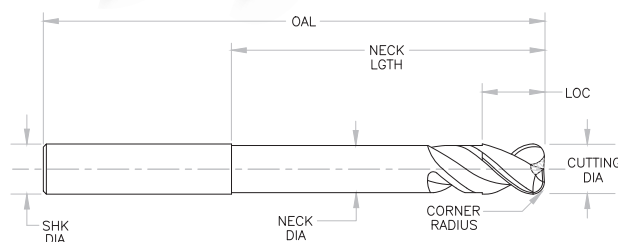

## CHIP LOAD PER TOOTH

Grade	Power Factor	Aluminum Coolant Through						
		SFM	1/4	3/8	1/2	5/8	3/4	1
<b>Aluminum 6061/7075</b>	4	500/1500						
Slotting			.0041	.0061	.0081	.0101	.0121	.0162
Profiling 33% RDoC			.0049	.0073	.0097	.0120	.0144	.0193
<b>Brass/Bronze</b>	8	500/900						
Slotting			.0034	.0051	.0068	.0085	.0102	.0136
Profiling 33% RDoC			.0040	.0061	.0081	.0101	.0121	.0162
<b>Copper Alloys</b>	2	700/1000						
Slotting			.0034	.0051	.0068	.0085	.0102	.0136
Profiling 33% RDoC			.0040	.0061	.0081	.0101	.0121	.0162
<b>Magnesium</b>	4	500/900						
Slotting			.0034	.0051	.0068	.0085	.0102	.0136
Profiling 33% RDoC			.0040	.0061	.0081	.0101	.0121	.0162



# AFCNS-2

## Standard Length 2 Flute Necked



Description	Cutting DIA	SHK DIA	LOC	OAL	No of Flutes	Neck LGTHS	Neck DIA	Corner Radius	Uncoated EDP #	ZRN EDP #
AFCNS-20250	1/4	1/4	3/8	4	2	1 1/2	.236	Square	• AMC712102	AMC712103
								0.015	• AMC712106	AMC712107
								0.030	AMC712110	AMC712111
								0.060	AMC712114	AMC712115
								0.090	AMC712118	AMC712119
								Ball	• AMC712138	AMC712139
AFCNS-20375	3/8	3/8	1/2	4	2	1 3/4	.355	Square	• AMC712202	AMC712203
								0.015	• AMC712206	AMC712207
								0.030	AMC712210	AMC712211
								0.060	AMC712214	AMC712215
								0.090	AMC712218	AMC712219
								0.120	AMC712222	AMC712223
AFCNS-20500	1/2	1/2	5/8	4	2	2 1/8	.470	Square	• AMC712302	AMC712303
								0.015	• AMC712306	AMC712307
								0.030	AMC712310	AMC712311
								0.060	• AMC712314	AMC712315
								0.090	• AMC712318	AMC712319
								0.120	• AMC712322	AMC712323
AFCNS-20625	5/8	5/8	3/4	4	2	2 1/8	.600	Square	• AMC712402	AMC712403
								0.030	• AMC712410	AMC712411
								0.060	• AMC712414	AMC712415
								0.090	• AMC712418	AMC712419
								0.120	• AMC712422	AMC712423
								0.156	AMC712426	AMC712427
AFCNS-20750	3/4	3/4	1	4	2	2 1/8	.715	Square	• AMC712502	AMC712503
								0.030	• AMC712510	AMC712511
								0.060	• AMC712514	AMC712515
								0.090	• AMC712518	AMC712519
								0.120	• AMC712522	AMC712523
								0.156	AMC712526	AMC712527
AFCNS-21000	1	1	1 1/4	5	2	2 1/8	.955	Square	• AMC712602	AMC712603
								0.030	• AMC712610	AMC712611
								0.060	• AMC712614	AMC712615
								0.090	• AMC712618	AMC712619
								0.120	• AMC712622	AMC712623
								0.156	AMC712626	AMC712627
								0.190	AMC712630	AMC712631
								0.250	AMC712634	AMC712635
								Ball	• AMC712638	AMC712639

• = In-Stock

Lead Times for non-stock EDP Numbers are 6 working days for uncoated tools and 8 working days for coated tools.



## AFCNM-2 Medium Length 2 Flute Necked

Description	Cutting DIA	SHK DIA	LOC	OAL	No of Flutes	Neck LGTHS	Neck DIA	Corner Radius	Uncoated EDP #	ZRN EDP #
AFCNM-20250	1/4	1/4	3/8	4	2	1 3/4	.236	Square	• AMC712752	AMC712753
								0.015	• AMC712756	AMC712757
								0.030	AMC712760	AMC712761
								0.060	AMC712764	AMC712765
								0.090	AMC712768	AMC712769
								Ball	• AMC712788	AMC712789
AFCNM-20375	3/8	3/8	1/2	4	2	2 1/4	.355	Square	• AMC712852	AMC712853
								0.015	• AMC712856	AMC712857
								0.030	AMC712860	AMC712861
								0.060	AMC712864	AMC712865
								0.090	AMC712868	AMC712869
								0.120	AMC712872	AMC712873
AFCNM-20500	1/2	1/2	5/8	5	2	3 1/8	.470	Square	• AMC712952	AMC712953
								0.015	• AMC712956	AMC712957
								0.030	AMC712960	AMC712961
								0.060	• AMC712964	AMC712965
								0.090	• AMC712968	AMC712969
								0.120	AMC712972	AMC712973
AFCNM-20625	5/8	5/8	3/4	6	2	3 1/8	.600	Square	• AMC713052	AMC713053
								0.030	• AMC713060	AMC713061
								0.060	• AMC713064	AMC713065
								0.090	• AMC713068	AMC713069
								0.120	• AMC713072	AMC713073
								0.156	AMC713076	AMC713077
AFCNM-20750	3/4	3/4	1	6	2	3 1/8	.715	Square	• AMC713152	AMC713153
								0.030	• AMC713160	AMC713161
								0.060	• AMC713164	AMC713165
								0.090	• AMC713168	AMC713169
								0.120	• AMC713172	AMC713173
								0.156	AMC713176	AMC713177
AFCNM-21000	1	1	1 1/4	6	2	3 1/8	.955	Square	• AMC713252	AMC713253
								0.030	• AMC713260	AMC713261
								0.060	• AMC713264	AMC713265
								0.090	• AMC713268	AMC713269
								0.120	• AMC713272	AMC713273
								0.156	AMC713276	AMC713277
								0.190	AMC713280	AMC713281
								0.250	AMC713284	AMC713285
								Ball	• AMC713288	AMC713289

• = In-Stock

Lead Times for non-stock EDP Numbers are 6 working days for uncoated tools and 8 working days for coated tools.

# AFCNL-2

## Long Length 2 Flute Necked



Description	Cutting DIA	SHK DIA	LOC	OAL	No of Flutes	Neck LGTHS	Neck DIA	Corner Radius	Uncoated EDP #	ZRN EDP #
AFCNL-20250	1/4	1/4	3/8	4	2	2 1/8	.236	Square	• AMC713402	AMC713403
								0.015	• AMC713406	AMC713407
								0.030	AMC713410	AMC713411
								0.060	AMC713414	AMC713415
								0.090	AMC713418	AMC713419
								Ball	• AMC713438	AMC713439
AFCNL-20375	3/8	3/8	1/2	5	2	2 3/4	.355	Square	• AMC713502	AMC713503
								0.015	• AMC713506	AMC713507
								0.030	AMC713510	AMC713511
								0.060	AMC713514	AMC713515
								0.090	AMC713518	AMC713519
								0.120	AMC713522	AMC713523
								0.156	AMC713526	AMC713527
								Ball	• AMC713538	AMC713539
AFCNL-20500	1/2	1/2	5/8	6	2	4 1/8	.470	Square	• AMC713602	AMC713603
								0.015	• AMC713606	AMC713607
								0.030	AMC713610	AMC713611
								0.060	AMC713614	AMC713615
								0.090	AMC713618	AMC713619
								0.120	AMC713622	AMC713623
								0.156	AMC713626	AMC713627
								0.190	AMC713630	AMC713631
Ball	• AMC713638	AMC713639								
AFCNL-20625	5/8	5/8	3/4	6	2	4 1/8	.600	Square	• AMC713702	AMC713703
								0.030	• AMC713710	AMC713711
								0.060	AMC713714	AMC713715
								0.090	AMC713718	AMC713719
								0.120	• AMC713722	AMC713723
								0.156	AMC713726	AMC713727
								0.190	AMC713730	AMC713731
								0.250	AMC713734	AMC713735
Ball	• AMC713738	AMC713739								
AFCNL-20750	3/4	3/4	1	6	2	4 1/8	.715	Square	• AMC713802	AMC713803
								0.030	• AMC713810	AMC713811
								0.060	AMC713814	AMC713815
								0.090	AMC713818	AMC713819
								0.120	• AMC713822	AMC713823
								0.156	AMC713826	AMC713827
								0.190	AMC713830	AMC713831
								0.250	AMC713834	AMC713835
Ball	• AMC713838	AMC713839								
AFCNL-21000	1	1	1 1/4	7	2	4 1/8	.955	Square	• AMC713902	AMC713903
								0.030	• AMC713910	AMC713911
								0.060	AMC713914	AMC713915
								0.090	AMC713918	AMC713919
								0.120	• AMC713922	AMC713923
								0.156	AMC713926	AMC713927
								0.190	AMC713930	AMC713931
								0.250	AMC713934	AMC713935
Ball	• AMC713938	AMC713939								

• = In-Stock

Lead Times for non-stock EDP Numbers are 6 working days for uncoated tools and 8 working days for coated tools.



## AFCNX-2

### Extra Long Length 2 Flute Necked

Description	Cutting DIA	SHK DIA	LOC	OAL	No of Flutes	Neck LGTHS	Neck DIA	Corner Radius	Uncoated EDP #	ZRN EDP #
AFCNX-21000	1	1	1 1/4	7	2	4 5/8	.955	Square	AMC713952	AMC713953
								0.030	AMC713960	AMC713961
								0.060	AMC713964	AMC713965
								0.090	AMC713968	AMC713969
								0.120	AMC713972	AMC713973
								0.156	AMC713976	AMC713977
								0.190	AMC713980	AMC713981
								0.250	AMC713984	AMC713985
								Ball	AMC713988	AMC713989

• = In-Stock

Lead Times for non-stock EDP Numbers are 6 working days for uncoated tools and 8 working days for coated tools.

# AFCNS-3

## Standard Length 3 Flute Necked



Description	Cutting DIA	SHK DIA	LOC	OAL	No of Flutes	Neck LGTHS	Neck DIA	Corner Radius	Uncoated EDP #	ZRN EDP #
AFCNS-30250	1/4	1/4	3/8	4	3	1 1/2	.236	Square	• AMC715102	AMC715103
								0.015	• AMC715106	AMC715107
								0.030	AMC715110	AMC715111
								0.060	AMC715114	AMC715115
								0.090	AMC715118	AMC715119
								Ball	• AMC715138	AMC715139
AFCNS-30375	3/8	3/8	1/2	4	3	1 3/4	.355	Square	• AMC715202	AMC715203
								0.015	• AMC715206	AMC715207
								0.030	AMC715210	AMC715211
								0.060	AMC715214	AMC715215
								0.090	AMC715218	AMC715219
								0.120	AMC715222	AMC715223
AFCNS-30500	1/2	1/2	5/8	4	3	2 1/8	.470	Square	• AMC715302	AMC715303
								0.015	• AMC715306	AMC715307
								0.030	AMC715310	AMC715311
								0.060	• AMC715314	AMC715315
								0.090	• AMC715318	AMC715319
								0.120	AMC715322	AMC715323
AFCNS-30625	5/8	5/8	3/4	4	3	2 1/8	.600	Square	• AMC715402	AMC715403
								0.030	• AMC715410	AMC715411
								0.060	• AMC715414	AMC715415
								0.090	• AMC715418	AMC715419
								0.120	• AMC715422	AMC715423
								0.156	AMC715426	AMC715427
AFCNS-30750	3/4	3/4	1	4	3	2 1/8	.715	Square	• AMC715502	AMC715503
								0.030	• AMC715510	AMC715511
								0.060	• AMC715514	AMC715515
								0.090	• AMC715518	AMC715519
								0.120	• AMC715522	AMC715523
								0.156	AMC715526	AMC715527
AFCNS-31000	1	1	1 1/4	5	3	2 1/8	.955	Square	• AMC715602	AMC715603
								0.030	• AMC715610	AMC715611
								0.060	• AMC715614	AMC715615
								0.090	• AMC715618	AMC715619
								0.120	• AMC715622	AMC715623
								0.156	AMC715626	AMC715627
								Square	• AMC715630	AMC715631
								0.190	AMC715634	AMC715635
								0.250	AMC715638	AMC715639
								Ball	• AMC715638	AMC715639

• = In-Stock

Lead Times for non-stock EDP Numbers are 6 working days for uncoated tools and 8 working days for coated tools.



# AFCNM-3

## Medium Length 3 Flute Necked

Aluminum 3 Flute Coolant Through

Description	Cutting DIA	SHK DIA	LOC	OAL	No of Flutes	Neck LGTHS	Neck DIA	Corner Radius	Uncoated EDP #	ZRN EDP #
AFCNM-30250	1/4	1/4	3/8	4	3	1 3/4	.236	Square	• AMC715752	AMC715753
								0.015	• AMC715756	AMC715757
								0.030	AMC715760	AMC715761
								0.060	AMC715764	AMC715765
								0.090	AMC715768	AMC715769
								Ball	• AMC715788	AMC715789
AFCNM-30375	3/8	3/8	1/2	4	3	2 1/4	.355	Square	• AMC715852	AMC715853
								0.015	• AMC715856	AMC715857
								0.030	AMC715860	AMC715861
								0.060	AMC715864	AMC715865
								0.090	AMC715868	AMC715869
								0.120	AMC715872	AMC715873
								0.156	AMC715876	AMC715877
								Ball	• AMC715888	AMC715889
AFCNM-30500	1/2	1/2	5/8	5	3	3 1/8	.470	Square	• AMC715952	AMC715953
								0.015	• AMC715956	AMC715957
								0.030	AMC715960	AMC715961
								0.060	• AMC715964	AMC715965
								0.090	• AMC715968	AMC715969
								0.120	AMC715972	AMC715973
								0.156	AMC715976	AMC715977
								0.190	AMC715980	AMC715981
								Ball	• AMC715988	AMC715989
AFCNM-30625	5/8	5/8	3/4	6	3	3 1/8	.600	Square	• AMC716052	AMC716053
								0.030	• AMC716060	AMC716061
								0.060	• AMC716064	AMC716065
								0.090	• AMC716068	AMC716069
								0.120	• AMC716072	AMC716073
								0.156	AMC716076	AMC716077
								0.190	AMC716080	AMC716081
								0.250	AMC716084	AMC716085
Ball	• AMC716088	AMC716089								
AFCNM-30750	3/4	3/4	1	6	3	3 1/8	.715	Square	• AMC716152	AMC716153
								0.030	• AMC716160	AMC716161
								0.060	• AMC716164	AMC716165
								0.090	• AMC716168	AMC716169
								0.120	• AMC716172	AMC716173
								0.156	AMC716176	AMC716177
								0.190	AMC716180	AMC716181
								0.250	AMC716184	AMC716185
Ball	• AMC716188	AMC716189								
AFCNM-31000	1	1	1 1/4	6	3	3 1/8	.955	Square	• AMC716252	AMC716253
								0.030	• AMC716260	AMC716261
								0.060	• AMC716264	AMC716265
								0.090	• AMC716268	AMC716269
								0.120	• AMC716272	AMC716273
								0.156	AMC716276	AMC716277
								0.190	AMC716280	AMC716281
								0.250	AMC716284	AMC716285
Ball	• AMC716288	AMC716289								

• = In-Stock

Lead Times for non-stock EDP Numbers are 6 working days for uncoated tools and 8 working days for coated tools.

# AFCNL-3

## Long Length 3 Flute Necked



Description	Cutting DIA	SHK DIA	LOC	OAL	No of Flutes	Neck LGTHS	Neck DIA	Corner Radius	Uncoated EDP #	ZRN EDP #
AFCNL-30250	1/4	1/4	3/8	4	3	2 1/8	.236	Square	• AMC716402	AMC716403
								0.015	• AMC716406	AMC716407
								0.030	AMC716410	AMC716411
								0.060	AMC716414	AMC716415
								0.090	AMC716418	AMC716419
								Ball	• AMC716438	AMC716439
AFCNL-30375	3/8	3/8	1/2	5	3	2 3/4	.355	Square	• AMC716502	AMC716503
								0.015	• AMC716506	AMC716507
								0.030	AMC716510	AMC716511
								0.060	AMC716514	AMC716515
								0.090	AMC716518	AMC716519
								0.120	AMC716522	AMC716523
								0.156	AMC716526	AMC716527
								Ball	• AMC716538	AMC716539
AFCNL-30500	1/2	1/2	5/8	6	3	4 1/8	.470	Square	• AMC716602	AMC716603
								0.015	• AMC716606	AMC716607
								0.030	AMC716610	AMC716611
								0.060	AMC716614	AMC716615
								0.090	AMC716618	AMC716619
								0.120	AMC716622	AMC716623
								0.156	AMC716626	AMC716627
								0.190	AMC716630	AMC716631
								Ball	• AMC716638	AMC716639
								AFCNL-30625	5/8	5/8
0.030	• AMC716710	AMC716711								
0.060	AMC716714	AMC716715								
0.090	AMC716718	AMC716719								
0.120	• AMC716722	AMC716723								
0.156	AMC716726	AMC716727								
0.190	• AMC716730	AMC716731								
0.250	AMC716734	AMC716735								
Ball	• AMC716738	AMC716739								
AFCNL-30750	3/4	3/4	1	6	3	4 1/8	.715			
								0.030	• AMC716810	AMC716811
								0.060	AMC716814	AMC716815
								0.090	AMC716818	AMC716819
								0.120	• AMC716822	AMC716823
								0.156	AMC716826	AMC716827
								0.190	• AMC716830	AMC716831
								0.250	AMC716834	AMC716835
								Ball	• AMC716838	AMC716839
								AFCNL-31000	1	1
0.030	• AMC716910	AMC716911								
0.060	• AMC716914	AMC716915								
0.090	AMC716918	AMC716919								
0.120	• AMC716922	AMC716923								
0.156	AMC716926	AMC716927								
0.190	• AMC716930	AMC716931								
0.250	AMC716934	AMC716935								
Ball	• AMC716938	AMC716939								

• = In-Stock

Lead Times for non-stock EDP Numbers are 6 working days for uncoated tools and 8 working days for coated tools.





# AFCNX-3

## Extra Long Length 3 Flute Necked

Description	Cutting DIA	SHK DIA	LOC	OAL	No of Flutes	Neck LGTHS	Neck DIA	Corner Radius	Uncoated EDP #	ZRN EDP #
AFCNX-31000	1	1	1 1/4	7	3	4 5/8	.955	Square	AMC716952	AMC716953
								0.030	AMC716960	AMC716961
								0.060	AMC716964	AMC716965
								0.090	AMC716968	AMC716969
								0.120	AMC716972	AMC716973
								0.156	AMC716976	AMC716977
								0.190	AMC716980	AMC716981
								0.250	AMC716984	AMC716985
								Ball	AMC716988	AMC716989

• = In-Stock

Lead Times for non-stock EDP Numbers are 6 working days for uncoated tools and 8 working days for coated tools.

# AR & ARC SERIES TECHNICAL DATA FOR ALUMINUM ROUGHERS

**NEW**

## Remove Material 30% Faster With Onsrud's 2 & 3 Flute High-Performance Roughers

LMT Onsrud Aluminum Roughers are designed for heavy metal removal rates. The ground in chipbreaker pattern and open flute geometry are optimized to slot 30% faster than our standard AF Series. Utilize the ARC End mills for improved chip evacuation and longer tool life.

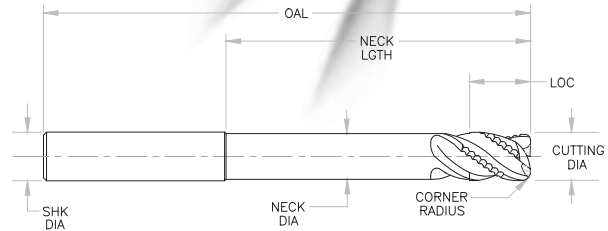

### CHIP LOAD PER TOOTH

Material/Grade	AR Series					
	Power Factor	SFM	3/8	1/2	3/4	1
<b>Aluminum 6061/7075</b>	4	500/1500				
Slotting			0.0073	0.0097	0.0145	0.0194
<b>Brass/Bronze</b>	8	500/900				
Slotting			0.0061	0.0086	0.0122	0.0163
<b>Copper Alloys</b>	2	700/1000				
Slotting			0.0061	0.0086	0.0122	0.0163
<b>Magnesium</b>	4	500/900				
Slotting			0.0061	0.0086	0.0122	0.0163

### CHIP LOAD PER TOOTH

Material/Grade	ARC Series					
	Power Factor	SFM	3/8	1/2	3/4	1
<b>Aluminum 6061/7075</b>	4	500/1500				
Slotting			0.0091	0.0121	0.0181	0.0243
<b>Brass/Bronze</b>	8	500/900				
Slotting			0.0076	0.0108	0.0153	0.0204
<b>Copper Alloys</b>	2	700/1000				
Slotting			0.0076	0.0108	0.0153	0.0204
<b>Magnesium</b>	4	500/900				
Slotting			0.0076	0.0108	0.0153	0.0204



## AR-2 2 Flute

Description	Cutting DIA	SHK DIA	LOC	OAL	No of Flutes	Neck LGTHS	Neck DIA	Corner Radius	ZRN EDP #
ARS-20375	3/8	3/8	1/2	3	2	-	-	0.030	• AMC800003
ARNS-20375	3/8	3/8	1/2	4	2	1 5/8	0.355	0.030	• AMC800011
ARS-20500	1/2	1/2	5/8	3	2	-	-	0.030	• AMC800005
ARNS-20500	1/2	1/2	5/8	4	2	2 1/8	0.470	0.030	• AMC800013
	1/2	1/2	5/8	4	2	2 1/8	0.470	0.060	AMC800015
ARNM-20500	1/2	1/2	5/8	5	2	3 1/8	0.470	0.030	• AMC800025
	1/2	1/2	5/8	5	2	3 1/8	0.470	0.060	AMC800027
ARNL-20500	1/2	1/2	5/8	6	2	4 1/8	0.470	0.030	AMC800035
	1/2	1/2	5/8	6	2	4 1/8	0.470	0.060	AMC800037
ARS-20750	3/4	3/4	1	4	2	-	-	0.060	• AMC800007
ARNS-20750	3/4	3/4	1	4	2	2 1/8	0.715	0.060	• AMC800017
	3/4	3/4	1	4	2	2 1/8	0.715	0.120	• AMC800019
ARNM-20750	3/4	3/4	1	6	2	3 1/8	0.715	0.060	• AMC800029
	3/4	3/4	1	6	2	3 1/8	0.715	0.120	AMC800031
ARNL-20750	3/4	3/4	1	6	2	4 1/8	0.715	0.060	AMC800039
	3/4	3/4	1	6	2	4 1/8	0.715	0.120	AMC800041
ARS-21000	1	1	1 1/4	4	2	-	-	0.060	• AMC800009
ARNS-21000	1	1	1 1/4	5	2	2 1/8	0.955	0.060	• AMC800021
	1	1	1 1/4	5	2	2 1/8	0.955	0.120	AMC800023
ARNM-21000	1	1	1 1/4	6	2	3 1/8	0.955	0.120	• AMC800033
ARNL-21000	1	1	1 1/4	7	2	4 1/8	0.955	0.120	AMC800043

• = In-Stock

Lead Times for non-stock EDP Numbers are 6 working days for uncoated tools and 8 working days for coated tools.

# AR-3

## 3 Flute



Description	Cutting DIA	SHK DIA	LOC	OAL	No of Flutes	Neck LGTHS	Neck DIA	Corner Radius	ZRN EDP #
ARS-30375	3/8	3/8	1/2	3	3	-	-	0.030	• AMC800103
ARNS-30375	3/8	3/8	1/2	4	3	1 5/8	0.355	0.030	• AMC800111
ARS-30500	1/2	1/2	5/8	3	3	-	-	0.030	• AMC800105
ARNS-30500	1/2	1/2	5/8	4	3	2 1/8	0.470	0.030	• AMC800113
	1/2	1/2	5/8	4	3	2 1/8	0.470	0.060	AMC800115
ARNM-30500	1/2	1/2	5/8	5	3	3 1/8	0.470	0.030	• AMC800125
	1/2	1/2	5/8	5	3	3 1/8	0.470	0.060	AMC800127
ARNL-30500	1/2	1/2	5/8	6	3	4 1/8	0.470	0.030	AMC800135
	1/2	1/2	5/8	6	3	4 1/8	0.470	0.060	AMC800137
ARS-30750	3/4	3/4	1	4	3	-	-	0.060	• AMC800107
ARNS-30750	3/4	3/4	1	4	3	2 1/8	0.715	0.060	• AMC800117
	3/4	3/4	1	4	3	2 1/8	0.715	0.120	• AMC800119
ARNM-30750	3/4	3/4	1	6	3	3 1/8	0.715	0.060	• AMC800129
	3/4	3/4	1	6	3	3 1/8	0.715	0.120	AMC800131
ARNL-30750	3/4	3/4	1	6	3	4 1/8	0.715	0.060	AMC800139
	3/4	3/4	1	6	3	4 1/8	0.715	0.120	AMC800141
ARS-31000	1	1	1 1/4	4	3	-	-	0.060	• AMC800109
ARNS-31000	1	1	1 1/4	5	3	2 1/8	0.955	0.060	• AMC800121
	1	1	1 1/4	5	3	2 1/8	0.955	0.120	AMC800123
ARNM-31000	1	1	1 1/4	6	3	3 1/8	0.955	0.120	• AMC800133
ARNL-31000	1	1	1 1/4	7	3	4 1/8	0.955	0.120	AMC800143

• = In-Stock

Lead Times for non-stock EDP Numbers are 6 working days for uncoated tools and 8 working days for coated tools.



## ARC-2 2 Flute

Description	Cutting DIA	SHK DIA	LOC	OAL	No of Flutes	Neck LGTHS	Neck DIA	Corner Radius	ZRN EDP #
ARCS-20375	3/8	3/8	1/2	3	2	-	-	0.030	• AMC800045
ARCS-20500	1/2	1/2	5/8	3	2	-	-	0.030	• AMC800047
ARCNS-20500	1/2	1/2	5/8	4	2	2 1/8	0.470	0.030	• AMC800053
	1/2	1/2	5/8	4	2	2 1/8	0.470	0.060	AMC800055
ARCNM-20500	1/2	1/2	5/8	5	2	3 1/8	0.470	0.030	• AMC800065
	1/2	1/2	5/8	5	2	3 1/8	0.470	0.060	AMC800067
ARCNL-20500	1/2	1/2	5/8	6	2	4 1/8	0.470	0.030	AMC800075
	1/2	1/2	5/8	6	2	4 1/8	0.470	0.060	AMC800077
ARCS-20750	3/4	3/4	1	4	2	-	-	0.060	• AMC800049
ARCNS-20750	3/4	3/4	1	4	2	2 1/8	0.715	0.060	• AMC800057
	3/4	3/4	1	4	2	2 1/8	0.715	0.120	AMC800059
ARCNM-20750	3/4	3/4	1	6	2	3 1/8	0.715	0.060	• AMC800069
	3/4	3/4	1	6	2	3 1/8	0.715	0.120	AMC800071
ARCNL-20750	3/4	3/4	1	6	2	4 1/8	0.715	0.060	AMC800079
	3/4	3/4	1	6	2	4 1/8	0.715	0.120	AMC800081
ARCS-21000	1	1	1 1/4	4	2	-	-	0.060	• AMC800051
ARCNS-21000	1	1	1 1/4	5	2	2 1/8	0.955	0.060	• AMC800061
	1	1	1 1/4	5	2	2 1/8	0.955	0.120	AMC800063
ARCNM-21000	1	1	1 1/4	6	2	3 1/8	0.955	0.120	• AMC800073
ARCNL-21000	1	1	1 1/4	7	2	4 1/8	0.955	0.120	AMC800083

• = In-Stock

Lead Times for non-stock EDP Numbers are 6 working days for uncoated tools and 8 working days for coated tools.

# ARC-3

## 3 Flute

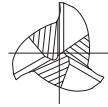

Description	Cutting DIA	SHK DIA	LOC	OAL	No of Flutes	Neck LGTHS	Neck DIA	Corner Radius	ZRN EDP #
ARCS-30375	3/8	3/8	1/2	3	3	-	-	0.030	• AMC800145
ARCS-30500	1/2	1/2	5/8	3	3	-	-	0.030	• AMC800147
ARCNS-30500	1/2	1/2	5/8	4	3	2 1/8	0.470	0.030	• AMC800153
	1/2	1/2	5/8	4	3	2 1/8	0.470	0.060	AMC800155
ARCNM-30500	1/2	1/2	5/8	5	3	3 1/8	0.470	0.030	• AMC800165
	1/2	1/2	5/8	5	3	3 1/8	0.470	0.060	AMC800167
ARCNL-30500	1/2	1/2	5/8	6	3	4 1/8	0.470	0.030	AMC800175
	1/2	1/2	5/8	6	3	4 1/8	0.470	0.060	AMC800177
ARCS-30750	3/4	3/4	1	4	3	-	-	0.060	• AMC800149
ARCNS-30750	3/4	3/4	1	4	3	2 1/8	0.715	0.060	• AMC800157
	3/4	3/4	1	4	3	2 1/8	0.715	0.120	AMC800159
ARCNM-30750	3/4	3/4	1	6	3	3 1/8	0.715	0.060	• AMC800169
	3/4	3/4	1	6	3	3 1/8	0.715	0.120	AMC800171
ARCNL-30750	3/4	3/4	1	6	3	4 1/8	0.715	0.060	AMC800179
	3/4	3/4	1	6	3	4 1/8	0.715	0.120	AMC800181
ARCS-31000	1	1	1 1/4	4	3	-	-	0.060	• AMC800151
ARCNS-31000	1	1	1 1/4	5	3	2 1/8	0.955	0.060	• AMC800161
	1	1	1 1/4	5	3	2 1/8	0.955	0.120	AMC800163
ARCNM-31000	1	1	1 1/4	6	3	3 1/8	0.955	0.120	• AMC800173
ARCNL-31000	1	1	1 1/4	7	3	4 1/8	0.955	0.120	• AMC800183

• = In-Stock

Lead Times for non-stock EDP Numbers are 6 working days for uncoated tools and 8 working days for coated tools.

# TV & TF Series High Performance End Mills

for Exotic Metals  
& Stainless Steels

LMT Onsrud's broad offering of High Performance End Mills for Exotic Metals & Stainless Steels feature the TV Series for versatility in slotting, roughing and semi-finishing and the TF Series for superior finishing.

LMT Onsrud tools maximize output of your spindle while producing accurate and quality parts. Features such as variable flute indexing, rigid tool design, and built-in dampening effects increase productivity in various Exotic Metals & Stainless Steels.

LMT Onsrud will further enhance your productivity by offering as standard tools the industry's largest selection of corner radii and neck and flute lengths.

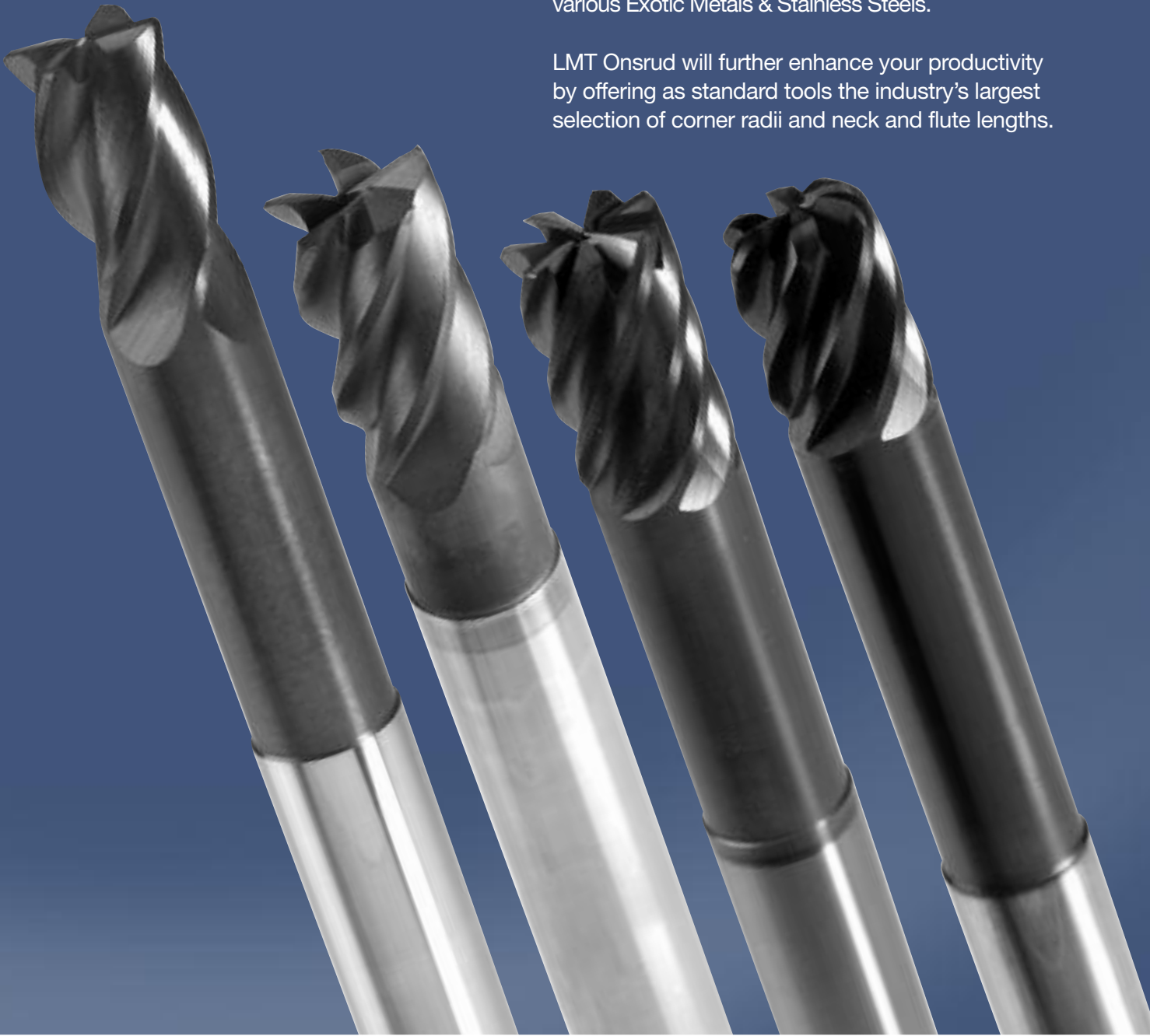

**LMT ONSRUD**



# TV-4 SERIES TECHNICAL DATA FOR EXOTIC METAL END MILLS

## Get the Most Versatility with Onsrud's 4 Flute High-Performance End Mills

The TV-4 Series End Mills are able to achieve high metal removal rates due to variable flute indexing that reduces cutting forces and likeliness of chatter. Longer length tools incorporate a large core diameter that further prevents chatter caused by deflection. Tools range from square to full ball nose to meet aerospace industry requirements.

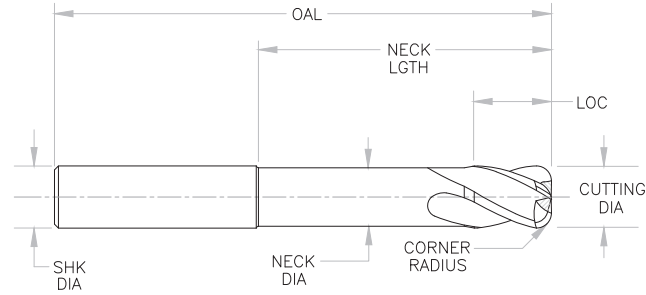

### CHIP LOAD PER TOOTH

Material/Grade	SFM	1/8	3/16	1/4	5/16	3/8	1/2	5/8	3/4	1
<b>Titanium</b>										
5553 Slotting	60 - 220	.0007	.0010	.0014	.0017	.0021	.0028	.0035	.0042	.0056
6Al-4V Profiling 33% RDoC		.0009	.0014	.0018	.0022	.0027	.0036	.0044	.0053	.0072
Commercially Pure										
<b>Cobalt Base</b>										
Haynes 21/26 Slotting	40 - 100	.0005	.0010	.001	.0012	.0014	.002	.0026	.0031	.004
NASA CO-W-RE Profiling 33% RDoC		.0006	.0009	.0012	.0014	.0018	.0026	.0031	.0038	.005
Stellite										
<b>Iron Base</b>										
A-286, Discoly Slotting	50 - 100	.0006	.0009	.0012	.0017	.0021	.0025	.0031	.0038	.005
Incoly, Multimet Profiling 33% RDoC		.0007	.0010	.0014	.0022	.0025	.003	.0038	.0045	.006
Timken 16-25-6										
<b>Nickel Base</b>										
Hastalloy, Waspalloy Slotting	40 - 100	.0005	.0008	.001	.0012	.0014	.002	.0026	.0031	.004
Rene 41-95, Monel Profiling 33% RDoC		.0006	.0009	.0012	.0014	.0018	.0026	.0031	.0038	.005
Inconel 625, 718										
<b>Austenitic Stainless</b>										
304, 310, 314 Slotting	100 - 350	.00065	.0009	.0013	.0017	.0021	.0028	.0035	.0042	.0056
316L Profiling 33% RDoC		.00085	.0010	.0017	.0021	.0027	.0036	.0044	.0053	.0072
302, 304L										
<b>Precipitation Stainless</b>										
13-8PH, 15-5PH Slotting	90 - 250	.0007	.0010	.0014	.0017	.0021	.0028	.0035	.0042	.0056
17-4PH Profiling 33% RDoC		.0009	.0014	.0018	.0022	.0027	.0036	.0044	.0053	.0072
<b>Martensitic Stainless</b>										
420, 430F, 440 Slotting	100 - 250	.0007	.0010	.0014	.0017	.0021	.0028	.0035	.0042	.0056
403, 410, 416 Profiling 33% RDoC		.0009	.0014	.0018	.0022	.0027	.0036	.0044	.0053	.0072
<b>Carbon Steels</b>										
10XX, 11XX, Slotting	400 / 600	.0007	.0011	.0014	.0018	.0021	.0028	.0035	.0042	.0056
13XX, 15XX Profiling 33%		.0009	.0015	.0018	.0023	.0027	.0036	.0044	.0053	.0072
<b>Alloy Steels</b>										
4140, 4340, Slotting	250/450	.0007	.0011	.0014	.0018	.0021	.0028	.0035	.0042	.0056
200, 250, 300 Profiling 33%		.0009	.0015	.0018	.0023	.0027	.0036	.0044	.0053	.0072
<b>Mold &amp; Die Steel</b>										
A2, D2, 01, Slotting	150 / 250	.0007	.0011	.0014	.0018	.0021	.0028	.0035	.0042	.0056
H-13, S7 Profiling 33%		.0009	.0015	.0018	.0023	.0027	.0036	.0044	.0053	.0072



# TVS-4

## Standard Length

Description	Cutting DIA	SHK DIA	LOC	OAL	No of Flutes	Corner Radius	Coated EDP #
TVS-40125	1/8	1/8	1/4	2	4	Square	• EMC400002
						0.010	EMC400004
						Ball	• EMC400006
TVS-40188	3/16	3/16	5/16	2	4	Square	• EMC400008
						0.010	EMC400010
						Ball	• EMC400012
TVS-40250	1/4	1/4	3/8	2	4	Square	• EMC601604
						0.015	• EMC601734
						0.030	• EMC601624
						0.060	EMC601640
						0.090	EMC601656
TVS-40313	5/16	5/16	9/16	2 1/2	4	Square	• EMC400014
						0.015	EMC400016
						Ball	• EMC400018
TVS-40375	3/8	3/8	1/2	2	4	Square	• EMC601608
						0.015	• EMC601738
						0.030	• EMC601628
						0.060	• EMC601644
						0.090	• EMC601660
						0.120	• EMC601672
						0.156	EMC601684
TVS-40500	1/2	1/2	5/8	2 1/2	4	Square	• EMC601612
						0.015	• EMC601742
						0.030	• EMC601632
						0.060	• EMC601648
						0.090	• EMC601664
						0.120	• EMC601676
						0.156	EMC601688
TVS-40625	5/8	5/8	3/4	3	4	Square	• EMC601614
						0.030	• EMC601634
						0.060	• EMC601650
						0.090	• EMC601666
						0.120	EMC601678
						0.156	EMC601690
						0.190	EMC601698
TVS-40750	3/4	3/4	1 1/8	3	4	Square	• EMC601616
						0.030	• EMC601636
						0.060	• EMC601652
						0.090	• EMC601668
						0.120	• EMC601680
						0.156	EMC601692
						0.190	EMC601700
TVS-41000	1	1	1 1/4	3	4	Square	EMC601618
						0.030	• EMC601638
						0.060	• EMC601654
						0.090	• EMC601670
						0.120	• EMC601682
						0.156	EMC601694
						0.190	EMC601702
						0.250	• EMC601708
						Ball	• EMC601728

• = In-Stock

Lead Times for non-stock EDP Numbers are 6 working days for uncoated tools and 8 working days for coated tools.

# TVM-4

## Medium Length



Description	Cutting DIA	SHK DIA	LOC	OAL	No of Flutes	Corner Radius	Coated EDP #
TVM-40125	1/8	1/8	1/2	2 1/2	4	Square	• EMC400020
						0.010	EMC400022
						Ball	• EMC400024
TVM-40188	3/16	3/16	5/8	2 1/2	4	Square	• EMC400026
						0.010	EMC400028
						Ball	• EMC400030
TVM-40250	1/4	1/4	3/4	2 1/2	4	Square	• EMC601904
						0.015	• EMC602034
						0.030	• EMC601924
						0.060	EMC601940
						0.090	EMC601956
						Ball	• EMC602014
TVM-40313	5/16	5/16	13/16	2 1/2	4	Square	• EMC400032
						0.015	EMC400034
						Ball	• EMC400036
TVM-40375	3/8	3/8	1 1/8	2 1/2	4	Square	• EMC601908
						0.015	• EMC602038
						0.030	• EMC601928
						0.060	• EMC601944
						0.090	• EMC601960
						0.120	• EMC601972
						0.156	EMC601984
Ball	• EMC602018						
TVM-40500	1/2	1/2	1 1/4	3	4	Square	• EMC601912
						0.015	• EMC602042
						0.030	• EMC601932
						0.060	• EMC601948
						0.090	• EMC601964
						0.120	• EMC601976
						0.156	EMC601988
0.190	• EMC601996						
Ball	• EMC602022						
TVM-40625	5/8	5/8	1 5/8	3 1/2	4	Square	• EMC601914
						0.030	• EMC601934
						0.060	• EMC601950
						0.090	• EMC601966
						0.120	• EMC601978
						0.156	EMC601990
						0.190	EMC601998
0.250	EMC602004						
Ball	• EMC602024						
TVM-40750	3/4	3/4	1 5/8	4	4	Square	• EMC601916
						0.030	• EMC601936
						0.060	• EMC601952
						0.090	• EMC601968
						0.120	• EMC601980
						0.156	EMC601992
						0.190	• EMC602000
0.250	• EMC602006						
Ball	• EMC602026						
TVM-41000	1	1	2	4	4	Square	EMC601918
						0.030	• EMC601938
						0.060	• EMC601954
						0.090	• EMC601970
						0.120	• EMC601982
						0.156	EMC601994
						0.190	EMC602002
0.250	• EMC602008						
Ball	• EMC602028						



# TVNS-4

## Standard Length Necked

Description	Cutting DIA	SHK DIA	LOC	OAL	No of Flutes	Neck LGTHS	Neck DIA	Corner Radius	Coated EDP #
TVNS-40250	1/4	1/4	3/8	4	4	2 1/8	.236	Square	• EMC602504
								0.015	• EMC602616
								0.030	• EMC602522
								0.060	EMC602536
								0.090	EMC602550
								Ball	• EMC602604
TVNS-40375	3/8	3/8	1/2	4	4	2 1/4	.355	Square	• EMC602508
								0.015	• EMC602620
								0.030	• EMC602526
								0.060	• EMC602540
								0.090	• EMC602554
								0.120	• EMC602564
0.156	EMC602574								
Ball	• EMC602584								
TVNS-40500	1/2	1/2	5/8	4	4	2 3/8	.470	Square	• EMC602512
								0.015	• EMC602624
								0.030	• EMC602530
								0.060	• EMC602544
								0.090	• EMC602558
								0.120	• EMC602568
0.156	EMC602578								
0.190	• EMC602590								
Ball	• EMC602588								
TVNS-40625	5/8	5/8	3/4	4	4	2 3/8	0.593	Square	• EMC602632
								0.030	• EMC602634
								0.060	• EMC602636
								0.090	• EMC602638
								0.120	EMC602640
								0.156	EMC602642
0.190	EMC602644								
0.250	EMC602646								
Ball	• EMC602648								
TVNS-40750	3/4	3/4	1 1/8	4	4	2 1/2	.715	Square	• EMC602514
								0.030	• EMC602532
								0.060	• EMC602546
								0.090	• EMC602560
								0.120	• EMC602570
								0.156	EMC602580
0.190	EMC602592								
0.250	• EMC602596								
Ball	• EMC602608								
TVNS-41000	1	1	1 1/4	5	4	2 1/2	.955	Square	EMC602516
								0.030	• EMC602534
								0.060	• EMC602548
								0.090	• EMC602562
								0.120	• EMC602572
								0.156	EMC602582
0.190	EMC602594								
0.250	• EMC602598								
Ball	• EMC602610								

• = In-Stock

Lead Times for non-stock EDP Numbers are 6 working days for uncoated tools and 8 working days for coated tools.

# TVNM-4

## Medium Length Necked



Description	Cutting DIA	SHK DIA	LOC	OAL	No of Flutes	Neck LGTHS	Neck DIA	Corner Radius	Coated EDP #
TVNM-40250	1/4	1/4	3/8	4	4	2 1/2	.236	Square	• EMC602804
								0.015	• EMC602916
								0.030	• EMC602822
								0.060	EMC602836
								0.090	EMC602850
								Ball	• EMC602898
TVNM-40375	3/8	3/8	1/2	4	4	2 5/8	.355	Square	• EMC602808
								0.015	• EMC602920
								0.030	• EMC602826
								0.060	• EMC602840
								0.090	• EMC602854
								0.120	• EMC602864
TVNM-40500	1/2	1/2	5/8	6	4	3 1/8	.470	Square	• EMC602812
								0.015	• EMC602924
								0.030	• EMC602830
								0.060	• EMC602844
								0.090	• EMC602858
								0.120	• EMC602868
TVNM-40625	5/8	5/8	3/4	6	4	3 1/8	0.593	Square	• EMC602932
								0.030	• EMC602934
								0.060	• EMC602936
								0.090	• EMC602938
								0.120	EMC602940
								0.156	EMC602942
TVNM-40750	3/4	3/4	1 1/8	6	4	3 1/8	.715	Square	• EMC602814
								0.030	• EMC602832
								0.060	• EMC602846
								0.090	• EMC602860
								0.120	• EMC602870
								0.156	EMC602880
TVNM-41000	1	1	1 1/4	6	4	3 1/8	.955	Square	EMC602816
								0.030	EMC602834
								0.060	• EMC602848
								0.090	• EMC602862
								0.120	• EMC602872
								0.156	EMC602882
								0.190	EMC602888
								0.250	• EMC602892
								Ball	• EMC602910

• = In-Stock

Lead Times for non-stock EDP Numbers are 6 working days for uncoated tools and 8 working days for coated tools.

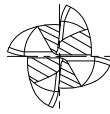

## TVNL-4 Long Length Necked

Description	Cutting DIA	SHK DIA	LOC	OAL	No of Flutes	Neck LGTHS	Neck DIA	Corner Radius	Coated EDP #
TVNL-40250	1/4	1/4	3/8	4	4	3 1/8	.236	Square	EMC603204
								0.015	EMC603316
								0.030	• EMC603222
								0.060	EMC603236
								0.090	EMC603250
								Ball	• EMC603298
TVNL-40375	3/8	3/8	1/2	6	4	3 1/4	.355	Square	EMC603208
								0.015	EMC603320
								0.030	• EMC603226
								0.060	EMC603240
								0.090	EMC603254
								0.120	EMC603264
TVNL-40500	1/2	1/2	5/8	6	4	4 1/8	.470	Square	EMC603212
								0.015	EMC603324
								0.030	EMC603230
								0.060	EMC603244
								0.090	EMC603258
								0.120	• EMC603268
TVNL-40625	5/8	5/8	3/4	6	4	4 1/8	.593	Square	EMC603332
								0.030	EMC603334
								0.060	EMC603336
								0.090	EMC603338
								0.120	EMC603340
								0.156	EMC603342
TVNL-40750	3/4	3/4	1 1/8	6	4	4 1/8	.715	Square	EMC603214
								0.030	EMC603232
								0.060	• EMC603246
								0.090	EMC603260
								0.120	• EMC603270
								0.156	EMC603280
TVNL-41000	1	1	1 1/4	7	4	4 1/8	.955	Square	EMC603216
								0.030	EMC603234
								0.060	EMC603248
								0.090	EMC603262
								0.120	• EMC603272
								0.156	EMC603282
								0.190	• EMC603288
								0.250	• EMC603292
								Ball	• EMC603310

• = In-Stock

Lead Times for non-stock EDP Numbers are 6 working days for uncoated tools and 8 working days for coated tools.

Exotic Metals 4 Flute Necked

# TV-5 SERIES TECHNICAL DATA FOR EXOTIC METAL END MILLS

## Slot, Profile and Semi-Finish with Onsrud's 5 Flute High-Performance End Mills



Increase feed rates 20% over 4 flute tools. Variable flute indexing reduces chatter. Largest selection of aerospace specific corner radii. Manufactured with highest transverse rupture strength, premium grade carbide. Combine Onsrud's 5 Flute TV series with 10 Flute finishers and watch your profits SOAR!

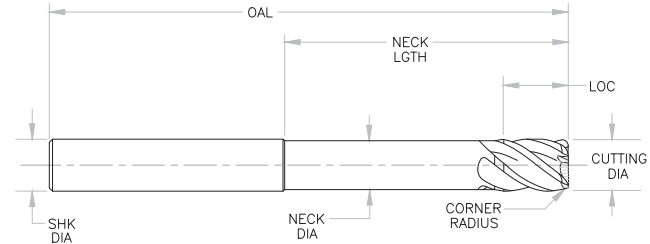

### CHIP LOAD PER TOOTH

Material/Grade	SFM	1/8	3/16	1/4	5/16	3/8	1/2	5/8	3/4	1
<b>Titanium</b>										
5553 Slotting	60 - 220	.0007	.0010	.0014	.0017	.0021	.0028	.0035	.0042	.0056
6Al-4V Profiling 33% RDoC		.0009	.0014	.0018	.0022	.0027	.0036	.0044	.0053	.0072
Commercially Pure										
<b>Cobalt Base</b>										
Haynes 21/26 Slotting	40 - 100	.0005	.0010	.001	.0012	.0014	.002	.0026	.0031	.004
NASA CO-W-RE Profiling 33% RDoC		.0006	.0009	.0012	.0014	.0018	.0026	.0031	.0038	.005
Stellite										
<b>Iron Base</b>										
A-286, Discoly Slotting	50 - 100	.0006	.0009	.0012	.0017	.0021	.0025	.0031	.0038	.005
Incoly, Multimet Profiling 33% RDoC		.0007	.0010	.0014	.0022	.0025	.003	.0038	.0045	.006
Timken 16-25-6										
<b>Nickel Base</b>										
Hastalloy, Waspalloy Slotting	40 - 100	.0005	.0008	.001	.0012	.0014	.002	.0026	.0031	.004
Rene 41-95, Monel Profiling 33% RDoC		.0006	.0009	.0012	.0014	.0018	.0026	.0031	.0038	.005
Inconel 625, 718										
<b>Austenitic Stainless</b>										
304, 310, 314 Slotting	100 - 350	.00065	.0009	.0013	.0017	.0021	.0028	.0035	.0042	.0056
316L Profiling 33% RDoC		.00085	.0010	.0017	.0021	.0027	.0036	.0044	.0053	.0072
302, 304L										
<b>Precipitation Stainless</b>										
13-8PH, 15-5PH Slotting	90 - 250	.0007	.0010	.0014	.0017	.0021	.0028	.0035	.0042	.0056
17-4PH Profiling 33% RDoC		.0009	.0014	.0018	.0022	.0027	.0036	.0044	.0053	.0072
<b>Martensitic Stainless</b>										
420, 430F, 440 Slotting	100 - 250	.0007	.0010	.0014	.0017	.0021	.0028	.0035	.0042	.0056
403, 410, 416 Profiling 33% RDoC		.0009	.0014	.0018	.0022	.0027	.0036	.0044	.0053	.0072
<b>Carbon Steels</b>										
10XX, 11XX, Slotting	400 / 600	.0007	.0011	.0014	.0018	.0021	.0028	.0035	.0042	.0056
13XX, 15XX Profiling 33%		.0009	.0015	.0018	.0023	.0027	.0036	.0044	.0053	.0072
<b>Alloy Steels</b>										
4140, 4340, Slotting	250/450	.0007	.0011	.0014	.0018	.0021	.0028	.0035	.0042	.0056
200, 250, 300 Profiling 33%		.0009	.0015	.0018	.0023	.0027	.0036	.0044	.0053	.0072
<b>Mold &amp; Die Steel</b>										
A2, D2, 01, Slotting	150 / 250	.0007	.0011	.0014	.0018	.0021	.0028	.0035	.0042	.0056
H-13, S7 Profiling 33%		.0009	.0015	.0018	.0023	.0027	.0036	.0044	.0053	.0072





# TVS-5

## Standard Length

Description	Cutting DIA	SHK DIA	LOC	OAL	No of Flutes	Corner Radius	AITiN
TVS-50125	1/8	1/8	1/4	2	5	Square	• EMC400038
						.010	EMC400040
						Ball	• EMC400042
TVS-50188	3/16	3/16	5/16	2	5	Square	• EMC400044
						.010	EMC400046
						Ball	• EMC400048
TVS-50250	1/4	1/4	3/8	2	5	Square	• EMC604000
						.015	• EMC604002
						.030	• EMC604004
						.060	EMC604006
						.090	EMC604008
						Ball	• EMC604010
TVS-50313	5/16	5/16	9/16	2 1/2	5	Square	• EMC400050
						.015	EMC400052
						Ball	• EMC400054
TVS-50375	3/8	3/8	1/2	2	5	Square	• EMC604012
						.015	• EMC604014
						.030	• EMC604016
						.060	• EMC604018
						.090	• EMC604020
						.120	• EMC604022
TVS-50500	1/2	1/2	5/8	2 1/2	5	Square	• EMC604024
						.015	• EMC604026
						.030	• EMC604028
						.060	• EMC604030
						.090	• EMC604032
						.120	• EMC604034
						.156	EMC604036
						.190	EMC604038
						.190	• EMC604040
						Ball	• EMC604042
TVS-50625	5/8	5/8	3/4	3	5	Square	• EMC604044
						.030	• EMC604046
						.060	• EMC604048
						.090	• EMC604050
						.120	EMC604052
						.156	EMC604054
						.190	EMC604056
						.250	EMC604058
TVS-50750	3/4	3/4	1 1/8	3	5	Square	• EMC604060
						.030	• EMC604062
						.060	• EMC604064
						.090	• EMC604066
						.120	• EMC604068
						.120	EMC604070
						.156	EMC604072
						.190	EMC604074
						.250	• EMC604076
						Ball	• EMC604078
TVS-51000	1	1	1 1/4	4	5	Square	EMC604080
						.030	• EMC604082
						.060	• EMC604084
						.090	• EMC604086
						.120	• EMC604088
						.156	EMC604090
						.190	EMC604092
						.250	• EMC604094
Ball	• EMC604096						

• = In-Stock

Lead Times for non-stock EDP Numbers are 6 working days for uncoated tools and 8 working days for coated tools.

# TVM-5

## Medium Length



Description	Cutting DIA	SHK DIA	LOC	OAL	No of Flutes	Corner Radius	AITIN
TVM-50125	1/8	1/8	1/2	2 1/2	5	Square	• EMC400056
						.010	EMC400058
						Ball	• EMC400060
TVM-50188	3/16	3/16	5/8	2 1/2	5	Square	• EMC400062
						.010	EMC400064
						Ball	• EMC400066
TVM-50250	1/4	1/4	3/4	2 1/2	5	Square	• EMC604100
						.015	• EMC604102
						.030	• EMC604104
						.060	• EMC604106
						.090	EMC604108
						Ball	• EMC604110
TVM-50313	5/16	5/16	13/16	2 1/2	5	Square	• EMC400068
						.015	EMC400070
						Ball	• EMC400072
TVM-50375	3/8	3/8	1 1/8	2 1/2	5	Square	• EMC604112
						.015	• EMC604114
						.030	• EMC604116
						.060	• EMC604118
						.090	• EMC604120
						.120	• EMC604122
TVM-50500	1/2	1/2	1 1/4	3	5	Square	• EMC604124
						.015	• EMC604126
						.030	• EMC604128
						.060	• EMC604130
						.090	• EMC604132
						.120	• EMC604134
						.156	EMC604136
						.190	EMC604138
						Ball	• EMC604140
TVM-50625	5/8	5/8	1 5/8	3 1/2	5	Square	• EMC604142
						.030	• EMC604144
						.060	• EMC604146
						.090	• EMC604148
						.120	• EMC604150
						.156	• EMC604152
						.190	EMC604154
						.250	EMC604156
						Ball	EMC604158
TVM-50750	3/4	3/4	1 5/8	4	5	Square	• EMC604160
						.030	• EMC604162
						.060	• EMC604164
						.090	• EMC604166
						.120	• EMC604168
						.156	• EMC604170
						.190	EMC604172
						.250	• EMC604174
						Ball	• EMC604176
TVM-51000	1	1	2	5	5	Square	• EMC604178
						.030	EMC604180
						.060	• EMC604182
						.090	• EMC604184
						.120	• EMC604186
						.156	• EMC604188
						.190	EMC604190
						.250	EMC604192
						Ball	• EMC604194
						• EMC604196	

• = In-Stock

Exotic Metals 5 Flute



## TVNS-5 Standard Length Necked

Description	Cutting DIA	SHK DIA	LOC	OAL	No of Flutes	Neck LGTH	Neck DIA	Corner Radius	AITiN
TVNS-50250	1/4	1/4	3/8	3	5	1 3/8	.236	Square	• EMC604200
								.015	• EMC604202
								.030	• EMC604204
								.060	EMC604206
								.090	EMC604208
								Ball	• EMC604210
TVNS-50375	3/8	3/8	1/2	3	5	1 5/8	.355	Square	• EMC604212
								.015	• EMC604214
								.030	• EMC604216
								.060	• EMC604218
								.090	• EMC604220
								.120	• EMC604222
TVNS-50500	1/2	1/2	5/8	4	5	2 1/8	.470	Square	• EMC604226
								.015	• EMC604228
								.030	• EMC604230
								.060	• EMC604232
								.090	• EMC604234
								.120	• EMC604236
TVNS-50625	5/8	5/8	3/4	5	5	2 3/8	0.593	Square	• EMC604244
								.030	• EMC604246
								.060	• EMC604248
								.090	• EMC604250
								.120	EMC604252
								.156	EMC604254
TVNS-50750	3/4	3/4	1 1/8	5	5	2 5/8	.715	Square	• EMC604262
								.030	• EMC604264
								.060	• EMC604266
								.090	• EMC604268
								.120	• EMC604270
								.156	EMC604272
TVNS-51000	1	1	1 1/4	5	5	2 5/8	.955	Square	EMC604280
								.030	• EMC604282
								.060	• EMC604284
								.090	• EMC604286
								.120	• EMC604288
								.156	EMC604290
								.190	EMC604292
								.250	• EMC604294
								Ball	• EMC604296

• = In-Stock

Lead Times for non-stock EDP Numbers are 6 working days for uncoated tools and 8 working days for coated tools.

# TVNM-5

## Medium Length Necked



Description	Cutting DIA	SHK DIA	LOC	OAL	No of Flutes	Neck LGTH	Neck DIA	Corner Radius	ATTN
TVNM-50250	1/4	1/4	3/8	4	5	1 3/4	.236	Square	• EMC604300
								.015	• EMC604302
								.030	• EMC604304
								.060	EMC604306
								.090	EMC604308
								Ball	• EMC604310
TVNM-50375	3/8	3/8	1/2	4	5	2 1/8	.355	Square	• EMC604312
								.015	• EMC604314
								.030	• EMC604316
								.060	• EMC604318
								.090	• EMC604320
								.120	• EMC604322
TVNM-50500	1/2	1/2	5/8	5	5	2 3/4	.470	Square	• EMC604326
								.015	• EMC604328
								.030	• EMC604330
								.060	• EMC604332
								.090	• EMC604334
								.120	• EMC604336
TVNM-50625	5/8	5/8	3/4	5	5	3 1/8	0.593	Square	• EMC604344
								.030	• EMC604346
								.060	• EMC604348
								.090	• EMC604350
								.120	EMC604352
								.156	EMC604354
TVNM-50750	3/4	3/4	1 1/8	6	5	3 1/8	.715	Square	• EMC604362
								.030	• EMC604364
								.060	• EMC604366
								.090	• EMC604368
								.120	• EMC604370
								.156	EMC604372
TVNM-51000	1	1	1 1/4	6	5	3 1/8	.955	Square	EMC604380
								.030	EMC604382
								.060	• EMC604384
								.090	• EMC604386
								.120	• EMC604388
								.156	EMC604390
								.190	EMC604392
								.250	• EMC604394
								Ball	• EMC604396

• = In-Stock

Lead Times for non-stock EDP Numbers are 6 working days for uncoated tools and 8 working days for coated tools.



## TVNL-5 Long Length Necked

Description	Cutting DIA	SHK DIA	LOC	OAL	No of Flutes	Neck LGTH	Neck DIA	Corner Radius	AITiN
TVNL-50250	1/4	1/4	3/8	4	5	2 1/8	.236	Square	EMC604400
								.015	EMC604402
								.030	• EMC604404
								.060	EMC604406
								.090	EMC604408
								Ball	• EMC604410
TVNL-50375	3/8	3/8	1/2	4	5	2 5/8	.355	Square	EMC604412
								.015	EMC604414
								.030	• EMC604416
								.060	EMC604418
								.090	EMC604420
								.120	EMC604422
TVNL-50500	1/2	1/2	5/8	5	5	3 3/8	.470	Square	EMC604426
								.015	EMC604428
								.030	EMC604430
								.060	EMC604432
								.090	EMC604434
								.120	• EMC604436
								.156	EMC604438
								.190	EMC604440
								Ball	• EMC604442
								TVNL-50625	5/8
.030	EMC604446								
.060	EMC604448								
.090	EMC604450								
.120	EMC604452								
.156	EMC604454								
.190	EMC604456								
.250	EMC604458								
TVNL-50750	3/4	3/4	1 1/8	6	5	4 1/8	.715	Square	EMC604462
								.030	EMC604464
								.060	• EMC604466
								.090	EMC604468
								.120	• EMC604470
								.156	EMC604472
								.190	EMC604474
.250	• EMC604476								
TVNL-51000	1	1	1 1/4	7	5	4 1/8	.955	Square	EMC604480
								.030	EMC604482
								.060	EMC604484
								.090	EMC604486
								.120	• EMC604488
								.156	EMC604490
								.190	• EMC604492
								.250	• EMC604494
Ball	• EMC604496								

• = In-Stock

Lead Times for non-stock EDP Numbers are 6 working days for uncoated tools and 8 working days for coated tools.

# TV-7 SERIES TECHNICAL DATA FOR EXOTIC METAL FINISHERS

**NEW**

## Semi-Finish & Finish with Onsrud's 7 Flute High Performance End Mills

LMT Onsrud Exotic Metals 7 Flute End Mills are optimized for high speed machining with low radial engagement, producing accurate and superior surface finishes. The unique geometry and large core diameter prevents deflection on even the longest length tools.

LMT Onsrud's in house coating features High Heat Resistance which leads to increased wear resistance and tool life compared to industry standard AlTiN

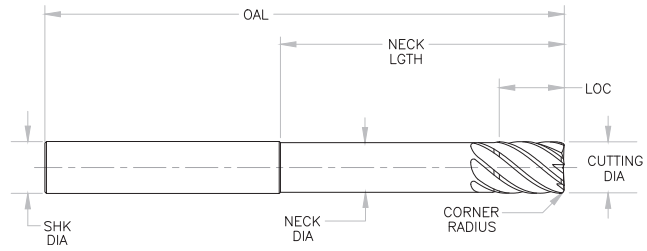

### CHIP LOAD PER TOOTH

Material/Grade	SFM	1/2	5/8	3/4	1
<b>Titanium</b>					
5553	180	.002	.0023	.0028	.003
6Al-4V	400				
Commercially Pure	90 -120				
<b>Cobalt Base</b>					
Haynes 21/26	40 - 80	.0014	.0017	.0021	.0029
NASA CO-W-RE	60 - 100				
Stellite					
<b>Iron Base</b>					
A-286, Discoly	50 - 80	.002	.0025	.003	.004
Incoly, Multimet	80 - 100				
Timken 16-25-6					
<b>Nickel Base</b>					
Hastalloy, Waspalloy	40 - 60	.002	.0025	.003	.004
Rene 41-95, Monel	45 - 100				
Inconel 625, 718					
<b>Austenitic Stainless</b>					
304, 310, 314	100 - 250	.0014	.0017	.0021	.0028
316L	100 - 350				
302, 304L					
<b>Precipitation Stainless</b>					
13-8PH, 15-5PH	90 - 250	.0014	.0017	.0021	.0028
17-4PH	100 - 350				
<b>Martensitic Stainless</b>					
420, 430F, 440	90 - 250	.0014	.0017	.0021	.0028
403, 410, 416	100 - 250				

Exotic Metals 7 Flute

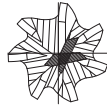

# TVS-7

## Standard Length

Description	Cutting DIA	SHK DIA	LOC	OAL	No of Flutes	Corner Radius	Coated EDP#
TVS-70500	1/2	1/2	5/8	2 1/2	7	Square	• EMC700051
						0.015	• EMC700053
						0.030	• EMC700055
						0.060	EMC700057
						0.090	EMC700059
						0.120	EMC700061
TVS-70625	5/8	5/8	3/4	3	7	Square	EMC700065
						0.030	• EMC700067
						0.060	EMC700069
						0.090	EMC700071
						0.120	EMC700073
						0.190	EMC700075
TVS-70750	3/4	3/4	1 1/8	3	7	Square	• EMC700079
						0.030	• EMC700081
						0.060	• EMC700083
						0.090	EMC700085
						0.120	• EMC700087
						0.190	EMC700089
TVS-71000	1	1	1 1/4	4	7	Square	• EMC700093
						0.030	• EMC700095
						0.060	• EMC700097
						0.090	EMC700099
						0.120	EMC700101
						0.190	EMC700103
						0.250	EMC700105

• = In-Stock

Lead Times for non-stock EDP Numbers are 6 working days for uncoated tools and 8 working days for coated tools.



# TVM-7

## Medium Length



Description	Cutting DIA	SHK DIA	LOC	OAL	No of Flutes	Corner Radius	Coated EDP#
TVM-70500	1/2	1/2	1 1/4	3	7	Square	• EMC700107
						0.015	• EMC700109
						0.030	• EMC700111
						0.060	EMC700113
						0.090	EMC700115
						0.120	EMC700117
TVM-70625	5/8	5/8	1 5/8	3 1/2	7	Square	EMC700121
						0.030	• EMC700123
						0.060	EMC700125
						0.090	EMC700127
						0.120	EMC700129
						0.190	EMC700131
TVM-70750	3/4	3/4	1 5/8	4	7	Square	• EMC700135
						0.030	• EMC700137
						0.060	• EMC700139
						0.090	EMC700141
						0.120	• EMC700143
						0.190	EMC700145
TVM-71000	1	1	2	5	7	Square	• EMC700149
						0.030	• EMC700151
						0.060	• EMC700153
						0.090	EMC700155
						0.120	• EMC700157
						0.190	EMC700159
						0.250	EMC700161

• = In-Stock

Lead Times for non-stock EDP Numbers are 6 working days for uncoated tools and 8 working days for coated tools.

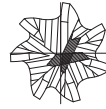

## TVL-7 Long Length

Description	Cutting DIA	SHK DIA	LOC	OAL	No of Flutes	Corner Radius	Coated EDP#
TVL-70500	1/2	1/2	2	4	7	Square	EMC700163
						0.015	• EMC700165
						0.030	• EMC700167
						0.060	EMC700169
						0.090	EMC700171
						0.120	EMC700173
TVL-70625	5/8	5/8	2 1/8	4	7	Square	EMC700177
						0.030	• EMC700179
						0.060	EMC700181
						0.090	EMC700183
						0.120	EMC700185
						0.190	EMC700187
TVL-70750	3/4	3/4	2 5/8	5	7	Square	EMC700191
						0.030	• EMC700193
						0.060	EMC700195
						0.090	EMC700197
						0.120	EMC700199
						0.190	EMC700201
						0.250	EMC700203
TVL-71000	1	1	3	6	7	Square	EMC700205
						0.030	EMC700207
						0.060	EMC700209
						0.090	EMC700211
						0.120	EMC700213
						0.190	EMC700215
						0.250	EMC700217

• = In-Stock

Lead Times for non-stock EDP Numbers are 6 working days for uncoated tools and 8 working days for coated tools.

# TVNS-7

## Standard Length Necked



Description	Cutting DIA	SHK DIA	LOC	OAL	No of Flutes	Neck LGTH	Neck DIA	Corner Radius	Coated EDP#
TVNS-70500	1/2	1/2	5/8	5	7	2 1/8	0.470	Square	• EMC700219
								0.015	• EMC700221
								0.030	• EMC700223
								0.060	EMC700225
								0.090	EMC700227
								0.120	EMC700229
TVNS-70625	5/8	5/8	3/4	5	7	2 3/8	0.593	Square	EMC700233
								0.030	EMC700235
								0.060	EMC700237
								0.090	EMC700239
								0.120	• EMC700241
								0.190	• EMC700243
TVNS-70750	3/4	3/4	1 1/8	5	7	2 5/8	0.715	Square	EMC700247
								0.030	• EMC700249
								0.060	EMC700251
								0.090	EMC700253
								0.120	• EMC700255
								0.190	• EMC700257
TVNS-71000	1	1	1 1/4	5	7	2 5/8	0.955	Square	EMC700261
								0.030	• EMC700263
								0.060	EMC700265
								0.090	EMC700267
								0.120	• EMC700269
								0.190	• EMC700271
	0.250	• EMC700273							

• = In-Stock

Lead Times for non-stock EDP Numbers are 6 working days for uncoated tools and 8 working days for coated tools.



## TVNM-7 Medium Length Necked

Description	Cutting DIA	SHK DIA	LOC	OAL	No of Flutes	Neck LGTH	Neck DIA	Corner Radius	Coated EDP#	
TVNM-70500	1/2	1/2	5/8	5	7	3 1/8	0.470	Square	• EMC700275	
								0.015	• EMC700277	
								0.030	• EMC700279	
								0.060	EMC700281	
								0.090	EMC700283	
								0.120	EMC700285	
TVNM-70625	5/8	5/8	3/4	5	7	3 1/8	0.593	Square	EMC700289	
								0.030	EMC700291	
								0.060	EMC700293	
								0.090	EMC700295	
								0.120	• EMC700297	
								0.190	• EMC700299	
TVNM-70750	3/4	3/4	1 1/8	5	7	3 1/8	0.715	Square	EMC700303	
								0.030	• EMC700305	
								0.060	• EMC700307	
								0.090	EMC700309	
								0.120	• EMC700311	
								0.190	• EMC700313	
TVNM-71000	1	1	1 1/4	5	7	3 1/8	0.955	Square	EMC700317	
								0.030	• EMC700319	
								0.060	EMC700321	
								0.090	EMC700323	
								0.120	• EMC700325	
								0.190	• EMC700327	
									0.250	• EMC700329

• = In-Stock

Lead Times for non-stock EDP Numbers are 6 working days for uncoated tools and 8 working days for coated tools.

# TVNL-7

## Long Length Necked



Description	Cutting DIA	SHK DIA	LOC	OAL	No of Flutes	Neck LGTH	Neck DIA	Corner Radius	Coated EDP#
TVNL-70500	1/2	1/2	5/8	6	7	4 1/8	0.470	Square	EMC700331
								0.015	EMC700333
								0.030	EMC700335
								0.060	EMC700337
								0.090	EMC700339
								0.120	EMC700341
TVNL-70625	5/8	5/8	3/4	6	7	4 1/8	0.593	Square	EMC700345
								0.030	EMC700347
								0.060	EMC700349
								0.090	EMC700351
								0.120	EMC700353
								0.190	EMC700355
TVNL-70750	3/4	3/4	1 1/8	6	7	4 1/8	0.715	Square	EMC700359
								0.030	EMC700361
								0.060	EMC700363
								0.090	EMC700365
								0.120	EMC700367
								0.190	EMC700369
TVNL-71000	1	1	1 1/4	7	7	4 1/8	0.955	Square	EMC700373
								0.030	EMC700375
								0.060	EMC700377
								0.090	EMC700379
								0.120	EMC700381
								0.190	EMC700383
								0.250	EMC700385

• = In-Stock

Lead Times for non-stock EDP Numbers are 6 working days for uncoated tools and 8 working days for coated tools.

# TF SERIES TECHNICAL DATA FOR EXOTIC METAL FINISHERS

## Onsrud's 6 Flute, 8 Flute & 10 Flute High-Performance End Mills

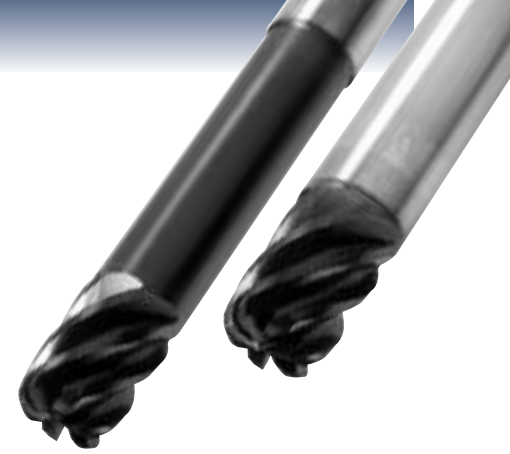

Finishers produce accurate parts with superior surface finishes that meet, or exceed, demanding aerospace specifications. Shallow flute design combined with a large core diameter prevents deflection on even the longest length tools. Eccentric relief creates a dampening effect to further reduce chatter on both thin wall parts and floors. Corner radii range from square to .250".

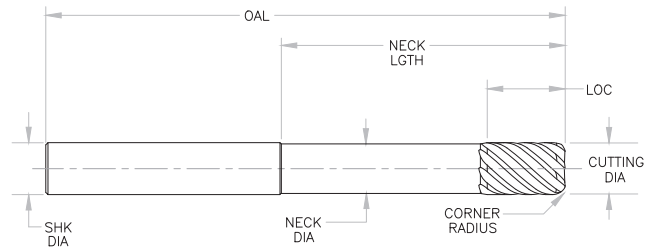

### CHIP LOAD PER TOOTH

Material/Grade	Finishing Series (Note: All Cutting Data Is For Profile Finishing)						
	SFM	1/4	3/8	1/2	5/8	3/4	1
<b>Titanium</b>							
5553	180	.0013	.0017	.002	.0023	.0028	.003
6Al-4V	400						
Commercially Pure	90 - 120						
<b>Cobalt Base</b>							
Haynes 21/26	40 - 80	.0011	.0013	.0014	.0017	.0021	.0029
NASA CO-W-RE	60 - 100						
Stellite							
<b>Iron Base</b>							
A-286, Discoly	50 - 80	.0015	.0017	.002	.0025	.003	.004
Incoly, Multimet	80 - 100						
Timken 16-25-6							
<b>Nickel Base</b>							
Hastalloy, Waspalloy	40 - 60	.0015	.0017	.002	.0025	.003	.004
Rene 41-95, Monel	45 - 100						
Inconel 625, 718							
<b>Austenitic Stainless</b>							
304, 310, 314	100 - 250	.001	.0013	.0014	.0017	.0021	.0028
316L	100 - 350						
302, 304L							
<b>Precipitation Stainless</b>							
13-8PH, 15-5PH	90 - 250	.001	.0013	.0014	.0017	.0021	.0028
17-4PH	100 - 350						
<b>Martensitic Stainless</b>							
420, 430F, 440	90 - 250	.001	.0013	.0014	.0017	.0021	.0028
403, 410, 416	100 - 250						

**Note:** Please call your LMT Onsrud Salesperson for programming tips!

# TFS

## Standard Length

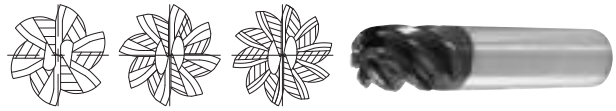

Description	Cutting DIA	SHK DIA	LOC	OAL	No of Flutes	Corner Radius	Coated EDP #
TFS-60250	1/4	1/4	3/8	2	6	Square	• EMC600900
						0.015	• EMC601104
						0.030	• EMC600916
						0.060	EMC600932
						0.090	EMC600948
TFS-60375	3/8	3/8	1/2	2	6	Square	• EMC600904
						0.015	• EMC601108
						0.030	• EMC600920
						0.060	• EMC600936
						0.090	• EMC600952
						0.120	• EMC600964
TFS-60500	1/2	1/2	5/8	2 1/2	6	Square	• EMC600908
						0.015	• EMC601112
						0.030	• EMC600924
						0.060	• EMC600940
						0.090	• EMC600956
						0.120	• EMC600968
						0.156	EMC600980
TFS-60625	5/8	5/8	3/4	3	6	Square	EMC600910
						0.030	• EMC600926
						0.060	EMC600942
						0.090	EMC600958
						0.120	EMC600970
						0.156	EMC600982
						0.190	EMC600990
TFS-80750	3/4	3/4	1 1/8	3	8	Square	EMC600912
						0.030	• EMC600928
						0.060	• EMC600944
						0.090	• EMC600960
						0.120	• EMC600972
						0.156	EMC600984
TFS-101000	1	1	1 1/4	3	10	Square	EMC600914
						0.030	• EMC600930
						0.060	• EMC600946
						0.090	• EMC600962
						0.120	• EMC600974
						0.156	EMC600986
						0.190	EMC600994
						0.250	EMC601000

• = In-Stock

Lead Times for non-stock EDP Numbers are 6 working days for uncoated tools and 8 working days for coated tools.

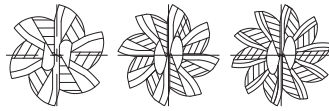

# TFM

## Medium Length

Description	Cutting DIA	SHK DIA	LOC	OAL	No of Flutes	Corner Radius	Coated EDP #
TFM-60250	1/4	1/4	3/4	2 1/2	6	Square	• EMC601002
						0.015	• EMC601120
						0.030	• EMC601018
						0.060	EMC601034
						0.090	EMC601050
TFM-60375	3/8	3/8	1 1/8	2 1/2	6	Square	• EMC601006
						0.015	• EMC601124
						0.030	• EMC601022
						0.060	• EMC601038
						0.090	• EMC601054
TFM-60500	1/2	1/2	1 1/4	3	6	Square	• EMC601010
						0.015	• EMC601128
						0.030	• EMC601026
						0.060	• EMC601042
						0.090	• EMC601058
TFM-60625	5/8	5/8	1 5/8	3 1/2	6	Square	EMC601012
						0.030	• EMC601028
						0.060	EMC601044
						0.090	EMC601060
						0.120	EMC601072
TFM-80750	3/4	3/4	1 5/8	4	8	Square	EMC601014
						0.030	• EMC601030
						0.060	• EMC601046
						0.090	• EMC601062
						0.120	• EMC601074
TFM-101000	1	1	2	4	10	Square	• EMC601016
						0.030	• EMC601032
						0.060	• EMC601048
						0.090	• EMC601064
						0.120	• EMC601076
						0.156	EMC601088
						0.190	EMC601096
						0.250	• EMC601102

• = In-Stock

Lead Times for non-stock EDP Numbers are 6 working days for uncoated tools and 8 working days for coated tools.



# TFNS

## Standard Length Necked

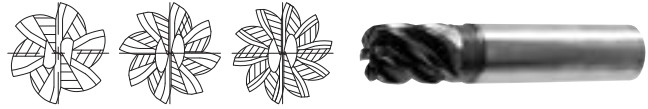

Description	Cutting DIA	SHK DIA	LOC	OAL	No of Flutes	Neck LGTHS	Neck DIA	Corner Radius	Coated EDP #
TFNS-60250	1/4	1/4	3/8	4	6	2 1/8	.236	Square	• EMC600002
								0.015	• EMC600104
								0.030	• EMC600018
								0.060	EMC600034
								0.090	EMC600050
TFNS-60375	3/8	3/8	1/2	4	6	2 1/4	.355	Square	• EMC600006
								0.015	• EMC600108
								0.030	• EMC600022
								0.060	• EMC600038
								0.090	• EMC600054
								0.120	• EMC600066
TFNS-60500	1/2	1/2	5/8	4	6	2 3/8	.470	Square	• EMC600010
								0.015	• EMC600112
								0.030	• EMC600026
								0.060	• EMC600042
								0.090	• EMC600058
								0.120	• EMC600070
TFNS-60625	5/8	5/8	3/4	4	6	2 3/8	0.593	Square	EMC600012
								0.030	• EMC600028
								0.060	EMC600044
								0.090	EMC600060
								0.120	• EMC600072
								0.156	EMC600084
TFNS-80750	3/4	3/4	1 1/8	4	8	2 1/2	.715	Square	EMC600014
								0.030	• EMC600030
								0.060	• EMC600046
								0.090	• EMC600062
								0.120	• EMC600074
								0.156	EMC600086
TFNS-101000	1	1	1 1/4	5	10	2 1/2	.955	Square	EMC600016
								0.030	• EMC600032
								0.060	• EMC600048
								0.090	• EMC600064
								0.120	• EMC600076
								0.156	EMC600088
	0.190	EMC600096							
	0.250	• EMC600102							

• = In-Stock

Lead Times for non-stock EDP Numbers are 6 working days for uncoated tools and 8 working days for coated tools.

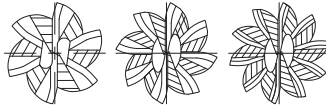

# TFNM

## Medium Length Necked

Description	Cutting DIA	SHK DIA	LOC	OAL	No of Flutes	Neck LGTHS	Neck DIA	Corner Radius	Coated EDP #
TFNM-60250	1/4	1/4	3/8	4	6	2 1/2	.236	Square	EMC600302
								0.015	• EMC600402
								0.030	• EMC600318
								0.060	EMC600334
								0.090	EMC600350
TFNM-60375	3/8	3/8	1/2	4	6	2 5/8	.355	Square	EMC600306
								0.015	• EMC600406
								0.030	• EMC600322
								0.060	EMC600338
								0.090	• EMC600354
TFNM-60500	1/2	1/2	5/8	6	6	3 1/8	.470	Square	EMC600310
								0.015	• EMC600410
								0.030	• EMC600326
								0.060	EMC600342
								0.090	• EMC600358
TFNM-60625	5/8	5/8	3/4	6	6	3 1/8	0.593	Square	EMC600312
								0.030	• EMC600328
								0.060	EMC600344
								0.090	EMC600360
								0.120	• EMC600372
TFNM-80750	3/4	3/4	1 1/8	6	8	3 1/8	.715	Square	EMC600314
								0.030	• EMC600330
								0.060	• EMC600346
								0.090	EMC600362
								0.120	• EMC600374
TFNM-101000	1	1	1 1/4	6	10	3 1/8	.955	Square	EMC600316
								0.030	• EMC600332
								0.060	EMC600348
								0.090	EMC600364
								0.120	• EMC600376
								0.156	EMC600388
								0.190	• EMC600396
								0.250	• EMC600400

• = In-Stock

Lead Times for non-stock EDP Numbers are 6 working days for uncoated tools and 8 working days for coated tools.

# TFNL

## Long Length Necked



Description	Cutting DIA	SHK DIA	LOC	OAL	No of Flutes	Neck LGTHS	Neck DIA	Corner Radius	Coated EDP #
TFNL-60250	1/4	1/4	3/8	4	6	3 1/8	.236	Square	EMC600600
								0.015	EMC600700
								0.030	• EMC600616
								0.060	EMC600632
								0.090	EMC600648
TFNL-60375	3/8	3/8	1/2	6	6	3 1/4	.355	Square	EMC600604
								0.015	EMC600704
								0.030	• EMC600620
								0.060	EMC600636
								0.090	• EMC600652
TFNL-60500	1/2	1/2	5/8	6	6	4 1/8	.470	Square	EMC600608
								0.015	EMC600708
								0.030	• EMC600624
								0.060	EMC600640
								0.090	• EMC600656
TFNL-60625	5/8	5/8	3/4	6	6	4 1/8	.593	Square	EMC600610
								0.030	• EMC600626
								0.060	EMC600642
								0.090	EMC600658
								0.120	• EMC600670
TFNL-80750	3/4	3/4	1 1/8	6	8	4 1/8	.715	Square	EMC600612
								0.030	• EMC600628
								0.060	• EMC600644
								0.090	EMC600660
								0.120	• EMC600672
TFNL-101000	1	1	1 1/4	7	10	4 1/8	.955	Square	EMC600614
								0.030	• EMC600630
								0.060	EMC600646
								0.090	EMC600662
								0.120	• EMC600674
								0.156	EMC600686
								0.190	• EMC600694
								0.250	• EMC600698

• = In-Stock

Lead Times for non-stock EDP Numbers are 6 working days for uncoated tools and 8 working days for coated tools.

# Routing Tools for Special Applications

LMT Onsrud is a leading supplier of small diameter, high rpm tooling for CNC routing and milling of aluminum sheet, stacks and extrusions. Our unique single flute tool design features increased clearance resulting in maximum chip flow and maximum productivity at high rpm and feed rates.

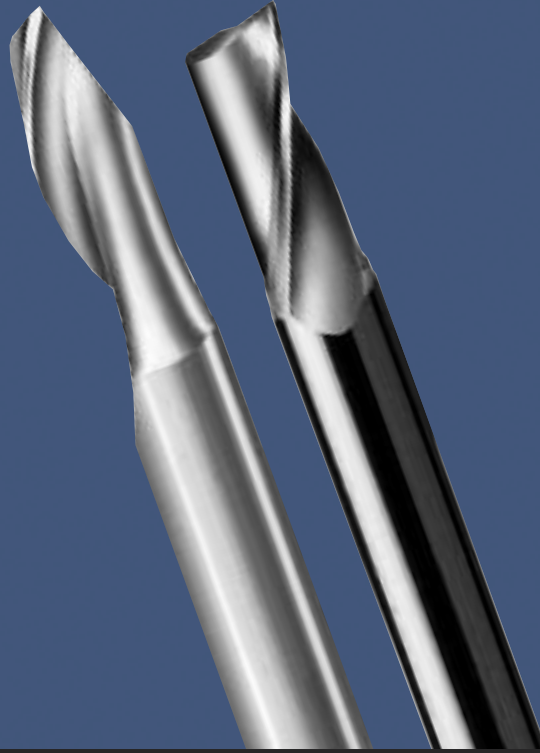

## SPECIALTY TOOL CHIPLOADS

**DEPTH OF CUT:** 1 x D Use recommended chip load  
2 x D Reduce chip load by 25%  
3 x D Reduce chip load by 50%

### CHIP LOAD PER TOOTH

		Cutting Edge Diameter															
Series	Cut	1/16	3/32	1/8	5/32	3/16	7/32	1/4	5/16	3/8	7/16	1/2	9/16	5/8	3/4	7/8	1
40-000*	1 x D			.005 - .007		.005 - .007	.005 - .007	.006 - .008	.006 - .008	.007 - .009		.008 - .010					
49-000	1 x D							.004 - .006	.004 - .006	.006 - .008							
62-600	1 x D	.002 - .004		.002 - .004		.003 - .006		.003 - .006	.003 - .006	.004 - .008		.008 - .010					
62-900	1 x D	.002 - .004		.002 - .004		.003 - .006		.003 - .006	.003 - .006	.004 - .008		.008 - .010					
63-600	1 x D	.002 - .004		.002 - .004		.003 - .006		.003 - .006	.003 - .006	.004 - .008		.008 - .010					
80-000	1 x D	.002 - .004		.002 - .004		.002 - .004											

**NOTE:** When cutting soft aluminum a squirt of cutting fluid every now and then will help to eliminate chip rewelding and improve surface finish

**FORMULAS:** Chip Load = Feed Rate / (RPM x # of cutting edges)  
Feed Rate (IPM) = RPM x # of cutting edges x chip load  
Speed (RPM) = Feed Rate / (# of cutting edges x chip load)

**DEFINITIONS:** IPM = Inches Per Minute  
IPR = Inches Per Revolution

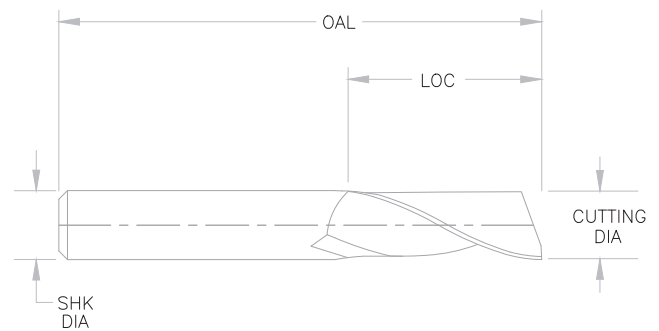

## 40-000



### 1 Flute - High Speed Steel Upcut Spiral

Designed for routing applications where speed and chip removal are primary considerations. They are also recommended when grooving, slotting or blind routing.

**Usage** Sheet and stacked aluminum

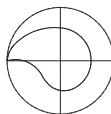

Part Number	Cutting DIA	LOC	SHK DIA	OAL
40-001	1/8	3/8	1/4	2 5/8
40-003	3/16	5/8	1/4	2 7/8
40-005	1/4	5/8	1/4	2 3/4
40-009	1/4	3/4	1/2	3 1/4
40-021	5/16	3/4	1/2	3 1/4
40-023	5/16	1	1/2	3 1/2
40-025	21/64	3/4	1/2	3 1/4
40-033	3/8	1	1/2	3 1/2

HELIX ANGLE  $\approx 19^\circ - 32^\circ$  Shear

These tools are designed and toleranced for air routers with guide bushings.

## 40-000



### 1 Flute - High Speed Steel Downcut Spiral

Designed for through cut routing operations where speed is the primary concern and fixturing is such that both chips and material are better off forced down.

**Usage** Sheet aluminum

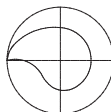

Part Number	Cutting DIA	LOC	SHK DIA	OAL
40-008	1/4	3/4	1/4	2 3/4
40-012	1/4	1	1/4	3

HELIX ANGLE  $\approx 19^\circ - 32^\circ$  Shear

These tools are designed and toleranced for air routers with guide bushings.

## 49-000



### 2 Flute - High Speed Steel Downcut

These double flute downcuts with a drill type point were developed initially as "Aircraft Throwaway" tools. They have many uses in trimming and routing primarily with hand held routers.

**Usage** Aluminum

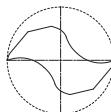

Part Number	Cutting DIA	LOC	SHK DIA	OAL
49-005	1/4	9/16	1/4	2 1/2
49-001	1/4	9/16	1/4	2 3/4
49-007	1/4	9/16	1/4	3 1/4
49-003	3/8	3/4	3/8	2 1/2

THESE TOOLS ARE DESIGNED AND TOLERANCED FOR AIR ROUTERS WITH GUIDE BUSHINGS, + .000 - .006

HELIX ANGLE  $\approx 24^\circ$

## 1 Flute - Solid Carbide Downcut Spiral O Flute

High speed cutters for machining aluminum sheet material. These tools are optimized for use on high-speed CNC mills, high speed machining centers and CNC routers.

**Usage** Aluminum sheet or extrusions

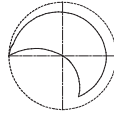

Part Number	Cutting DIA	LOC	SHK DIA	OAL
62-602	1/16	1/4	1/8	1 1/2
62-604	1/8	1/4	1/8	1 1/2
62-606	1/8	1/4	1/4	2
62-610	1/8	1/2	1/4	2
62-614	3/16	3/8	1/4	2
62-620	1/4	3/8	1/4	2
62-622	1/4	3/4	1/4	2 1/2
62-624	1/4	1 1/4	1/4	3
62-630	5/16	3/4	1/2	3
62-625	3/8	3/4	3/8	3
62-631	1/2	1 1/8	1/2	3 1/2

HELIX ANGLE  $\approx 22^\circ$



## 1 Flute - Solid Carbide Upcut for Soft Aluminum

These tools are specially designed to cut soft grades of aluminum and create a good edge finish. The improved cutting geometry properly forms and evacuates the chips preventing chip rewelding.

**Usage** Aluminum sheet

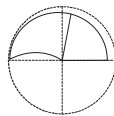

Part Number	Cutting DIA	LOC	SHK DIA	OAL	COATING
63-420	3/16	1/4	1/4	2	ZRN
63-430	1/4	1/4	1/4	2	ZRN
63-450	5mm	6mm	6mm	64mm	ZRN
63-460	6mm	6mm	6mm	64mm	ZRN

### Cutting Parameters

Part Number	RPM	Feed Rate
63-420	10,000	80 IPM
63-430	13,250	100 IPM
63-450	10,000	80 IPM
63-460	13,250	100 IPM



**NEW**

## 63-600



### 1 Flute - Solid Carbide Upcut Spiral O Flute

High speed cutters for machining aluminum sheet and block material. These tools are optimized for use on high-speed CNC mills, high speed machining centers and CNC routers.

**Usage** Aluminum plate, single/multi sheet aluminum and extrusions

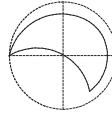

Part Number	Cutting DIA	LOC	SHK DIA	OAL
63-602	1/16	1/4	1/8	1 1/2
63-603	3/32	1/4	1/8	2
63-604	1/8	1/4	1/8	1 1/2
63-606	1/8	1/4	1/4	2
63-610	1/8	1/2	1/4	2
63-611	5/32	5/16	3/16	2
63-612	3/16	3/8	3/16	1 1/2
63-614	3/16	3/8	1/4	2
63-618	3/16	5/8	1/4	2
63-620	1/4	3/8	1/4	2
63-622	1/4	3/4	1/4	2 1/2
63-624	1/4	1 1/4	1/4	3
63-629	5/16	9/16	5/16	2 1/2
63-630	5/16	3/4	1/2	3
63-634	21/64	3/4	1/2	3
63-625	3/8	3/4	3/8	3
63-626	3/8	1 1/8	3/8	3
63-627	3/8	1 3/8	3/8	3 1/2
63-631	1/2	1 1/8	1/2	3 1/2
63-632	1/2	1 3/8	1/2	3 1/2

HELIX ANGLE ≈ 22°

## 63-900



### 1 Flute - Solid Carbide Upcut Spiral O Flute

High speed cutters for machining aluminum sheet and block material. These tools are optimized for use on high-speed CNC mills, high speed machining centers and CNC routers.

**Usage** Aluminum plate, single/multi sheet aluminum and extrusions

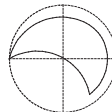

Part Number	Cutting DIA	LOC	SHK DIA	OAL
63-904	2mm	6mm	6mm	64mm
63-908	2.5mm	6mm	6mm	64mm
63-912	3mm	8mm	6mm	64mm
63-916	3mm	12mm	6mm	64mm
63-918	4mm	8mm	4mm	64mm
63-924	4mm	20mm	6mm	64mm
63-930	5mm	16mm	6mm	64mm
63-934	6mm	8mm	6mm	64mm
63-938	6mm	20mm	6mm	64mm
63-944	8mm	25mm	8mm	64mm
63-946	8mm	38mm	8mm	76mm
63-948	10mm	30mm	10mm	76mm

HELIX ANGLE ≈ 22°

# LMT Onsrud LP - END MILL REQUEST FORM

1081 S. Northpoint Blvd. • Waukegan, Illinois 60085 • Phone (847) 362-1560 • Fax (800) 557-6720 • www.onsrud.com

\*Starred Items = Required information

\*Distributor's Reference Number \_\_\_\_\_

\*Distributor Name \_\_\_\_\_

\*Distributor Address \_\_\_\_\_

\*Contact \_\_\_\_\_

\*Telephone \_\_\_\_\_ \*Fax \_\_\_\_\_

End user name \_\_\_\_\_

Customer Quote number \_\_\_\_\_

End user address \_\_\_\_\_

Contact \_\_\_\_\_

\*Telephone \_\_\_\_\_ \*Fax \_\_\_\_\_

\*Material being machined \_\_\_\_\_ Hardness \_\_\_\_\_

Machine type (Check all that apply):  Vertical  Horizontal  Multi Spindle  Geared Head  Belt Drive  Other

Machine Make and Model \_\_\_\_\_

H.P.= \_\_\_\_\_ Rigidity of Set-Up \_\_\_\_\_

Max. Spindle Speed \_\_\_\_\_ Spindle Taper \_\_\_\_\_

Coolant Type \_\_\_\_\_ Through the Spindle Coolant  Yes  No

\*Style of Milling  Slotting  Profiling  Pocketing  Multi Axis

Approval drawings  Not necessary  Required

\*Tool Material (Specify if other than carbide) \_\_\_\_\_

Tool Modification (Tool to be modified) \_\_\_\_\_

Corner Radius  Chamfer  Weldon Flat  Whistle Notch

Quote Quantities \_\_\_\_\_

Yearly Quantities \_\_\_\_\_

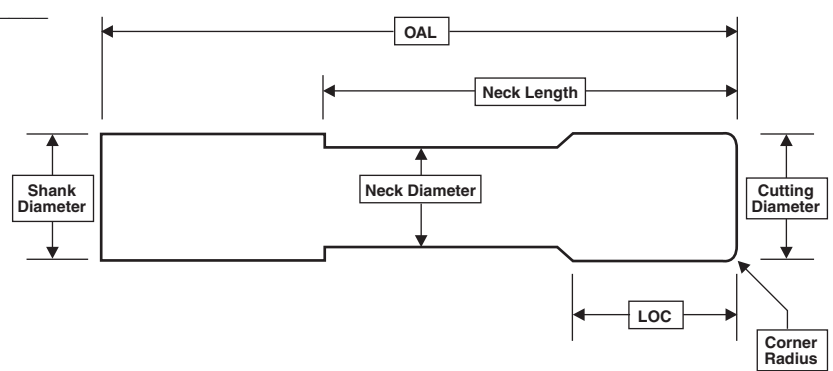

Cutting Diameter \_\_\_\_\_

Shank Diameter \_\_\_\_\_

Length of Cut (LOC) \_\_\_\_\_

Neck Diameter \_\_\_\_\_

Neck Length \_\_\_\_\_

Overall Length (OAL) \_\_\_\_\_

Number of Flutes \_\_\_\_\_

Corner Radius \_\_\_\_\_

Coating \_\_\_\_\_

Coolant Through \_\_\_\_\_

Cylindrical Margin \_\_\_\_\_

Notes: \_\_\_\_\_  
 \_\_\_\_\_  
 \_\_\_\_\_









## LMT Onsrud Terms & Conditions

**Shipping** - F.O.B. Waukegan, IL. All shipments ground unless otherwise specified.

**Claims** – Any claims for shortage, damage or loss must be made within 30 days of invoice date. United Parcel Service is a preferred method of shipment because of reliability and ease of tracing problem shipments.

**Guarantee** - Our products are guaranteed against defects in material and quality of manufacture when used in the proper manner. If tools are returned and found to be defective, we will repair or replace the tools. Continued tool breakage caused by improper tool usage without the knowledge of LMT Onsrud's technical staff is not a condition for return and replacement of such tools.

**Errors** - LMT Onsrud, LP cannot be held responsible for incorrect parts made with our products due to mislabeling or defect.

**Return Goods Policy** – No merchandise can be returned without prior authorization. Credit will not be issued for merchandise returned without a return authorization number. Product must be a current revision catalog item in new and saleable condition. All returns subject to a 15% restocking fee or offsetting order of equal value.

**Specials** - LMT Onsrud, LP has the right to over or under ship by 10% all specials. Special orders less than 10 pieces are subject to +/- 1 piece. Specials and modified tools are not returnable for credit. Specials cancelled will be assessed an in-process charge based on the status of the order and expenses incurred at the time of cancellation. If a special tool has been completed, the tool will be shipped and the price quoted will be billed.

**Safety Precautions** – Cutting tools should only be used to perform operations that are compatible with the original tool design. Safety glasses and other appropriate safety equipment should be worn by all people in the vicinity of tool use.

**Prices & Terms** - All prices and terms are subject to change without notice. All orders are subject to acceptance at LMT Onsrud.



**LMT Onsrud LP**  
1081 S. Northpoint Blvd.  
Waukegan, IL 60085 USA  
Toll Free: + 1 800 234 1560  
Direct: + 1 847 362 1560  
[www.onsrud.com](http://www.onsrud.com)

**ISO 9001 Certified**



**LMT Tool Systems GmbH**  
Heidenheimer Straße 84  
73447 Oberkochen  
Fon +49 73 64 95 79-0  
Fax +49 73 64 95 79-80 00  
[lm.de@lmt-tools.com](mailto:lm.de@lmt-tools.com)  
[www.lmt-tools.com](http://www.lmt-tools.com)

Distributed By:

Printed in USA/Catalog OCMR-12

**LMT BELIN S.A.S.**  
01590 Lavancia  
Frankreich  
Telefon +33 474 758989  
Telefax +33 474 758990  
[info@lmt-belin.com](mailto:info@lmt-belin.com)  
[www.lmt-belin.com](http://www.lmt-belin.com)

**LMT FETTE Werkzeugtechnik GmbH & Co. KG**  
Grabauer Straße 24  
21493 Schwarzenbek  
Deutschland  
Telefon +49 4151 12-0  
Telefax +49 4151 3797  
[info@lmt-fette.com](mailto:info@lmt-fette.com)  
[www.lmt-fette.com](http://www.lmt-fette.com)

**LMT KIENINGER GmbH**  
Vogesenstraße 23  
77933 Lahr  
Deutschland  
Telefon +49 7821 943-0  
Telefax +49 7821 943213  
[info@lmt-kienger.com](mailto:info@lmt-kienger.com)  
[www.lmt-keinnger.com](http://www.lmt-keinnger.com)

**LMT ONSRUD LP**  
1081 S. Northpoint Blvd.  
Waukegan, Illinois 60085  
USA  
Phone +1 847 362 1560  
Fax +1 800 557 6720  
[info@onsrud.com](mailto:info@onsrud.com)  
[www.onsrud.com](http://www.onsrud.com)

in alliance **BILZ Werkzeugfabrik GmbH & Co. KG**  
Vogelsangstraße 8  
73760 Ostfildern  
Deutschland  
Telefon +49 711 348010  
Telefax +49 711 3481256  
[info@bilz.com](mailto:info@bilz.com)  
[www.bilz.com](http://www.bilz.com)

**BOEHLERIT GmbH & Co. KG**  
Werk-VI-Straße  
8605 Kapfenberg  
Osterreich  
Telefon +43 3862 300-0  
Telefax +43 3862 300793  
[info@boehlert.com](mailto:info@boehlert.com)  
[www.boehlert.com](http://www.boehlert.com)

LMT Technology Group  
**BELIN  
FETTE  
KIENINGER  
ONSRUD**  
in alliance  
**BILZ  
BOEHLERIT**