

NMTB and R8 Morse Taper Holders

- Balanced to 12,000RPM
- Coolant-thru capable



TIR: minimal



Speed: up to 12,000 rpm



Set-up: quick and easy



Coolant-thru: available



Drilling
★★★★☆



Reaming
★★★★☆

Please note that the maximum RPM listed in our catalog may vary depending on the toolholder shank, weight, balanceability and the G rating.

NMTB 30/40/50

Part Number	Taper	Size	L	D	D1
N3004-0001-1.00	NMTB30	MT#1	1.00"	0.48"	1.00"
N3004-0002-2.13	NMTB30	MT#2	2.13"	0.70"	1.25"
N3004-0003-2.81	NMTB30	MT#3	2.81"	0.94"	1.57"
N4004-0001-0.94	NMTB40	MT#1	0.94"	0.48"	1.00"
N4004-0002-1.75	NMTB40	MT#2	1.75"	0.70"	1.25"
N4004-0003-2.25	NMTB40	MT#3	2.25"	0.94"	1.57"
N4004-0004-3.00	NMTB40	MT#4	3.00"	1.23"	1.97"
N5004-0002-1.88	NMTB50	MT#2	1.88"	0.70"	1.25"
N5004-0003-2.38	NMTB50	MT#3	2.38"	0.94"	1.57"
N5004-0004-3.25	NMTB50	MT#4	3.25"	1.23"	1.97"
N5004-0005-4.63	NMTB50	MT#5	4.63"	1.75"	2.75"

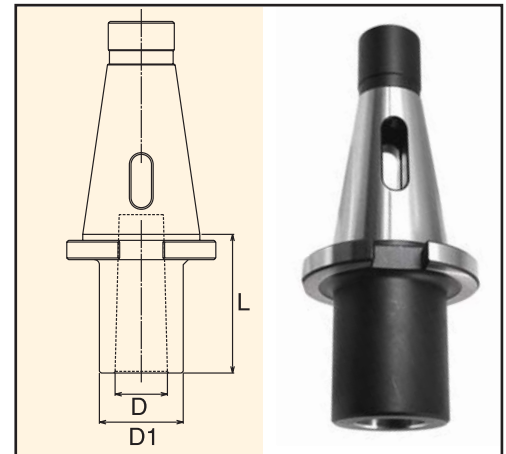

NMTB shanks are suitable for use with Erickson QC spindles.

R8

Part Number	Taper	Size	L	D	D1
840-001-0.44	R8	MT#1	0.44"	0.48"	1.00"
840-002-0.44	R8	MT#2	0.44"	0.70"	1.25"
840-003-2.56	R8	MT#3	2.56"	0.94"	1.57"

