

NMTB and R8 Jacobs Taper Holders

NMTB30/40/50

Part Number	Taper	JT Size	L	D
N3003-0001-0.63	NMTB30	JT#1	0.63"	.385"
N3003-0002-0.59	NMTB30	JT#2	0.59"	.560"
N3003-0003-0.55	NMTB30	JT#3	0.55"	.812"
N3003-0006-0.59	NMTB30	JT#6	0.59"	.677"
N3003-0033-0.59	NMTB30	JT#33	0.59"	.625"
N4003-0001-0.69	NMTB40	JT#1	0.69"	.385"
N4003-0002-0.65	NMTB40	JT#2	0.65"	.560"
N4003-0003-0.61	NMTB40	JT#3	0.61"	.812"
N4003-0006-0.65	NMTB40	JT#6	0.65"	.677"
N4003-0033-0.65	NMTB40	JT#33	0.65"	.625"
N5003-0002-1.34	NMTB50	JT#2	1.34"	.560"
N5003-0003-1.30	NMTB50	JT#3	1.30"	.812"
N5003-0004-1.22	NMTB50	JT#4	1.22"	1.13"
N5003-0006-1.34	NMTB50	JT#6	1.34"	.677"
N5003-0033-1.34	NMTB50	JT#33	1.34"	.625"

NMTB shanks are suitable for use with Erickson QC spindles.

R8

Part Number	Taper	JT Size	L	D
870-001-0.13	R8	JT#1	0.13"	.385"
870-002-0.13	R8	JT#2	0.13"	.560"
870-003-0.13	R8	JT#3	0.13"	.812"
870-006-0.13	R8	JT#6	0.13"	.677"
870-033-0.13	R8	JT#33	0.13"	.625"

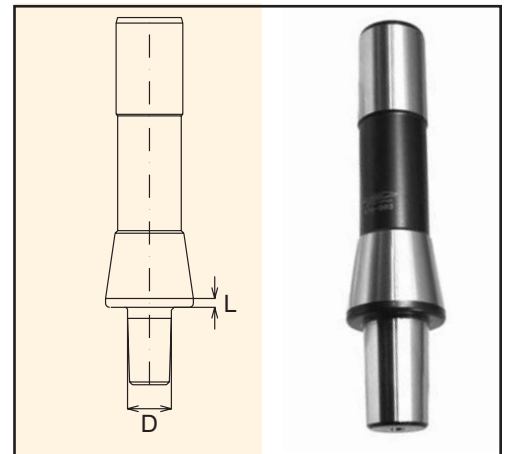
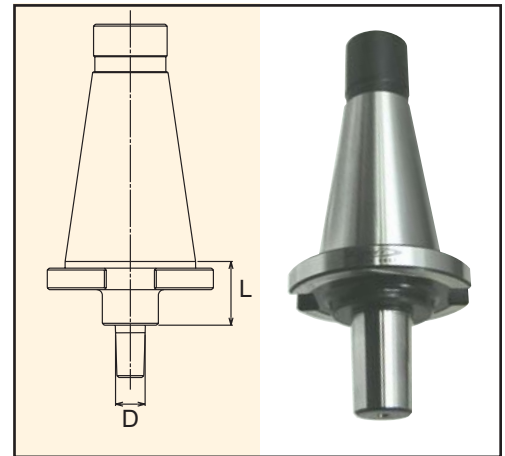

Accessories:



Jacobs Brand Drill Chuck
Page 92



Replacement Key
Page 92