





NMTB and R8 Stub Mill Holders

- Taper ground to AT3 or better to ensure 80% taper contact
- 1/8", 1/4", 3/8" and 1/2" ground arbor spacers included with every holder
- h6 precision ground pilot for concentric and repeatable mounting diameter

-  **TIR:** < .0002 run out along pilot
-  **Speed:** up to 15,000 rpm
-  **Set-up:** quick and easy
-  **Coolant-thru:** opt. not available

Please note that the maximum RPM listed in our catalog may vary depending on the toolholder shank, weight, balanceability and the G rating.

NMTB30/40/50

Part Number	Taper	d	L	D	L1	Key Size
N3002-0750-4.97	NMTB30	3/4"	4.97"	1.25"	3.00"	1/8"
N3002-1000-5.18	NMTB30	1"	5.18"	1.50"	3.00"	1/4"
N3002-1250-5.28	NMTB30	1-1/4"	5.28"	1.75"	3.00"	5/16"
N4002-0750-5.00	NMTB40	3/4"	5.00"	1.25"	3.00"	1/8"
N4002-1000-5.18	NMTB40	1"	5.18"	1.50"	3.00"	1/4"
N4002-1250-5.28	NMTB40	1-1/4"	5.28"	1.75"	3.00"	5/16"
N4002-1500-5.62	NMTB40	1-1/2"	5.62"	2.12"	3.00"	3/8"
N5002-1000-6.18	NMTB50	1"	6.18"	1.50"	4.00"	1/4"
N5002-1250-6.28	NMTB50	1-1/4"	6.28"	1.75"	4.00"	5/16"
N5002-1500-6.60	NMTB50	1-1/2"	6.60"	2.12"	4.00"	3/8"

Note: 1/8", 1/4", 3/8" and 1/2" arbor spacers and securing nut included as standard with all listed toolholders. NMTB shanks are suitable for use with Erickson QC spindles.

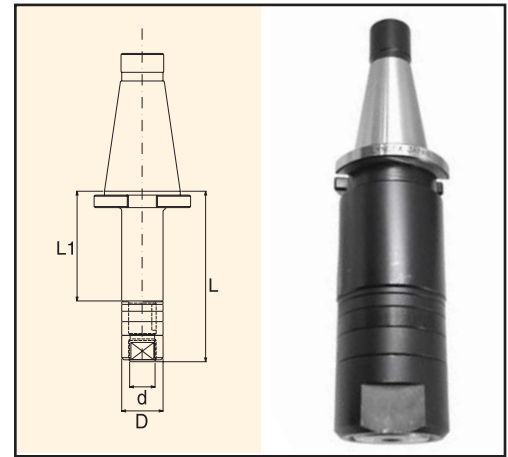

R8

Part Number	Taper	d	L	D	L1	Key Size
880-064-2.76	R8	1.00"	2.76"	1.50"	0.48"	1/4"
880-080-2.82	R8	1.25"	2.82"	1.75"	0.50"	5/16"

Note: 1/8", 1/4", 3/8" and 1/2" arbor spacers and securing nut included as standard with all listed toolholders.

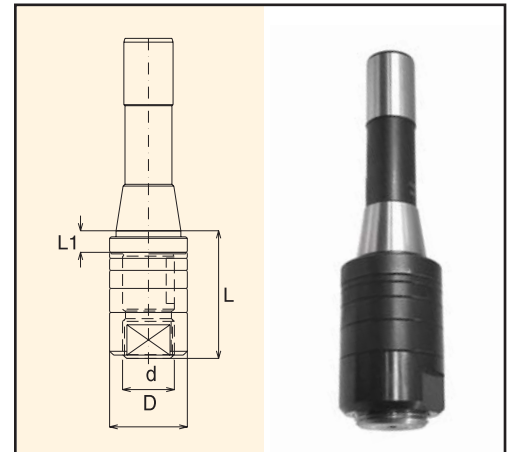

Accessories:



Replacement Nut
Page 123



Replacement Spacer
Page 123

End Mill Holders
ERTG/DA Collet Chucks
Shell Mill Holders
Drill Chucks
Tap Holders
Stub, Boring, Blank