

CAT and BT Stub Mill Holders

- Taper ground to AT3 or better to ensure 80% taper contact
- 1/8", 1/4", 3/8" and 1/2" ground arbor spacers included with every holder
- h6 precision ground pilot for concentric and repeatable mounting diameter

Please note that the maximum RPM listed in our catalog may vary depending on the toolholder shank, weight, balanceability and the G rating.



TIR: < .0002 run out along pilot



Speed: up to 15,000 rpm



Set-up: quick and easy



Coolant-thru: opt. not available

CAT40/50

Part Number	Taper	d	L	D	L1	Key Size
C4002-1000-6.17	CT40	1"	6.17"	1.50"	4.00"	1/4"
C4002-1250-6.29	CT40	1-1/4"	6.29"	1.75"	4.00"	5/16"
C4002-1500-6.60	CT40	1-1/2"	6.60"	2.12"	4.00"	3/8"
C5002-1000-6.17	CT50	1"	6.17"	1.50"	4.00"	1/4"
C5002-1250-6.28	CT50	1-1/4"	6.28"	1.75"	4.00"	5/16"
C5002-1500-6.60	CT50	1-1/2"	6.60"	2.12"	4.00"	3/8"

Note: 1/8", 1/4", 3/8" and 1/2" arbor spacers and securing nut included as standard with all listed toolholders.

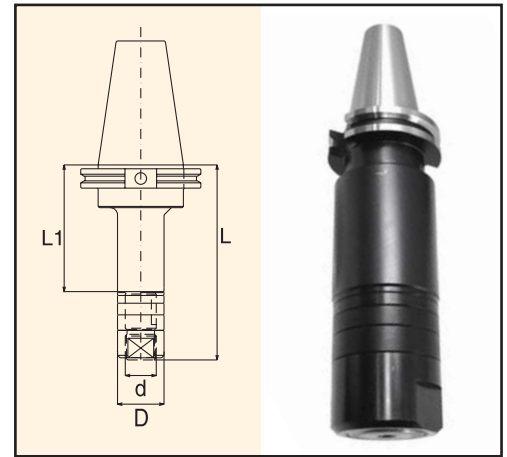

BT30/40/50

Part Number	Taper	d	L	D	L1	Key Size
B3002-0750-4.97	BT30	3/4"	4.97"	1.25"	3.00"	1/8"
B3002-1000-5.17	BT30	1"	5.17"	1.50"	3.00"	1/4"
B4002-1000-5.18	BT40	1"	5.18"	1.50"	3.00"	1/4"
B4002-1250-5.32	BT40	1-1/4"	5.32"	1.75"	3.00"	5/16"
B4002-1500-5.60	BT40	1-1/2"	5.60"	2.12"	3.00"	3/8"
B5002-1000-6.17	BT50	1"	6.17"	1.50"	4.00"	1/4"
B5002-1250-6.28	BT50	1-1/4"	6.28"	1.75"	4.00"	5/16"
B5002-1500-6.60	BT50	1-1/2"	6.60"	2.12"	4.00"	3/8"

Note: 1/8", 1/4", 3/8" and 1/2" arbor spacers and securing nut included as standard with all listed toolholders.

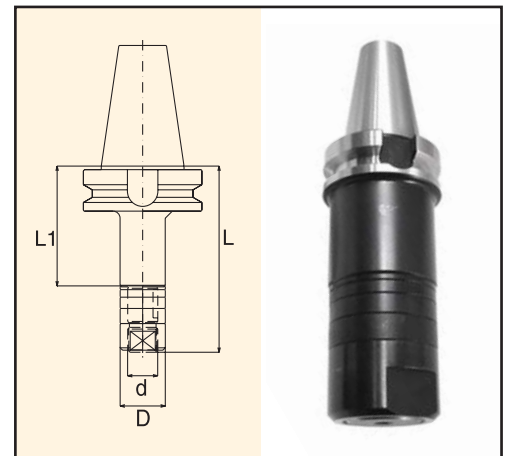

Accessories:



Replacement Nut
Page 123



Replacement Spacer
Page 123