

# BT End Mill Holders

- End mill inner bore T.I.R.  $\leq 0.0002$
- Through-spindle coolant capability
- AT3 or better taper
- Available in high-speed balanceable versions



**TIR:** < .0002 run out in ID bore



**Milling**  
★★★★☆



**Speed:** up to 20,000 rpm



**Tapping**  
★★★★☆



**Set-up:** quick and easy



**Coolant-thru:** jet slots (optional)

Please note that the maximum RPM listed in our catalog may vary depending on the toolholder shank, weight, balanceability and the G rating.

## BT30 - Inch

Part Number	Style	d	L	L1	D	Set Screw Part Number
B3006-0125-2.36	Standard	1/8"	2.36"	0.63"	0.75"	S6-32X1/4
B3006-0187-2.36	Standard	3/16"	2.36"	0.87"	0.75"	S8-32X1/4
B3006-0250-2.36	Standard	1/4"	2.36"	1.10"	0.79"	S1/4-28X1/4
B3006-0312-2.36	Standard	5/16"	2.36"	1.26"	0.87"	S5/16-24X1/4
B3006-0375-2.36	Standard	3/8"	2.36"	1.26"	1.00"	S3/8-24X5/16
B3006-0437-2.36	Standard	7/16"	2.36"	1.50"	1.38"	S7/16-20X3/8
B3006-0500-2.36	Standard	1/2"	2.36"	1.50"	1.38"	S7/16-20X3/8
B3006-0625-2.50	Standard	5/8"	2.50"	1.61"	1.65"	S9/16-18X1/2
B3006-0750-3.00	Standard	3/4"	3.00"	1.77"	1.88"	S5/8-18X1/2
B3006-0875-3.54	Standard	7/8"	3.54"	2.09"	2.00"	S5/8-18X1/2 (2)
B3006-1000-3.54	Standard	1"	3.54"	2.36"	2.36"	S3/4-16X11/16 (2)

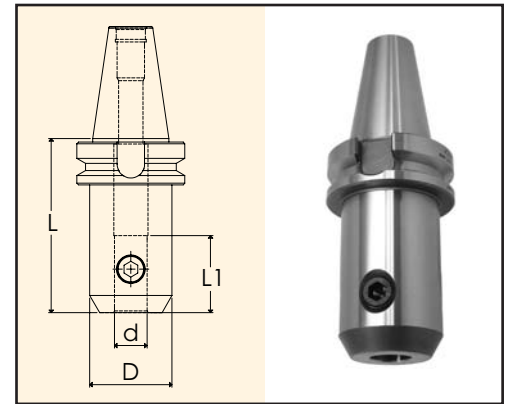

Set Screws are included. Back-up screws not included.

## BT30 - Metric

Part Number	Style	d	L	L1	D	Set Screw Part Number
B3006-6-2.50	Standard	6mm	2.50"	1.10"	0.79"	S1/4-28X1/4
B3006-8-2.50	Standard	8mm	2.50"	1.26"	0.87"	S5/16-24X1/4
B3006-10-2.50	Standard	10mm	2.50"	1.26"	1.00"	S3/8-24X5/16
B3006-12-2.50	Standard	12mm	2.50"	1.50"	1.38"	S7/16-20X3/8
B3006-14-2.50	Standard	14mm	2.50"	1.61"	1.65"	S9/16-18X1/2
B3006-16-2.50	Standard	16mm	2.50"	1.61"	1.65"	S9/16-18X1/2
B3006-18-3.50	Standard	18mm	3.50"	1.65"	1.89"	S5/8-18X1/2
B3006-20-3.50	Standard	20mm	3.50"	1.65"	1.89"	S5/8-18X1/2
B3006-25-3.50	Standard	25mm	3.50"	2.36"	2.36"	S3/4-16X11/16(2)

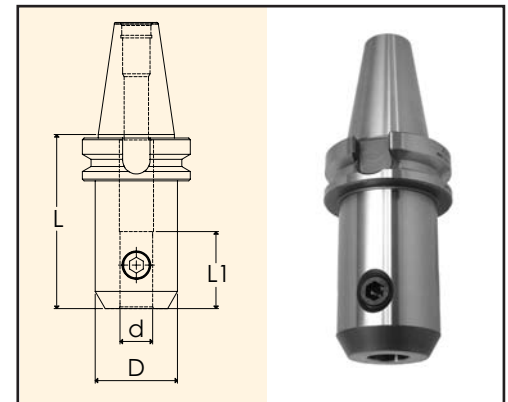

Set Screws are included. Back-up screws not included.

### Accessories:



**Set Screws**  
Page 28



**Set Screws for Aerospace Holders**  
Page 28



**Tool Jaw**  
Page 212



**Pull Stud**  
Pages 139-140