

## CAT and BT DA Collet Chucks

- Ground surface for perpendicular contact between retention knob and holder
- AT3 or better taper
- Equipped with a left-hand-threaded stop screw and chuck nut



**TIR:** minimal



**Speed:** up to 10,000 rpm



**Set-up:** quick and easy



**Coolant-thru:** none



**Drilling**  
★★★★☆



**Reaming**  
★★★★☆

Please note that the maximum RPM listed in our catalog may vary depending on the toolholder shank, weight, balanceability and the G rating.

### CAT40/50

Part Number	Taper	Collet Series 	Collet Range	L	L1	D
C4007-0100-3.50	CAT40	100DA	3/64-9/16"	3.50"	1.15"	1.06"
C4017-0100-6.00	CAT40	100DA	3/64-9/16"	6.00"	1.15"	1.06"
C4007-0180-4.00	CAT40	180DA	3/64-3/4"	4.00"	1.50"	1.44"
C4017-0180-6.00	CAT40	180DA	3/64-3/4"	6.00"	1.50"	1.44"
C4007-0200-3.00	CAT40	200DA	3/64-3/8"	3.00"	1.03"	0.86"
C4007-0300-3.00	CAT40	300DA	3/64-1/4"	3.00"	0.84"	0.55"
C5007-0180-4.00	CAT50	180DA	3/64-3/4"	4.00"	1.50"	1.44"
C5017-0180-6.00	CAT50	180DA	3/64-3/4"	6.00"	1.50"	1.44"

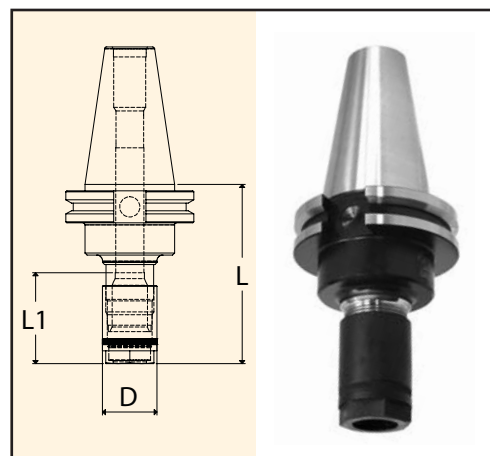

### BT30/40/50

Part Number	Taper	Collet Series 	Collet Range	L	L1	D
B3007-0100-3.00	BT30	100DA	3/64-9/16"	3.00"	1.15"	1.06"
B3007-0180-3.00	BT30	180DA	3/64-3/4"	3.00"	1.51"	1.44"
B3007-0200-3.00	BT30	200DA	3/64-3/8"	3.00"	1.03"	0.86"
B3007-0300-3.00	BT30	300DA	3/64-1/4"	3.00"	1.04"	0.55"
B4007-0100-3.50	BT40	100DA	3/64-9/16"	3.50"	1.15"	1.06"
B4017-0100-6.00	BT40	100DA	3/64-9/16"	6.00"	1.15"	1.06"
B4007-0180-4.00	BT40	180DA	3/64-3/4"	4.00"	1.51"	1.44"
B4017-0180-6.00	BT40	180DA	3/64-3/4"	6.00"	1.51"	1.44"
B4007-0200-3.00	BT40	200DA	3/64-3/8"	3.00"	1.03"	0.86"
B4007-0300-3.00	BT40	300DA	3/64-1/4"	3.00"	1.04"	0.55"
B5007-0180-4.00	BT50	180DA	3/64-3/4"	4.00"	1.51"	1.44"
B5017-0180-6.00	BT50	180DA	3/64-3/4"	6.00"	1.51"	1.44"

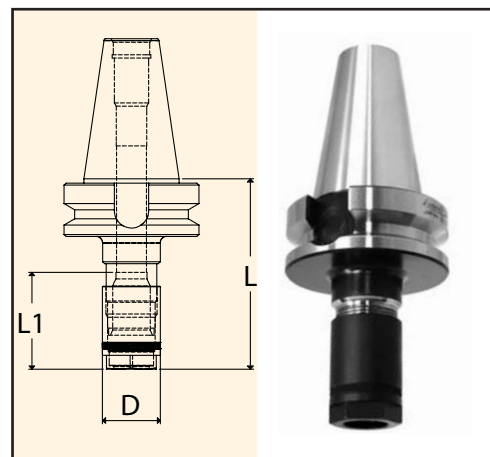

For light or medium milling, we recommend using ER or TG Collet Chucks. DA Collet Chucks are not designed for milling and can crack at the nose when over-tightened or radial load is applied. DA Collet Chucks are therefore not warranted against cracking.

#### Accessories:



**DA Collets**  
Pages 69-70



**DA Back Up Screw**  
Page 71



**DA Nut**  
Page 71