

## CAT and BT Blank Bars

- Taper ground to AT3 or better to ensure 80% taper contact
- Suitable for all applications – even deep boring
- Ground and hardened surfaces except projection of the toolholder



**TIR:** < .0002 run out along pilot



**Speed:** up to 15,000 rpm



**Set-up:** quick and easy



**Coolant-thru:** opt. modification

Please note that the maximum RPM listed in our catalog may vary depending on the toolholder shank, weight, balanceability and the G rating.

### CAT40/50

Part Number	Taper	L	D
C4008-0013	CT40	13.00"	2.50"
C5008-0013	CT50	13.00"	3.88"

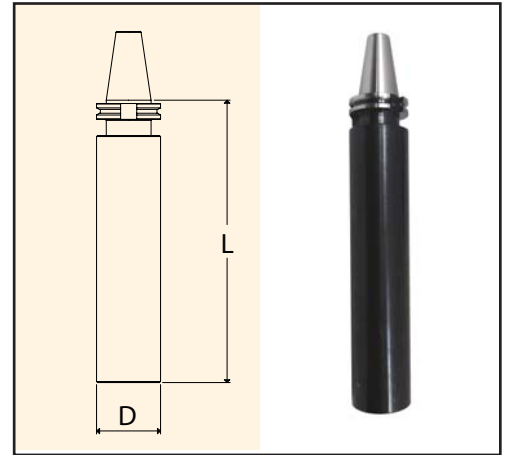

### BT30/40/50

Part Number	Taper	L	D
B3008-0008	BT30	8.00"	2.25"
B4008-0013	BT40	13.00"	2.50"
B5008-0013	BT50	13.00"	3.88"

