









BT MMC Collet Chucks

- No nut required. Slim, compact nose and front clamping allow greater rigidity and precision gripping
- High concentricity and repeatability
- Easy-to-use draw-in collet clamping pulled by standard side wrench
- Pre-balanced for high-speed applications

Please note that the maximum RPM listed in our catalog may vary depending on the toolholder shank, weight, balanceability and the G rating.

	TIR: 0.00012 or better		Drilling ★☆☆☆☆
	Speed: up to 30,000 rpm		Milling ★★★★☆
	Set-up: quick and easy to operate		Reaming ★★★★☆
	Coolant-thru: thru tool coolant		

BT30/40/50

Part Number	Taper	Coolant-thru	Collet Series 	Wrench	L	L1	D
BT30-MMC4-105	BT30	-	MPK4	Wrench-ALLEN6	4.134"	1.181"	0.591"
BT30-MMC8C-75-A	BT30	yes	VMK8	Wrench-THEX5	2.893"	1.476"	0.787"
BT30-MMC8-105	BT30	-	VMK8	Wrench-ALLEN6	4.134"	1.417"	0.787"
BT30-MMC12-105	BT30	-	VMK12	Wrench-ALLEN6	4.134"	1.378"	1.181"
BT40-MMC4-90	BT40	-	MPK4	Wrench-ALLEN6	3.543"	1.181"	0.591"
BT40-MMC8C-90	BT40	yes	VMK8	Wrench-ALLEN6	3.543"	1.417"	0.787"
BT40-MMC8C-120	BT40	yes	VMK8	Wrench-ALLEN6	4.724"	1.693"	0.787"
BT40-MMC12C-90	BT40	yes	VMK12	Wrench-ALLEN6	3.543"	1.378"	1.181"
BT40-MMC12C-120	BT40	yes	VMK12	Wrench-ALLEN6	4.724"	2.362"	1.181"
BT50-MMC4-105	BT50	-	MPK4	Wrench-ALLEN6	4.134"	1.181"	0.591"
BT50-MMC8C-105	BT50	yes	VMK8	Wrench-ALLEN6	4.134"	1.417"	0.787"
BT50-MMC8C-135	BT50	yes	VMK8	Wrench-ALLEN6	5.315"	1.693"	0.787"
BT50-MMC8C-165	BT50	yes	VMK8	Wrench-ALLEN6	6.496"	1.693"	0.787"
BT50-MMC12C-105	BT50	yes	VMK12	Wrench-ALLEN6	4.134"	1.378"	1.181"
BT50-MMC12C-135	BT50	yes	VMK12	Wrench-ALLEN6	5.315"	2.362"	1.181"
BT50-MMC12C-165	BT50	yes	VMK12	Wrench-ALLEN6	6.496"	2.756"	1.181"

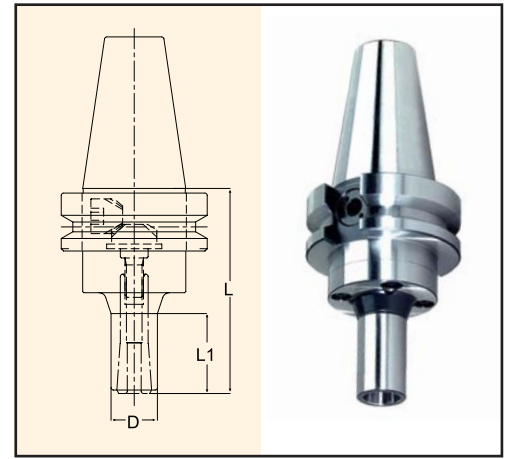

A Style MMC Chuck

Note: wrench included with holder except for BT-30-MMC8C-75-A.



3-Lock MMC Collet Chucks for Dual Contact Spindle

3-Lock MMC Collet Chucks are available from stock and feature Nikken unique Triple Contact System. Please refer to page 239 in our technical section to learn more about Nikken's revolutionary 3-Lock System and tooling line.

For a complete list of part numbers and pricing, please contact our office at (800) 543-6237



Accessories:



MPK and VMK Collets
Page 210



Tool Jaw
Page 212



Pull Stud
Pages 139-140