



Milling Chucks

Shrink Fit Holders

SK Collet Chucks



Current Promotion

Scan
these
QR Codes



Featured Video

SK Collet Chuck Features

LEAN, TOUGH AND EFFICIENT

- Lean:** narrow body design accesses tight spots
- Versatile:** applicable for all milling, drilling, reaming and rigid tapping applications
- Flexible:** covers sizes from .027" to 1"
- Accurate:** two times more accurate than ER Collet Chucks, within 10 times better repeatability
- Extremely Precise:** 0.00012" or less concentricity guarantee with on-size collets all the time
- 8° versus 16° collet taper:** twice more gripping power than ER Collet Chucks
- Extremely Successful:** over 1 million SK Collet Chucks and 15 million SK collets sold worldwide



SK Collet Range



SK6

(0.7-6.0mm)
(0.027-0.236")



SK10

(1.75-10.0mm)
(0.069-0.393")



SK16

(2.75-16.0mm)
(0.108-0.629")



SK25

(16.0-25.4mm)
(0.629-1.000")

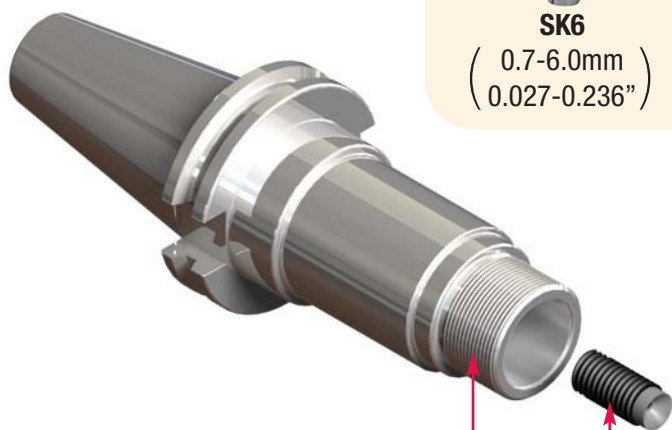

Grinding of threads allows accurate and strong collet compression and prevents collet rocking.

Fine adjustment back up screw (see detailed next page) and chamfered plastic tip creates additional seal for 1000PSI coolant through applications.

Accuracy and Flexibility

Due to Nikken's special heat treatment, grinding and custom slotting process, they are the only collet chuck manufacturer in the world that guarantees a 3 micron runout tolerance for their "on size" fractional and metric size precision collets.

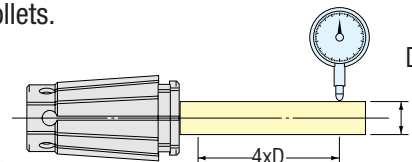

- Collet edge is flush with front surface of nut maximizing gripping rigidity
- Extreme hard and smooth surface of the TiN Bearing allows for more thrust load on the collet while preventing additional runout associated with collet twisting
- Threads are protected to prevent chip packing or stringy birds nests below the collet chuck nut

SK Collet Chuck Features

Increased Gripping Power

The smaller the taper angle is, the better concentricity is obtained.

Our steep 8° collet seats deeper in the body of the holder, providing twice more clamping force and twice more precision than traditional 16° ER collets.

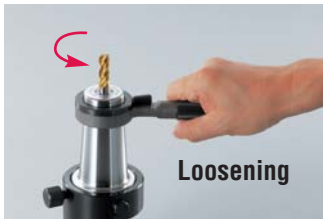

GH Handle

Easy, safe and reliable handling with GH wrench (see page 193).

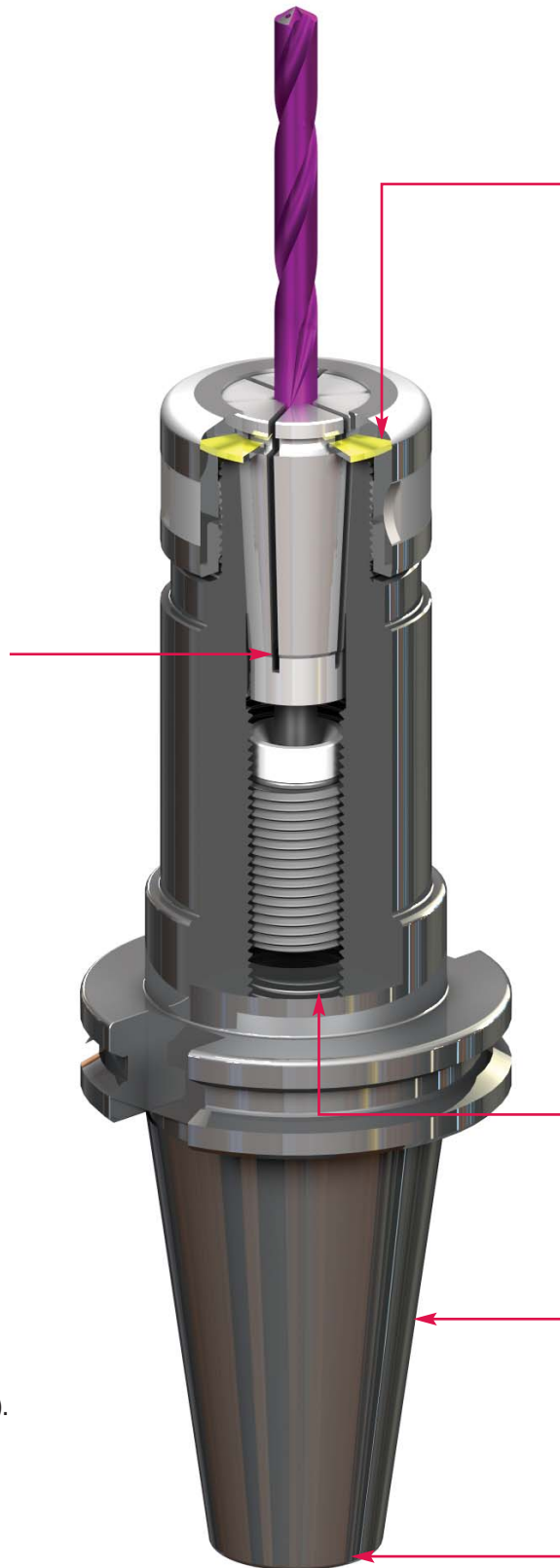

Titanium Nitrided Bearing Nut (HV2,200)

(US Patent 6923451)

- More efficient than conventional ball bearing built-in nut!
- Good sliding effect due to surface hardness of HV2,200
- No damage, no friction
- No corrosion occurs internally
- Less micro vibration with collet flange contact
- Increase cutting performance and tool life durability
- More cutting rigidity

High pressure 1200 PSI fine thread coolant back up screw

AT3 or better taper - .0028 degree tolerance variation (80 millionths to 126 millionths taper size tolerance)

Ground surface for accurate perpendicular contact between pull stud and taper

SK Collet

SK Collets can be used for all applications, from milling to reaming. Standard collets can be used in coolant thru applications (with coolant back-up screws).

SK Collet VS ER Collet

- A. Slim design allows for clearance
- B. Force is perpendicular to centerline of toolholder for strong grip
- C. Deep position creates greater accuracy
- D. Rigid body is flush with nut to maintain rigidity throughout

- A. Wide collets= wide nut design
- B. Force is angular to centerline of toolholder
- C. Shallow position creates collet rocking
- D. Body diameter is smaller than nut compromising rigidity

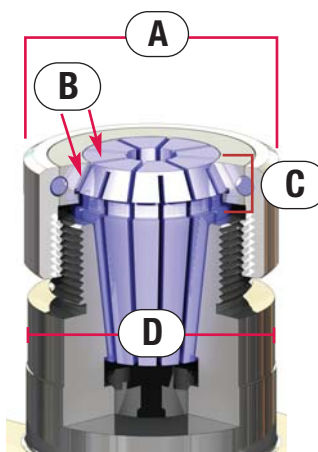
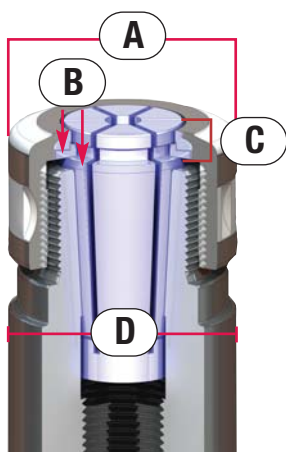

Lyndex-Nikken Slim Chuck -Flat shoulder pushing

Standard Collet can be used for High Pressure Coolant System

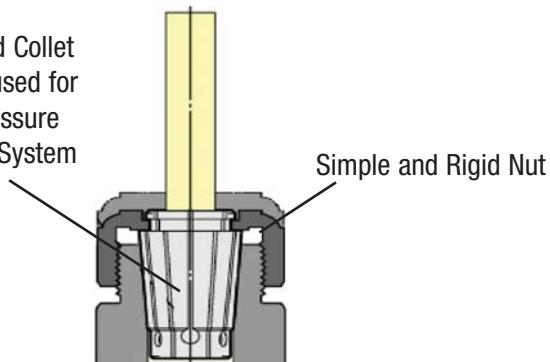

- High Accuracy Due to Flat Shoulder Pushing
- High Gripping Torque of 8° taper

Others -Taper shoulder pushing

Complicated Nut Balancing will be changed at High Speed Rotation

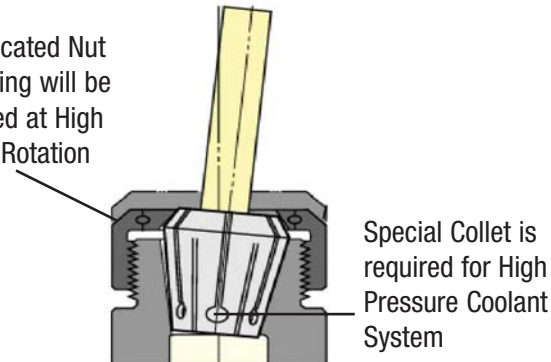

- Unstable Run-out Due to Taper Part Pushing
- Poor Gripping Torque of 12°, 16° taper

Superior SK Coolant System

Our Slim Chuck features a unique High-Pressure Coolant Collet System which allows for higher accuracy and gripping torque.

SK Coolant thru options:

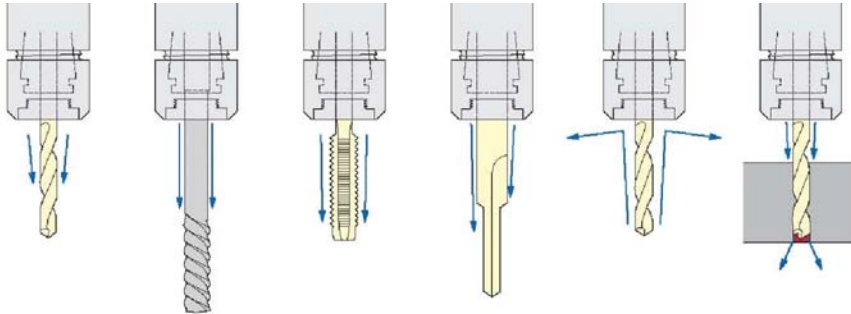

Slotted Disc:

When the Coolant Nut is paired with the Slotted Disc, coolant is directed to the cutting edge of the cutting tool, making this combination **ideal for non-coolant-thru tools**. The jet coolant pressure creates a tornado effect, ensuring **efficient swarf dispersal**.

Back-up Screw for SK Collet Chuck

SKG12



- Solid steel black oxide coated back up screws
- Accessible and adjustable from both ends

SKG-12L



- Excellent for high feed drilling
- Allows cutter repeatability within .0002"

SKG16-12HGA



- Ultra High Pressure back up screw capable up to 1200 psi
- Solid steel black oxide coated back up screws with plastic caps
- 80% thread engagement on fine thread to prevent coolant leakage
- External O ring provides additional seals to prevent coolant build up within the toolholder

SKG-18H



- Plastic cap is chamfered to accommodate for different sizes
- Excellent for high pressure coolant or oil drilling applications
- Allows cutter repeatability within .0002"



Applications for SK J Type Nut:

- Tap or specially designed cutting tool
- Burnishing drill for formed hole
- Oil hole drill for through hole drilling
- Cutting tool with coolant grooves
- Mechanical seal prevents dust and swarf entering inside the collet slots



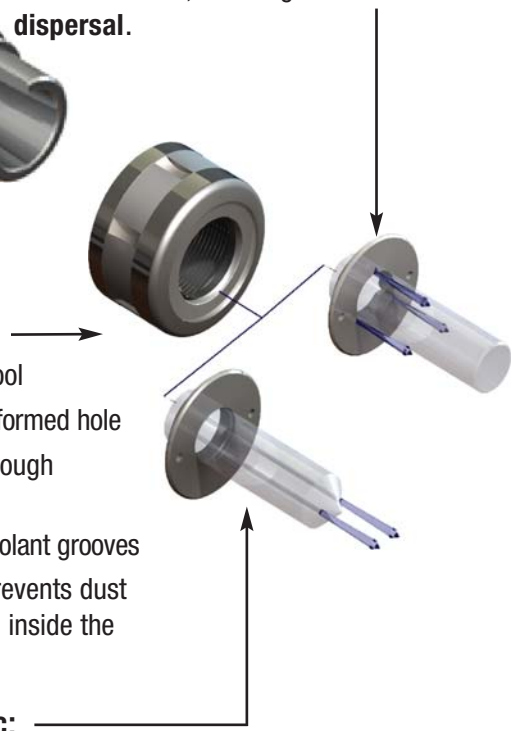

Coolant-Thru Disc:

When the Coolant Nut is paired with the Coolant-Thru Disk, **a perfect seal** is formed around the cutting tool shank, making this combination **ideal for coolant-thru tools**.



CAT SK Collet Chucks

- Feature TiN Bearing Nut which considerably improves cutting rigidity and finish
- Narrow body allows access to tight spaces and hard to reach areas
- Unique high-pressure coolant collet system for higher accuracy and gripping torque
- 8° taper SK collet provides twice more clamping force and precision than ER Collet Chucks

-  **TIR:** 0.0002" at 4xD
-  **Speed:** up to 30,000 rpm
-  **Set-up:** quick and easy
-  **Coolant-thru:** thru-tool coolant

-  **Drilling**
★★★★☆
-  **Milling**
★★★★☆
-  **Reaming**
★★★★☆

Please note that the maximum RPM listed in our catalog may vary depending on the toolholder shank, weight, balanceability and the G rating.

CAT40

Part Number	Collet Size	Wrench	L	L1	H	D	Back-up Screw
CAT40-SK6-90U	SK6	SKL-6W	3.543"	1.969"	0.827-1.378"	0.768"	SKG-8
CAT40-SK6-120U	SK6	SKL-6W	4.724"	2.441"	0.827-1.378"	0.768"	SKG-8
CAT40-SK6-150U	SK6	SKL-6W	5.906"	2.362"	0.827-1.378"	0.768"	SKG-8
CAT40-SK10-90U	SK10	SKL-10	3.543"	1.969"	1.181-1.969"	1.083"	SKG-12L
CAT40-SK10-120U	SK10	SKL-10	4.724"	2.756"	1.181-1.969"	1.083"	SKG-12L
CAT40-SK10-150U	SK10	SKL-10	5.906"	2.874"	1.181-1.969"	1.083"	SKG-12L
CAT40-SK10-180U	SK10	SKL-10	7.086"	2.874"	1.378-1.614"	1.083"	SKG-12L
CAT40-SK16-90U	SK16	9HC16	3.543"	1.969"	1.772-2.756"	1.575"	SKG-18L
CAT40-SK16-120U	SK16	9HC16	4.724"	3.150"	1.772-2.756"	1.575"	SKG-18L
CAT40-SK16-150U	SK16	9HC16	5.906"	4.331"	1.772-2.756"	1.575"	SKG-18L
CAT40-SK16-180U	SK16	9HC16	7.086"	5.710"	1.654-2.244"	1.575"	SKG-18L
CAT40-SK25-90U	SK25	9HC22	3.543"	2.165"	2.165-2.756"	2.165"	SKG-28
CAT40-SK25-120U	SK25	9HC22	4.724"	3.346"	2.165-3.346"	2.165"	SKG-28

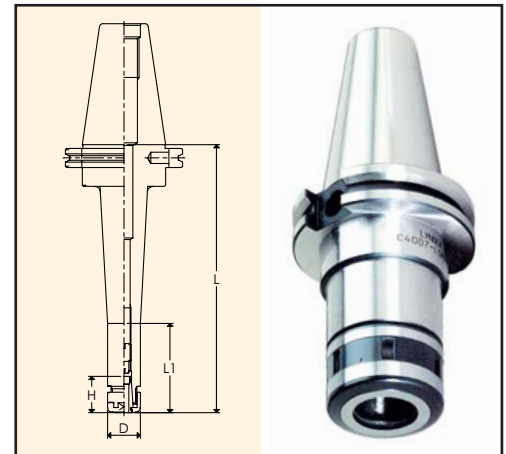

CAT50

Part Number	Collet Size	Wrench	L	L1	H	D	Back-up Screw
CAT50-SK6-105U	SK6	SKL-6W	4.134"	2.362"	0.827-1.378"	0.768"	SKG-8
CAT50-SK6-165U	SK6	SKL-6W	6.496"	2.441"	0.827-1.378"	0.768"	SKG-8
CAT50-SK6-195U	SK6	SKL-6W	7.677"	2.362"	0.827-1.378"	0.768"	SKG-8
CAT50-SK10-105U	SK10	SKL-10	4.134"	2.362"	1.181-1.969"	1.083"	SKG-12L
CAT50-SK10-165U	SK10	SKL-10	6.496"	2.953"	1.181-1.969"	1.083"	SKG-12L
CAT50-SK10-195U	SK10	SKL-10	7.677"	2.953"	1.181-1.969"	1.083"	SKG-12L
CAT50-SK10-225U	SK10	SKL-10	8.858"	2.953"	1.378-1.614"	1.083"	SKG-12L
CAT50-SK16-105U	SK16	9HC16	4.134"	2.559"	1.772-2.756"	1.575"	SKG-18L
CAT50-SK16-165U	SK16	9HC16	6.496"	3.543"	1.772-2.756"	1.575"	SKG-18L
CAT50-SK16-195U	SK16	9HC16	7.677"	3.543"	1.772-2.756"	1.575"	SKG-18L
CAT50-SK25-105U	SK25	9HC22	4.134"	2.559"	2.165-3.346"	2.165"	SKG-28
CAT50-SK25-165U	SK25	9HC22	6.496"	4.921"	2.165-3.346"	2.165"	SKG-28
CAT50-SK25-195U	SK25	9HC22	7.677"	6.102"	2.165-3.346"	2.165"	SKG-28

Note: Wrench and back-up screw not included.

3-Lock SK Collet Chucks for Dual Contact Spindle

3-Lock SK Collet Chucks are available from stock and feature Nikken unique Triple Contact System. Please refer to page 239 in our technical section to learn more about Nikken's revolutionary 3-Lock System and tooling line.

For a complete list of part numbers and pricing, please contact our office at (800) 543-6237



Accessories:



SK Collets
Page 188



Wrench
Page 193



Back-up screw
Page 194



Coolant-thru and Slotted Nuts
Page 192

CAT SK Collet Chucks

CAT40 - DIN

Part Number	Collet Size	Wrench	L	L1	H	D	Back-up Screw
CAT40-SK6F-90U	SK6	SKL-6W	3.543"	1.969"	0.827-1.378"	0.768"	SKG6-6HG
CAT40-SK6F-120U	SK6	SKL-6W	4.724"	2.441"	0.827-1.378"	0.768"	SKG6-6HG
CAT40-SK6F-150U	SK6	SKL-6W	5.906"	2.362"	0.827-1.378"	0.768"	SKG6-6HG
CAT40-SK10F-90U	SK10	SKL-10	3.543"	1.969"	1.181-1.969"	1.083"	SKG10-10HG
CAT40-SK10F-120U	SK10	SKL-10	4.724"	2.756"	1.181-1.969"	1.083"	SKG10-10HG
CAT40-SK10F-150U	SK10	SKL-10	5.906"	2.874"	1.181-1.969"	1.083"	SKG10-10HG
CAT40-SK16F-60U	SK16	9HC16	2.362"	1.181"	1.772-2.756"	1.575"	N/A
CAT40-SK16F-90U	SK16	9HC16	3.543"	1.969"	1.772-2.756"	1.575"	SKG16-12HG
CAT40-SK16F-120U	SK16	9HC16	4.724"	3.150"	1.772-2.756"	1.575"	SKG16-12HG
CAT40-SK16F-150U	SK16	9HC16	5.906"	4.331"	1.772-2.756"	1.575"	SKG16-12HG
CAT40-SK25F-90U	SK25	9HC22	3.543"	2.165"	2.165-2.756"	2.165"	SKG25-18HGE
CAT40-SK25F-120U	SK25	9HC22	4.724"	3.346"	2.165-3.346"	2.165"	SKG25-18HGE

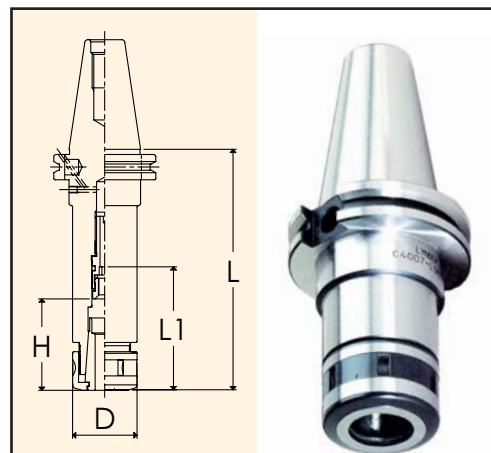

CAT40 - DIN Note: Wrench and back-up screw not included. No back adjustment screw.

CAT40 High-Speed

Part Number	Collet	Wrench	L	L1	H	D	Back-up Screw
CAT40-SK6-90UP	SK6	GH6	3.543"	2.165"	0.827"-1.378"	0.768"	SKG-8
CAT40-SK6-120UP	SK6	GH6	4.724"	2.637"	0.827"-1.378"	0.768"	SKG-8
CAT40-SK6-150UP	SK6	GH6	5.906"	4.528"	0.827"-1.378"	0.768"	SKG-8
CAT40-SK10-90UP	SK10	GH10	3.543"	2.165"	1.181"-1.969"	1.083"	SKG-12L
CAT40-SK10-120UP	SK10	GH10	4.724"	3.346"	1.181"-1.969"	1.083"	SKG-12L
CAT40-SK10-150UP	SK10	GH10	5.906"	4.528"	1.181"-1.969"	1.083"	SKG-12L
CAT40-SK16-60UP	SK16	GH16	2.362"	1.181"	1.574"-2.756"	1.575"	N/A
CAT40-SK16-90UP	SK16	GH16	3.543"	2.165"	1.574"-2.756"	1.575"	SKG-18L
CAT40-SK16-120UP	SK16	GH16	4.724"	3.346"	1.574"-2.756"	1.575"	SKG-18L
CAT40-SK16-150UP	SK16	GH16	5.906"	4.528"	1.574"-2.756"	1.575"	SKG-18L
CAT40-SK25-90UP	SK25	GH25	3.543"	2.165"	2.165"-2.952"	2.165"	SKG-28
CAT40-SK25-120UP	SK25	GH25	4.724"	3.346"	2.165"-2.952"	2.165"	SKG-28

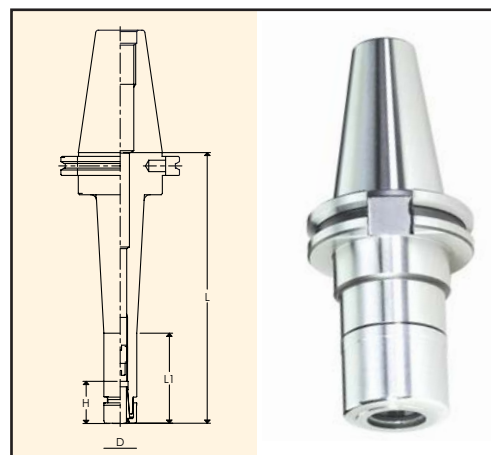

CAT40 - High-Speed Note: No back adjustment screw. DIN type high-speed toolholders available. Please contact us for more information.

CAT50 High-Speed

Part Number	Collet Size	Wrench	L	L1	H	D	Back-up Screw
CAT50-SK6-105UP	SK6	GH6	4.134"	2.756"	0.827"-1.378"	0.768"	SKG-8
CAT50-SK6-165UP	SK6	GH6	6.496"	5.118"	0.827"-1.378"	0.768"	SKG-8
CAT50-SK10-105UP	SK10	GH10	4.134"	2.756"	1.181"-1.969"	1.083"	SKG-12L
CAT50-SK10-165UP	SK10	GH10	6.496"	5.118"	1.181"-1.969"	1.083"	SKG-12L
CAT50-SK10-195UP	SK10	GH10	7.677"	6.299"	1.181"-1.969"	1.083"	SKG-12L
CAT50-SK16-105UP	SK16	GH16	4.134"	2.756"	1.574"-2.756"	1.575"	SKG-18L
CAT50-SK16-165UP	SK16	GH16	6.496"	5.118"	1.574"-2.756"	1.575"	SKG-18L
CAT50-SK16-195UP	SK16	GH16	7.677"	6.299"	1.574"-2.756"	1.575"	SKG-18L
CAT50-SK25-105UP	SK25	GH25	4.134"	2.756"	2.165"-2.952"	2.165"	SKG-28
CAT50-SK25-165UP	SK25	GH25	6.496"	5.118"	2.165"-2.952"	2.165"	SKG-28
CAT50-SK25-195UP	SK25	GH25	7.677"	6.299"	2.165"-2.952"	2.165"	SKG-28

CAT50 - High-Speed Note: Wrench and back-up screw not included.

Accessories:



SK Collets
Page 188



Wrench
Page 193



Back-up screw
Page 194



Coolant-thru and
Slotted Nuts
Page 192

BT SK Collet Chucks

- Feature TiN Bearing Nut which considerably improves cutting rigidity and finish
- Narrow body allows access to tight spaces and hard to reach areas
- Unique high-pressure coolant collet system for higher accuracy and gripping torque
- 8° taper SK collet provides twice more clamping force and precision than ER Collet Chucks



TIR: 0.0002" at 4xD



Speed: up to 30,000 rpm



Set-up: quick and easy



Coolant-thru: thru-tool coolant



Drilling
★★★★☆



Milling
★★★★☆



Reaming
★★★★☆

Please note that the maximum RPM listed in our catalog may vary depending on the toolholder shank, weight, balanceability and the G rating.

BT30

Part Number	Collet Size	Wrench	L	L1	H	D	Back-up Screw
BT30-SK6-60	SK6	SKL-6W	2.362"	1.299"	0.827-1.378"	0.768"	SKG-8
BT30-SK6-90	SK6	SKL-6W	3.543"	2.205"	0.827-1.378"	0.768"	SKG-8
BT30-SK10-45	SK10	SKL-10	1.772"	0.866"	1.181-1.969"	1.083"	SKG-12S
BT30-SK10-60	SK10	SKL-10	2.362"	1.378"	1.181-1.969"	1.083"	SKG-12L
BT30-SK10-90	SK10	SKL-10	3.543"	2.559"	1.181-1.969"	1.083"	SKG-12L
BT30-SK16-60	SK16	9HC16	2.362"	1.457"	1.772-2.362"	1.575"	SKG-12L
BT30-SK16-90	SK16	9HC16	3.543"	2.638"	1.772-2.559"	1.575"	SKG-12
BT30-SK25-90	SK25	9HC22	3.543"	2.559"	2.165-2.953"	2.165"	SKG-12

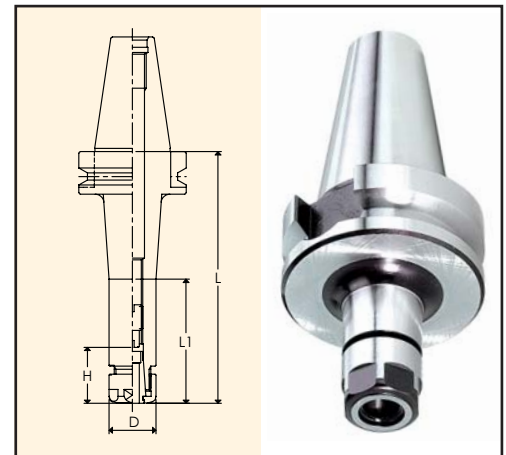

BT40

Part Number	Collet Size	Wrench	L	L1	H	D	Back-up Screw
BT40-SK6-90	SK6	SKL-6W	3.543"	2.008"	0.827-1.378"	0.768"	SKG-8
BT40-SK6-120	SK6	SKL-6W	4.724"	2.362"	0.827-1.378"	0.768"	SKG-8
BT40-SK6-150	SK6	SKL-6W	5.906"	2.362"	0.827-1.378"	0.768"	SKG-8
BT40-SK10-90	SK10	SKL-10	3.543"	1.890"	1.181-1.969"	1.083"	SKG-12L
BT40-SK10-120	SK10	SKL-10	4.724"	2.874"	1.181-1.969"	1.083"	SKG-12L
BT40-SK10-150	SK10	SKL-10	5.906"	2.874"	1.181-1.969"	1.083"	SKG-12L
BT40-SK10-180	SK10	SKL-10	7.086"	-	1.378-1.614"	1.083"	SKG-12L
BT40-SK16-90	SK16	9HC16	3.543"	2.283"	1.772-2.756"	1.575"	SKG-18L
BT40-SK16-120	SK16	9HC16	4.724"	3.465"	1.772-2.756"	1.575"	SKG-18L
BT40-SK16-150	SK16	9HC16	5.906"	4.646"	1.772-2.756"	1.575"	SKG-18L
BT40-SK16-180	SK16	9HC16	7.086"	6.023"	1.654-2.244"	1.575"	SKG-18L
BT40-SK25-75	SK25	9HC22	2.953"	1.850"	2.165-2.953"	2.165"	SKG-12
BT40-SK25-90	SK25	9HC22	3.543"	2.402"	2.165-2.953"	2.165"	SKG-28
BT40-SK25-120	SK25	9HC22	4.724"	3.583"	2.165-3.346"	2.165"	SKG-28

Note: Wrench and back-up screw not included.

Accessories:



SK Collets
Page 188



Wrench
Page 193



Back-up screw
Page 194



Coolant-thru and Slotted Nuts
Page 192

BT SK Collet Chucks

BT50

Part Number	Collet Size	Wrench	L	L1	H	D	Back-up Screw
BT50-SK6-105	SK6	SKL-6W	4.134"	2.165"	0.827-1.378"	0.768"	SKG-8
BT50-SK6-165	SK6	SKL-6W	6.496"	2.362"	0.827-1.378"	0.768"	SKG-8
BT50-SK6-195	SK6	SKL-6W	7.677"	2.362"	0.827-1.378"	0.768"	SKG-8
BT50-SK10-105	SK10	SKL-10	4.134"	2.244"	1.181-1.969"	1.083"	SKG-12L
BT50-SK10-165	SK10	SKL-10	6.496"	2.953"	1.181-1.969"	1.083"	SKG-12L
BT50-SK10-195	SK10	SKL-10	7.677"	2.953"	1.181-1.969"	1.083"	SKG-12L
BT50-SK16-105	SK16	9HC16	4.134"	2.441"	1.772-2.756"	1.575"	SKG-18L
BT50-SK16-165	SK16	9HC16	6.496"	3.543"	1.772-2.756"	1.575"	SKG-18L
BT50-SK16-195	SK16	9HC16	7.677"	3.543"	1.772-2.756"	1.575"	SKG-18L
BT50-SK25-105	SK25	9HC22	4.134"	2.441"	2.165-3.346"	2.165"	SKG-28
BT50-SK25-165	SK25	9HC22	6.496"	4.803"	2.165-3.346"	2.165"	SKG-28
BT50-SK25-195	SK25	9HC22	7.677"	5.984"	2.165-3.346"	2.165"	SKG-28

Note: Wrench and back-up screw not included.

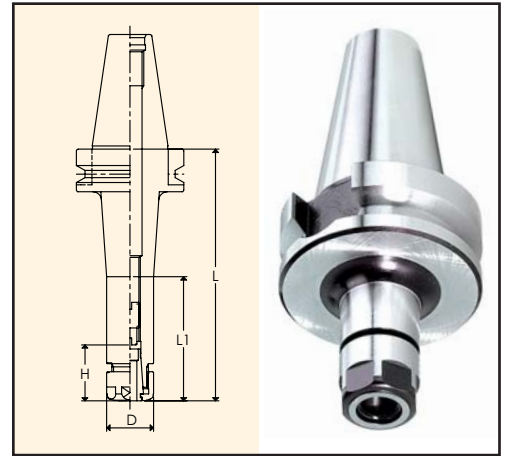

Accessories:



SK Collets
Page 188



Wrench
Page 193



Back-up screw
Page 194



Coolant-thru and Slotted Nuts
Page 192

BT SK Collet Chucks - High Speed

BT30 High-Speed

Part Number	Collet Size	Wrench	L	L1	H	D	Back-up Screw
BT30-SK6-60P	SK6	GH6	2.362"	1.496"	0.827" - 1.378"	0.768"	SKG-8
BT30-SK6-90P	SK6	GH6	3.543"	2.480"	0.827" - 1.378"	0.768"	SKG-8
BT30-SK10-45P	SK10	GH10	1.772"	0.906"	1.181" - 1.969"	1.083"	SKG-12S
BT30-SK10-60P	SK10	GH10	2.362"	2.677"	1.181" - 1.969"	1.083"	SKG-12L
BT30-SK10-90P	SK10	GH10	3.543"	1.496"	1.181" - 1.969"	1.083"	SKG-12L
BT30-SK16-60P	SK16	GH16	2.362"	1.496"	1.772" - 2.362"	1.575"	SKG-12L
BT30-SK16-90P	SK16	GH16	3.543"	2.677"	1.772" - 2.559"	1.575"	SKG-12
BT30-SK25-90P	SK25	GH25	3.543"	1.693"	2.165" - 2.953"	2.165"	SKG-28

BT40 High-Speed

Part Number	Collet Size	Wrench	L	L1	H	D	Back-up Screw
BT40-SK6-90P	SK6	GH6	3.543"	2.086"	0.827" - 1.378"	0.768"	SKG-8
BT40-SK6-120P	SK6	GH6	4.724"	3.661"	0.827" - 1.378"	0.768"	SKG-8
BT40-SK6-150P	SK6	GH6	5.906"	4.843"	0.827" - 1.378"	0.768"	SKG-8
BT40-SK10-90P	SK10	GH10	3.543"	2.480"	1.181" - 1.969"	1.083"	SKG-12L
BT40-SK10-120P	SK10	GH10	4.724"	3.661"	1.181" - 1.969"	1.083"	SKG-12L
BT40-SK10-150P	SK10	GH10	5.906"	2.874"	1.181" - 1.969"	1.083"	SKG-12L
BT40-SK16-90P	SK16	GH16	3.543"	2.480"	1.575" - 2.756"	1.575"	SKG-18L
BT40-SK16-120P	SK16	GH16	4.724"	3.661"	1.575" - 2.756"	1.575"	SKG-18L
BT40-SK16-150P	SK16	GH16	5.906"	4.646"	1.575" - 2.756"	1.575"	SKG-18L
BT40-SK25-75P	SK25	GH25	2.953"	1.890"	2.165" - 2.953"	2.165"	SKG-12
BT40-SK25-90P	SK25	GH25	3.543"	2.480"	2.165" - 2.953"	2.165"	SKG-28
BT40-SK25-120P	SK25	GH25	4.724"	3.661"	2.165" - 2.953"	2.165"	SKG-28

BT50 High-Speed

Part Number	Collet Size	Wrench	L	L1	H	D	Back-up Screw
BT50-SK6-105P	SK6	GH6	4.134"	2.638"	0.827" - 1.378"	0.768"	SKG-8
BT50-SK6-165P	SK6	GH6	6.496"	5.00"	0.827" - 1.378"	0.768"	SKG-8
BT50-SK6-195P	SK6	GH6	7.677"	2.362"	0.827" - 1.378"	0.768"	SKG-8
BT50-SK10-105P	SK10	GH10	4.134"	2.638"	1.181" - 1.969"	1.083"	SKG-12L
BT50-SK10-165P	SK10	GH10	6.496"	5.00"	1.181" - 1.969"	1.083"	SKG-12L
BT50-SK10-195P	SK10	GH10	7.677"	6.181"	1.181" - 1.969"	1.083"	SKG-12L
BT50-SK16-105P	SK16	GH16	4.134"	2.638"	1.575" - 2.756"	1.575"	SKG-18L
BT50-SK16-165P	SK16	GH16	6.496"	5.00"	1.575" - 2.756"	1.575"	SKG-18L
BT50-SK16-195P	SK16	GH16	7.677"	3.543"	1.575" - 2.756"	1.575"	SKG-18L
BT50-SK25-105P	SK25	GH25	4.134"	2.638"	2.165" - 2.953"	2.165"	SKG-28
BT50-SK25-165P	SK25	GH25	6.496"	5.00"	2.165" - 2.953"	2.165"	SKG-28
BT50-SK25-195P	SK25	GH25	7.677"	5.984"	2.165" - 2.953"	2.165"	SKG-28

Note: Wrench and back-up screw not included.

Accessories:



SK Collets
Page 188



Wrench
Page 193



Back-up screw
Page 194



Coolant-thru and Slotted Nuts
Page 192

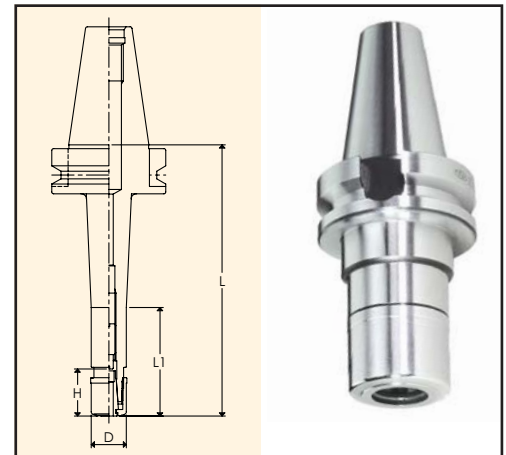

3-Lock SK Collet Chucks for Dual Contact Spindle

3-Lock SK Collet Chucks are available from stock and feature Nikken unique Triple Contact System. Please refer to page 239 in our technical section to learn more about Nikken's revolutionary 3-Lock System and tooling line.

For a complete list of part numbers and pricing, please contact our office at (800) 543-6237



Straight Shank SK Collet Chucks

- Feature TiN Bearing Nut which considerably improves cutting rigidity and finish
- Narrow body allows access to tight spaces and hard to reach areas
- Unique high-pressure coolant collet system for higher accuracy and gripping torque
- 8° taper SK collet provides twice more clamping force and precision than ER Collet Chucks



TIR: 0.0002" at 4xD



Speed: up to 30,000 rpm



Set-up: quick and easy



Coolant-thru: thru-tool coolant



Drilling
★★★★☆





Milling
★★★★☆



Reaming
★★★★☆

Please note that the maximum RPM listed in our catalog may vary depending on the toolholder shank, weight, balanceability and the G rating.

Straight Shank

Part Number	Collet Size 	Wrench 	H	D
K3/4-SK10-100	SK10	SKL-10	1.378-1.614"	1.083"
K3/4-SK10-120	SK10	SKL-10	1.378-1.614"	1.083"
K1.1/4-SK6-120	SK6	SKL-6W	0.827-1.378"	0.768"
K1.1/4-SK6-170	SK6	SKL-6W	0.827-1.378"	0.768"
K1.1/4-SK10-120	SK10	SKL-10	1.378-1.614"	1.083"
K1.1/4-SK10-150	SK10	SKL-10	1.378-1.614"	1.083"
K1.1/4-SK10-210	SK10	SKL-10	1.378-1.614"	1.083"
K1.1/4-SK16-120	SK16	9HC16	1.654-2.244"	1.575"
K1.1/4-SK16-150	SK16	9HC16	1.654-2.244"	1.575"
K1.1/4-SK16-210	SK16	9HC16	1.654-2.244"	1.575"
K1.1/4-SK25-150	SK25	9HC22	2.362-2.559"	2.165"

Note: Wrench and back-up screw not included.

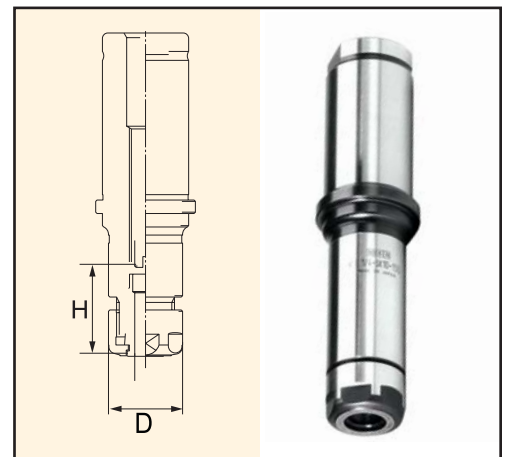

Accessories:



SK Collets
Page 188



Wrench
Page 193



Back-up screw
Page 194



Coolant-thru and Slotted Nuts
Page 192

HSK SK Collet Chucks

- Feature TiN Bearing Nut which considerably improves cutting rigidity and finish
- Narrow body allows access to tight spaces and hard to reach areas
- Unique high-pressure coolant collet system for higher accuracy and gripping torque
- 8° taper SK collet provides twice more clamping force and precision than ER Collet Chucks



TIR: 0.0002" at 4xD



Speed: up to 30,000 rpm



Set-up: quick and easy



Coolant-thru: thru-tool coolant



Drilling
★★★★☆



Milling
★★★★☆



Reaming
★★★★☆

Please note that the maximum RPM listed in our catalog may vary depending on the toolholder shank, weight, balanceability and the G rating.

HSK63A

Part Number	Collet Size	Wrench	L	L1	H	D	Back-up Screw
HSK63A-SK6C-100	SK6	SKL-6W	3.937"	2.441"	1.024-1.220"	0.768"	SKG6-6HG
HSK63A-SK6C-120	SK6	SKL-6W	4.724"	2.441"	1.024-1.220"	0.768"	SKG6-6HG
HSK63A-SK6C-150	SK6	SKL-6W	5.906"	2.362"	1.024-1.220"	0.768"	SKG6-6HG
HSK63A-SK10C-105	SK10	SKL-10	4.134"	2.913"	1.378-1.614"	1.083"	SKG10-10HG
HSK63A-SK10C-120	SK10	SKL-10	4.724"	2.362"	1.378-1.614"	1.083"	SKG10-10HG
HSK63A-SK10C-150	SK10	SKL-10	5.906"	2.874"	1.378-1.614"	1.083"	SKG10-10HG
HSK63A-SK16C-120	SK16	9HC16	4.724"	3.583"	1.772-2.047"	1.575"	SKG16-10HG
HSK63A-SK16C-150	SK16	9HC16	5.906"	4.764"	1.772-2.244"	1.575"	SKG16-12HG
HSK63A-SK25C-135	SK25	9HC22	5.315"	4.252"	2.362-2.559"	2.165"	SKG25-18HGE

Note: Wrench and back-up screw not included.
Coolant tube and coolant tube wrench are sold separately. See page 210 for details.

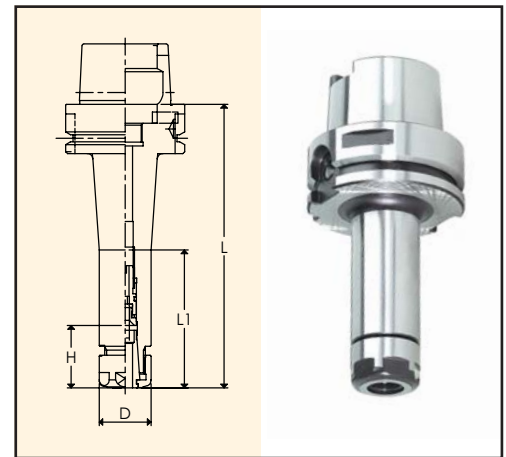

HSK100A

Part Number	Collet Size	Wrench	L	L1	H	D	Back-up Screw
HSK100A-SK6C-105	SK6	SKL-6W	4.134"	2.441"	1.024-1.220"	0.768"	SKG6-6HG
HSK100A-SK10C-105	SK10	SKL-10	4.134"	2.244"	1.378-1.614"	1.083"	SKG10-10HG
HSK100A-SK10C-120	SK10	SKL-10	4.724"	2.913"	1.378-1.614"	1.083"	SKG10-10HG
HSK100A-SK10C-150	SK10	SKL-10	5.906"	3.150"	1.378-1.614"	1.083"	SKG10-10HG
HSK100A-SK10C-200	SK10	SKL-10	7.874"	2.953"	1.378-1.614"	1.083"	SKG10-10HG
HSK100A-SK16C-120	SK16	9HC16	4.724"	3.386"	1.654-2.047"	1.575"	SKG16-10HG
HSK100A-SK16C-150	SK16	9HC16	5.906"	3.543"	1.654-2.244"	1.575"	SKG16-12HG
HSK100A-SK16C-200	SK16	9HC16	7.874"	3.543"	1.654-2.244"	1.575"	SKG16-12HG
HSK100A-SK25C-145	SK25	9HC22	5.709"	4.370"	2.362-2.559"	2.165"	SKG25-18HGE

Note: Wrench and back-up screw not included.
Coolant tube and coolant tube wrench are sold separately. See page 210 for details.

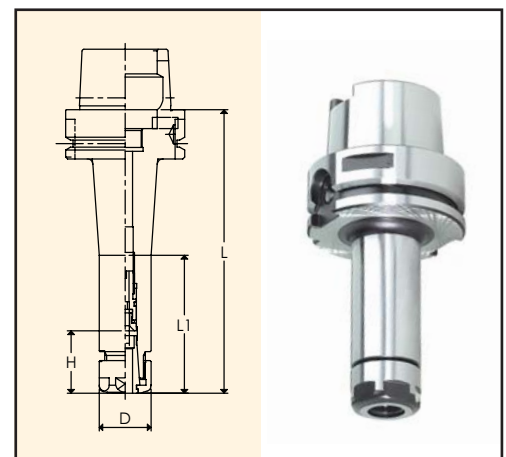

Accessories:



SK Collets
Page 188



Wrench
Page 193



Back-up screw
Page 194



Coolant-thru and Slotted Nuts
Page 192

HSK SK Collet Chucks - High Speed

HSK63A High-Speed



Part Number	Collet Size	Wrench	L	L1	H	D	Back-up Screw
HSK63A-SK6C-100P	SK6	GH6	3.937"	2.913"	1.024" - 1.220"	0.768"	SKG6-6HG
HSK63A-SK6C-120P	SK6	GH6	4.724"	3.700"	1.024" - 1.220"	0.768"	SKG6-6HG
HSK63A-SK6C-150P	SK6	GH6	5.906"	4.882"	1.024" - 1.220"	0.768"	SKG6-6HG
HSK63A-SK10C-105P	SK10	GH10	4.134"	3.110"	1.299" - 1.614"	1.083"	SKG10-10HG
HSK63A-SK10C-120P	SK10	GH10	4.724"	3.700"	1.299" - 1.614"	1.083"	SKG10-10HG
HSK63A-SK10C-150P	SK10	GH10	5.906"	4.882"	1.299" - 1.614"	1.083"	SKG10-10HG
HSK63A-SK16C-120P	SK16	GH16	4.724"	3.700"	1.772" - 2.047"	1.575"	SKG16-10HG
HSK63A-SK16C-150P	SK16	GH16	5.906"	4.882"	1.772" - 2.244"	1.575"	SKG16-12HG
HSK63A-SK25C-135P	SK25	GH25	5.315"	4.252"	2.362" - 2.559"	2.165"	SKG25-18HGE

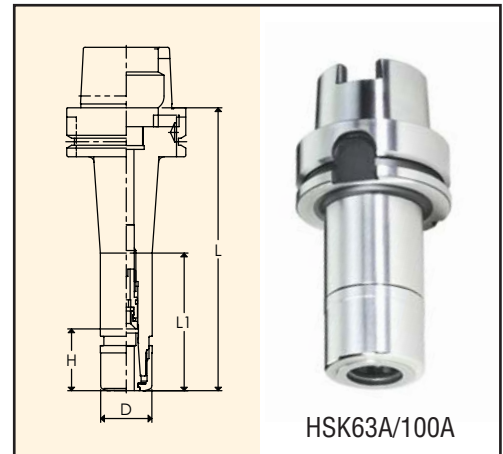

HSK100A High-Speed



Part Number	Collet Size	Wrench	L	L1	H	D	Back-up Screw
HSK100A-SK6C-105P	SK6	GH6	4.134"	2.637"	1.024" - 1.220"	0.768"	SKG6-6HG
HSK100A-SK10C-105P	SK10	GH10	4.134"	2.441"	1.299" - 1.614"	1.083"	SKG10-10HG
HSK100A-SK10C-120P	SK10	GH10	4.724"	3.031"	1.299" - 1.614"	1.083"	SKG10-10HG
HSK100A-SK10C-150P	SK10	GH10	5.906"	4.213"	1.299" - 1.614"	1.083"	SKG10-10HG
HSK100A-SK10C-200P	SK10	GH10	7.874"	6.732"	1.299" - 1.614"	1.083"	SKG10-10HG
HSK100A-SK16C-120P	SK16	GH16	4.724"	3.583"	1.771" - 2.047"	1.575"	SKG16-10HG
HSK100A-SK16C-150P	SK16	GH16	5.906"	3.740"	1.771" - 2.047"	1.575"	SKG16-12HG
HSK100A-SK16C-200P	SK16	GH16	7.874"	6.732"	1.771" - 2.047"	1.575"	SKG16-12HG
HSK100A-SK25C-145P	SK25	GH25	5.709"	4.567"	2.362" - 2.559"	2.165"	SKG25-18HGE

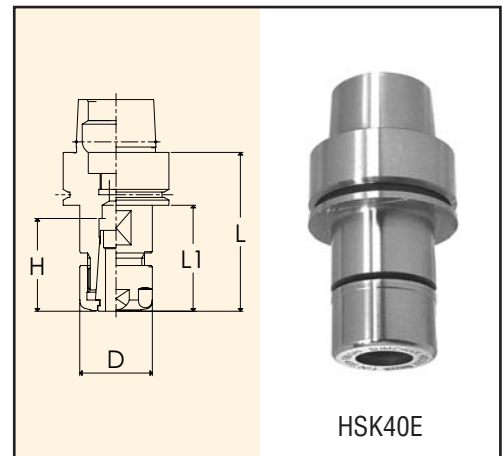

HSK32E and HSK40E High-Speed



Part Number	Collet Size	Wrench	L	L1	H	D	Back-up Screw
HSK32E-SK6-50P	SK6	GH6	1.969"	1.260"	1.024" - 1.142"	0.768"	SKG-5L
HSK32E-SK10-60P	SK10	GH10	2.362"	1.732"	1.142" - 1.417"	1.083"	SKG-6L
HSK40E-SK6-60P	SK6	GH6	2.362"	1.456"	1.024" - 1.142"	0.768"	SKG-5L
HSK40E-SK10-60P	SK10	GH10	2.362"	2.047"	1.142" - 1.417"	1.083"	SKG-6L
HSK40E-SK16-80P	SK16	GH16	3.149"	-	2.322"	1.575"	-

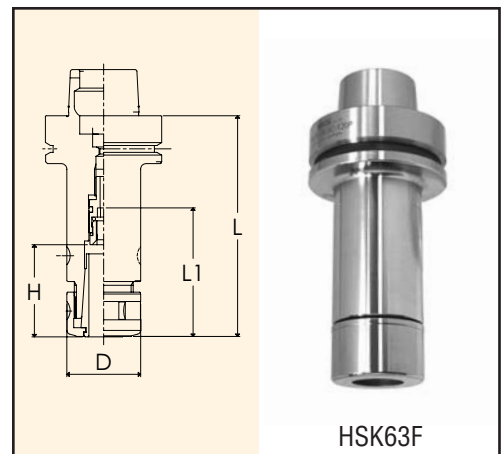

HSK63F High-Speed



Part Number	Collet Size	Wrench	L	L1	H	D	Back-up Screw
HSK63F-SK10C-105P	SK10	GH10	4.134"	2.913"	1.299" - 1.614"	1.083"	SKG10-10HG
HSK63F-SK16C-120P	SK16	GH16	4.724"	3.583"	2.637"	1.575"	SKG16-10HG

Note: Wrench and back-up screw not included.
Coolant tube and coolant tube wrench are sold separately. See page 210 for details.

Accessories:



SK Collets
Page 188



Wrench
Page 193



Back-up screw
Page 194



Coolant-thru and Slotted Nuts
Page 192

SK6 Collets

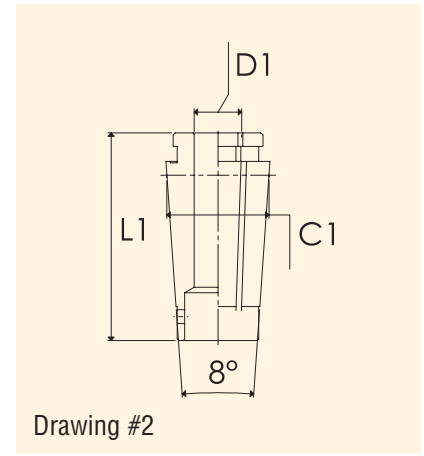
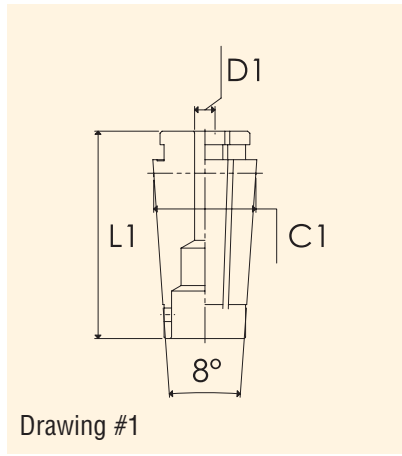

Dimensional Data

Collet Series	C1	L1	Collet Range (D1)
SK6	0.39" (10mm)	0.96" (24.6mm)	0.027-0.23" (0.7-6.0mm)
SK10	0.59" (15mm)	1.20" (30.5mm)	0.06-0.39" (1.75-10.0mm)
SK16	0.94" (24mm)	1.77" (45mm)	0.10-0.62" (2.75-16.0mm)
SK25	1.37" (35mm)	2.24" (57mm)	0.62-1.0" (16.0-25.4mm)

SK6 Collets - Metric

Part Number	Collapse Range (mm)	Collapse Range (")	Drawing #	
SK6-0.8	0.7-0.8	0.027-0.031"	#1	
SK6-1	0.9-1.0	0.035-0.039"		
SK6-1.25	1.15-1.25	0.045-0.049"		
SK6-1.5	1.3-1.5	0.051-0.059"		
SK6-1.75	1.5-1.75	0.059-0.068"		
SK6-2	1.8-2.0	0.070-0.078"		
SK6-2.25	2.05-2.25	0.080-0.088"		
SK6-2.5	2.3-2.5	0.090-0.098"		
SK6-2.75	2.55-2.75	0.100-0.108"		
SK6-3	2.8-3.0	0.110-0.118"		
SK6-3.5	3.0-3.5	0.118-0.137"		#2
SK6-4	3.5-4.0	0.137-0.157"		
SK6-4.5	4.0-4.5	0.157-0.177"		
SK6-5	4.5-5.0	0.177-0.196"		
SK6-5.5	5.0-5.5	0.196-0.216"		
SK6-6	5.5-6.0	0.216-0.236"		
SK6-16S	16 Piece SK6 Collet Set - 0.7mm - 6.0mm			

SK6 Collets - Inch

Part Number	Size
SK6-1/8A	0.125"
SK6-3/16A	0.187"

These inch size collets do not collapse.

SK Collet Drill Chart available on page 229 in the Technical section.



SK6 Collet Rack

Part Number	Description
RACK-ER11/SK6	SK6 collet rack, 24 collets capacity

Accessories:



SK Collets
Page 188



Wrench
Page 193



Back-up screw
Page 194



Coolant-thru and
Slotted Nuts
Page 192

SK10 Collets

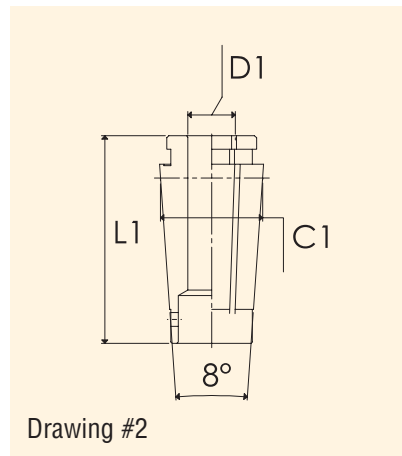
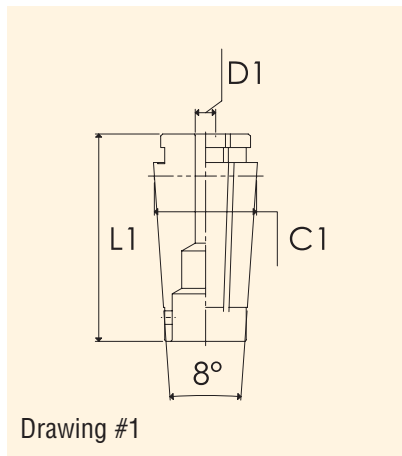

See dimensional data for SK Collets on page 188

SK10 Collets - Metric

Part Number	Collapse Range (mm)	Collapse Range (")	Drawing	
SK10-2	1.75-2.0	0.068-0.078"	#1	
SK10-2.25	2.0-2.25	0.078-0.088"		
SK10-2.5	2.25-2.5	0.088-0.098"		
SK10-2.75	2.5-2.75	0.098-0.108"		
SK10-3	2.75-3.0	0.108-0.118"		
SK10-3.5	3.0-3.5	0.118-0.137"		
SK10-4	3.5-4.0	0.137-0.157"		
SK10-4.5	4.0-4.5	0.157-0.177"		
SK10-5	4.5-5.0	0.177-0.196"		#2
SK10-5.5	5.0-5.5	0.196-0.216"		
SK10-6	5.5-6.0	0.216-0.236"		
SK10-6.5	6.0-6.5	0.236-0.255"		
SK10-7	6.5-7.0	0.255-0.275"		
SK10-7.5	7.0-7.5	0.275-0.295"		
SK10-8	7.5-8.0	0.295-0.314"		
SK10-8.5	8.0-8.5	0.314-0.334"		
SK10-9	8.5-9.0	0.334-0.354"		
SK10-9.5	9.0-9.5	0.354-0.374"		
SK10-10	9.5-10.0	0.374-0.393"		
SK10-19S	19 Piece SK10 Collet Set - 1.75mm - 10.0mm			

SK10 Collets - Inch

Part Number	Size	Drawing
SK10-1/8A	0.125"	#2
SK10-3/16A	0.187"	
SK10-1/4A	0.25"	
SK10-5/16A	0.312"	
SK10-3/8A	0.375"	
SK10-05S	5 piece SK10 Collet Set 1/8 - 3/8" x16th	

These inch size collets do not collapse.

SK Collet Drill Chart available on page 229 in the Technical section.

SK10 Coolant Collets

Part Number	Size	Drawing
SK10-1/4AC	0.25"	#2
SK10-5/16AC	0.312"	
SK10-3/8AC	0.375"	
SK10-6AC	6mm	
SK10-7AC	7mm	
SK10-8AC	8mm	
SK10-9AC	9mm	
SK10-10AC	10mm	

Note: Cutter must be inserted to the full length of the collet.

SK10 Collet Rack

Part Number	Description
RACK-ER16/SK10	SK10 collet rack, 24 collets capacity



Accessories:



SK Collets
Page 188



Wrench
Page 193



Back-up screw
Page 194



Coolant-thru and
Slotted Nuts
Page 192

SK16 Collets

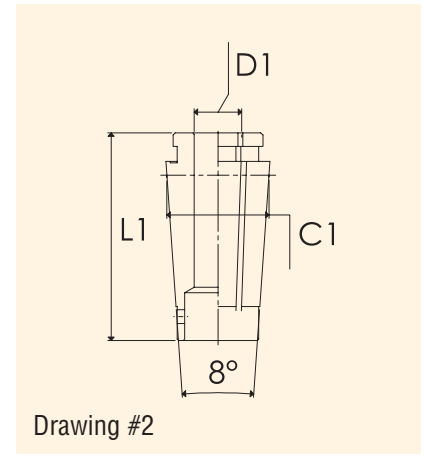
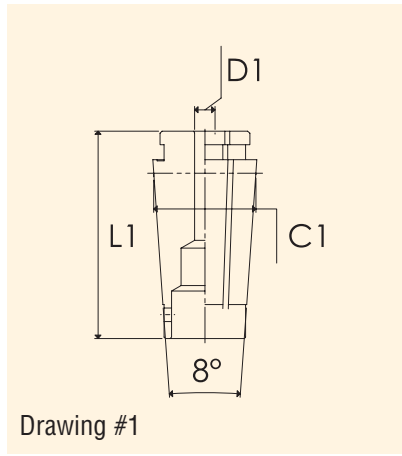

See dimensional data for SK Collets on page 188

SK16 Collets - Metric

Part Number	Collapse Range (mm)	Collapse Range (")	Drawing
SK16-3	2.75-3.0	0.108-0.118"	#1
SK16-3.5	3.0-3.5	0.118-0.137"	
SK16-4	3.5-4.0	0.137-0.157"	
SK16-4.5	4.0-4.5	0.157-0.177"	
SK16-5	4.5-5.0	0.177-0.196"	
SK16-5.5	5.0-5.5	0.196-0.216"	
SK16-6	5.5-6.0	0.216-0.236"	
SK16-6.5	6.0-6.5	0.236-0.255"	
SK16-7	6.5-7.0	0.255-0.275"	
SK16-7.5	7.0-7.5	0.275-0.295"	
SK16-8	7.5-8.0	0.295-0.314"	
SK16-8.5	8.0-8.5	0.314-0.334"	
SK16-9	8.5-9.0	0.334-0.354"	
SK16-9.5	9.0-9.5	0.354-0.374"	
SK16-10	9.5-10.0	0.374-0.393"	
SK16-10.5	10.0-10.5	0.393-0.413"	
SK16-11	10.5-11.0	0.413-0.433"	
SK16-11.5	11.0-11.5	0.433-0.452"	
SK16-12	11.5-12.0	0.452-0.472"	
SK16-12.5	12.0-12.5	0.472-0.492"	
SK16-13	12.5-13.0	0.492-0.511"	
SK16-13.5	13.0-13.5	0.511-0.531"	
SK16-14	13.5-14.0	0.531-0.551"	
SK16-14.5	14.0-14.5	0.551-0.570"	
SK16-15	14.5-15.0	0.570-0.590"	
SK16-15.5	15.0-15.5	0.590-0.610"	
SK16-16	15.5-16.0	0.610-0.629"	

SK16-27S	27 Piece SK16 Collet Set - 2.75mm - 16.0mm
----------	--

SK16 Collets - Inch

Part Number	Size
SK16-1/8A	0.125"
SK16-3/16A	0.187"
SK16-1/4A	0.25"
SK16-5/16A	0.312"
SK16-3/8A	0.375"
SK16-7/16A	0.437"
SK16-1/2A	0.5"
SK16-9/16A	0.562"
SK16-5/8A	0.625"

SK16-09S	9 Piece SK16 Collet Set - 1/8 -5/8" X16th
----------	---

These inch size collets do not collapse.

SK Collet Drill Chart available on page 229 in the Technical section.



SK16 Collet Rack

Part Number	Description
RACK-180DA/SK16/ER25	SK16 collet rack, 30 collets capacity

Accessories:



SK Collets
Page 188



Wrench
Page 193



Back-up screw
Page 194



Coolant-thru and Slotted Nuts
Page 192

SK25 Collets

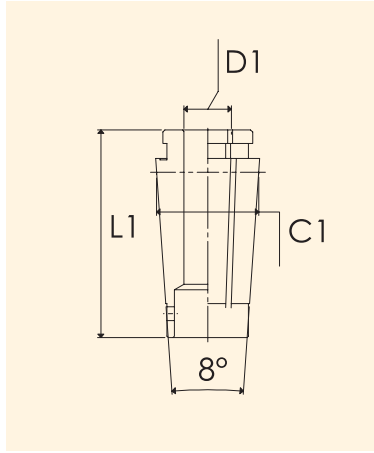

See dimensional data for SK Collets on page 188

SK25 Collets - Metric

Part Number	Collapse Range (mm)	Collapse Range (")
SK25-16.5	16.0-16.5	0.629-0.649"
SK25-17	16.5-17.0	0.649-0.669"
SK25-17.5	17.0-17.5	0.669-0.688"
SK25-18	17.5-18.0	0.688-0.708"
SK25-18.5	18.0-18.5	0.708-0.728"
SK25-19	18.5-19.0	0.728-0.748"
SK25-19.5	19.0-19.5	0.748-0.767"
SK25-20	19.5-20.0	0.767-0.787"
SK25-20.5	20.0-20.5	0.787-0.807"
SK25-21	20.5-21.0	0.807-0.826"
SK25-21.5	21.0-21.5	0.826-0.846"
SK25-22	21.5-22.0	0.846-0.866"
SK25-22.5	22.0-22.5	0.866-0.885"
SK25-23	22.5-23.0	0.885-0.905"
SK25-23.5	23.0-23.5	0.905-0.925"
SK25-24	23.5-24.0	0.925-0.944"
SK25-24.5	24.0-24.5	0.944-0.964"
SK25-25	24.5-25.0	0.964-0.984"
SK25-25.4	25.0-25.4	0.984-0.1000"

SK25-19S	19 Piece SK25 Collet Set - 16.0mm - 25.4mm
----------	--

SK25 Collets - Inch

Part Number	Size
SK25-3/16A	0.187"
SK25-1/4A	0.25"
SK25-5/16A	0.312"
SK25-3/8A	0.375"
SK25-7/16A	0.437"
SK25-1/2A	0.5"
SK25-5/8A	0.625"
SK25-3/4A	0.75"

SK25-08S	8 Piece SK25 Collet Set - 3/16 - 3/4" X16th
----------	---

These inch size collets do not collapse.

SK Collet Drill Chart available on page 229 in the Technical section.

SK25 Collet Rack

Part Number	Description
RACK-5C/100TG/SK25	SK25 collet rack, 30 pieces capacity



Accessories:



SK Collets
Page 188



Wrench
Page 193



Back-up screw
Page 194



Coolant-thru and Slotted Nuts
Page 192

SK Coolant Collet System



Collet Chuck	Collet Series	Coolant Nut Part Number	High-Speed Coolant Nut Part Number	Cutting Tool Size	Coolant-Thru Disk Part Number	Slotted Disk Part Number	Disk Wrench Part Number	Blank Disk (machinable) Part Number
SK6	SK6-range: 0.7-6.0mm [0.027-0.236"]	SKN-6WBJ	SKN-6WBJ(GH)	3mm	SKJ6-3C	SKJ6-3	SKJL-6	SKJ6-BLANK
				4mm	SKJ6-4C	SKJ6-4		
				5mm	SKJ6-5C	SKJ6-5		
				6mm	SKJ6-6C	SKJ6-6		
				1/8"	SKJ6-1/8C	SKJ6-1/8		
				3/16"	SKJ6-3/16C	SKJ6-3/16		
SK10	SK10-range: 1.75-10.0mm [0.068-0.393"]	SKN-10BJ	SKN-10BJ(GH)	3mm	SKJ10-3C	SKJ10-3	SKJL-10	SKJ10-BLANK
				4mm	SKJ10-4C	SKJ10-4		
				5mm	SKJ10-5C	SKJ10-5		
				6mm	SKJ10-6C	SKJ10-6		
				8mm	SKJ10-8C	SKJ10-8		
				10mm	SKJ10-10C	SKJ10-10		
				1/8"	SKJ10-1/8C	SKJ10-1/8		
				3/16"	SKJ10-3/16C	SKJ10-3/16		
				1/4"	SKJ10-1/4C	SKJ10-1/4		
				5/16"	SKJ10-5/16C	SKJ10-5/16		
3/8"	SKJ10-3/8C	SKJ10-3/8						
SK16	SK16-range: 2.75-16.0mm [0.108-0.629"]	SKN-16BJ	SKN-16BJ(GH)	6mm	SKJ16-6C	SKJ16-6	SKJL-16	SKJ16-BLANK
				8mm	SKJ16-8C	SKJ16-8		
				10mm	SKJ16-10C	SKJ16-10		
				12mm	SKJ16-12C	SKJ16-12		
				16mm	SKJ16-16C	SKJ16-16		
				1/4"	SKJ16-1/4C	SKJ16-1/4		
				5/16"	SKJ16-5/16C	SKJ16-5/16		
				3/8"	SKJ16-3/8C	SKJ16-3/8		
				7/16"	SKJ16-7/16C	SKJ16-7/16		
				1/2"	SKJ16-1/2C	SKJ16-1/2		
9/16"	SKJ16-9/16C	SKJ16-9/16						
5/8"	SKJ16-5/8C	SKJ16-5/8						
SK25	SK25-range: 16.0-25.4mm [0.629-0.1000"]	SKN-25BJ	SKN-25BJ(GH)	16mm	SKJ25-16C	SKJ25-16	SKJL-25	SKJ25-BLANK
				20mm	SKJ25-20C	SKJ25-20		
				25mm	SKJ25-25C	SKJ25-25		
				5/8"	SKJ25-5/8C	SKJ25-5/8		
				11/16"	SKJ25-11/16C	SKJ25-11/16		
				3/4"	SKJ25-3/4C	SKJ25-3/4		
				13/16"	SKJ25-13/16C	SKJ25-13/16		
				7/8"	SKJ25-7/8C	SKJ25-7/8		
				15/16"	SKJ25-15/16C	SKJ25-15/16		
1"	SKJ25-1C	SKJ25-1						

Note: Coolant-Thru Disk and Slotted Disk must be ordered on size for the cutting tool.
When using the Coolant Nut, add 6mm (0.236") to the toolholder gage length.
Assembly of the Coolant Nut and Disk is easily accomplished with the Disk Wrench (sold separately).

Accessories

SK Collet Extractor

Part Number	Description
SKR-6	SK6 Collet Extractor
SKR-10	SK10 Collet Extractor
SKR-16	SK16 Collet Extractor
SKR-25	SK25 Collet Extractor



Replacement Nut for SK Collet Chuck

• Standard Style

Part Number	Description
SKN-6WB	Nut for SK6 Collet Chuck
SKN-10B	Nut for SK10 Collet Chuck
SKN-16B	Nut for SK16 Collet Chuck
SKN-25B	Nut for SK25 Collet Chuck



• High-Speed Style

Part Number	Description
SKN-6WB (GH)	Nut for SK6 High-Speed Collet Chuck
SKN-10B (GH)	Nut for SK10 High-Speed Collet Chuck
SKN-16B (GH)	Nut for SK16 High-Speed Collet Chuck
SKN-25B (GH)	Nut for SK25 High-Speed Collet Chuck



Wrench for SK Collet Chuck

Standard Style Part Number	High-Speed Style Part Number	Description
SKL-6W	GH6	Wrench for SK6 Collet Chuck
SKL-10	GH10	Wrench for SK10 Collet Chuck
9HC16	GH16	Wrench for SK16 Collet Chuck
9HC22	GH25	Wrench for SK25 Collet Chuck



Torque Wrench and Attachment for SK Collet Chuck

Part Number	Description
TQW-025	Torque wrench for SK6 Collet Chuck Nut
TQW-150	Torque wrench for SK10/16/25 Collet Chuck Nut
TQW-SK06(18)	SK6 attachment for TQW-025 torque wrench
TQW-SK10(1)	SK10 attachment for TQW-150 torque wrench
TQW-SK16(43)	SK16 attachment for TQW-150 torque wrench
TQW-SK25(60)	SK25 attachment for TQW-150 torque wrench



See the torque wrenches specifications and details on page 222.

Back Up Screws

For Standard SK Collet Chuck

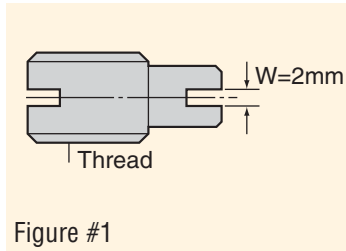

Figure #1

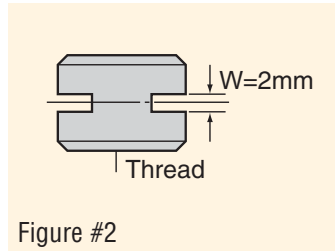

Figure #2

For DIN and Coolant-Thru SK Collet Chuck

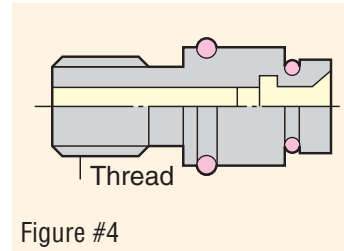

Figure #4

Collet Chuck Type	Part Number	Thread	Figure #
SK6	SKG-8	M8	#1
SK10	SKG-12L	M12	#1
SK16	SKG-18L	M12/M18 P1.5	#1
SK25	SKG-28	M12/M28 P2.0	#1

***Exceptions:**

Collet Chuck Type	Part Number	Thread	Figure #
BT30-SK10-45	SKG-12S	M12	#2
BT30-SK16-90	SKG-12S	M12/M18 P1.5	#2
BT30-SK16-60	SKG-12L	M12/M18 P1.5	#1
BT40-SK16-60	SKG-18S	M12/M18 P1.5	#2
BT30-SK25-90	SKG-12	M12/M28 P2.0	#2
BT40-SK25-75			

Coolant-Thru Back-Up Screw

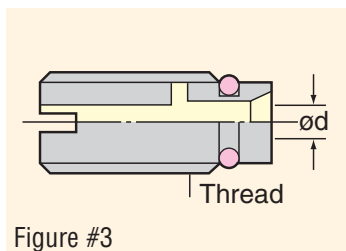

Figure #3

Collet Chuck Type	Part No.	Cutter Shank	d	Thread
SK10	SKG-12HA	4mm	ø2.5mm	M12
	SKG-12H	6mm	ø4mm	
SK16	SKG-18HA	5mm	ø3.5mm	M12/M18 P1.5
	SKG-18H	10mm	ø10mm	
SK25	SKG-28H	16mm	ø12mm	M12/M28 P2.0

***Exceptions:**

Collet Chuck Type	Part No.	Cutter Shank	d	Thread
BT30-SK16-60, -90	SKG-12HA	4mm	ø2.5mm	M12/M18 P1.5
	SKG-12H	6mm	ø4mm	
BT30-SK25-90	SKG-12HA	4mm	ø2.5mm	M12/M28 P2.0
BT40-SK25-75	SKG-12H	6mm	ø4mm	

Collet Chuck Type	Part Number	Cutter Shank	Thread
SK6-...C, ...F	SKG6-6HG	4mm	M8
SK10-...C, ...F	SKG10-10HGA	4mm	M12
	SKG10-10HG	6mm	
SK16-...C, ...F	SKG16-12HGA	5mm	M12/M18 P1.5
	SKG16-12HG	10mm	
SK25-...C, ...F	SKG25-24HG	16mm	M12/M28 P2.0

***Exceptions:**

Collet Chuck Type	Part Number	Cutter Shank	Thread
BT40-SK16F-90	SKG16-12HGBA SKG16-12GB	5mm 10mm	M12/M18 P1.5
HSK50A-SK16C-120 HSK63A-SK16C-120	SKG16-10HGA	5mm	M12/M18 P1.5
HSK100A-SK16C-120			
NC5-46-SK16C-90 NC5-46-SK16C-120	SKG16-10HG	10mm	
BT40-SK25F-120 BT50-SK25F-105	SKG25-24HGA	16mm	M12/M28 P2.0
BT40-SK25F-90	SKG25-18HGC		
BT40-SK25C-90			
NC5-63-SK25C-135 NC5-85-SK25C-135	SKG25-18HGD		
HSK63A-SK25C-135 HSK100A-SK25C-145	SKG25-18HGE		

Note: The back-up screw for the high-speed slim chuck (-P type) is identical for the standard slim chuck.