

BT SK Collet Chucks

- Feature TiN Bearing Nut which considerably improves cutting rigidity and finish
- Narrow body allows access to tight spaces and hard to reach areas
- Unique high-pressure coolant collet system for higher accuracy and gripping torque
- 8° taper SK collet provides twice more clamping force and precision than ER Collet Chucks



TIR: 0.0002" at 4xD



Speed: up to 30,000 rpm



Set-up: quick and easy



Coolant-thru: thru-tool coolant



Drilling
★★★★☆



Milling
★★★★☆



Reaming
★★★★☆

Please note that the maximum RPM listed in our catalog may vary depending on the toolholder shank, weight, balanceability and the G rating.

BT30

Part Number	Collet Size	Wrench	L	L1	H	D	Back-up Screw
BT30-SK6-60	SK6	SKL-6W	2.362"	1.299"	0.827-1.378"	0.768"	SKG-8
BT30-SK6-90	SK6	SKL-6W	3.543"	2.205"	0.827-1.378"	0.768"	SKG-8
BT30-SK10-45	SK10	SKL-10	1.772"	0.866"	1.181-1.969"	1.083"	SKG-12S
BT30-SK10-60	SK10	SKL-10	2.362"	1.378"	1.181-1.969"	1.083"	SKG-12L
BT30-SK10-90	SK10	SKL-10	3.543"	2.559"	1.181-1.969"	1.083"	SKG-12L
BT30-SK16-60	SK16	9HC16	2.362"	1.457"	1.772-2.362"	1.575"	SKG-12L
BT30-SK16-90	SK16	9HC16	3.543"	2.638"	1.772-2.559"	1.575"	SKG-12
BT30-SK25-90	SK25	9HC22	3.543"	2.559"	2.165-2.953"	2.165"	SKG-12

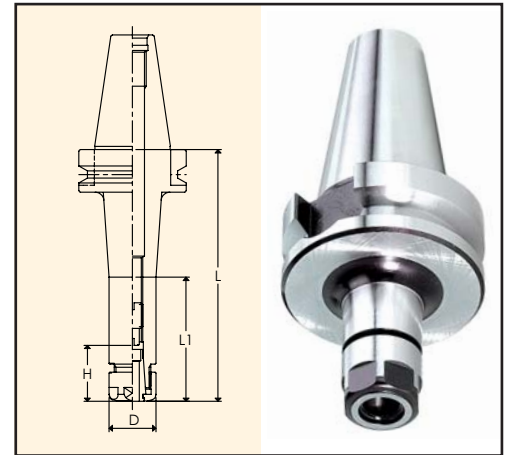

BT40

Part Number	Collet Size	Wrench	L	L1	H	D	Back-up Screw
BT40-SK6-90	SK6	SKL-6W	3.543"	2.008"	0.827-1.378"	0.768"	SKG-8
BT40-SK6-120	SK6	SKL-6W	4.724"	2.362"	0.827-1.378"	0.768"	SKG-8
BT40-SK6-150	SK6	SKL-6W	5.906"	2.362"	0.827-1.378"	0.768"	SKG-8
BT40-SK10-90	SK10	SKL-10	3.543"	1.890"	1.181-1.969"	1.083"	SKG-12L
BT40-SK10-120	SK10	SKL-10	4.724"	2.874"	1.181-1.969"	1.083"	SKG-12L
BT40-SK10-150	SK10	SKL-10	5.906"	2.874"	1.181-1.969"	1.083"	SKG-12L
BT40-SK10-180	SK10	SKL-10	7.086"	-	1.378-1.614"	1.083"	SKG-12L
BT40-SK16-90	SK16	9HC16	3.543"	2.283"	1.772-2.756"	1.575"	SKG-18L
BT40-SK16-120	SK16	9HC16	4.724"	3.465"	1.772-2.756"	1.575"	SKG-18L
BT40-SK16-150	SK16	9HC16	5.906"	4.646"	1.772-2.756"	1.575"	SKG-18L
BT40-SK16-180	SK16	9HC16	7.086"	6.023"	1.654-2.244"	1.575"	SKG-18L
BT40-SK25-75	SK25	9HC22	2.953"	1.850"	2.165-2.953"	2.165"	SKG-12
BT40-SK25-90	SK25	9HC22	3.543"	2.402"	2.165-2.953"	2.165"	SKG-28
BT40-SK25-120	SK25	9HC22	4.724"	3.583"	2.165-3.346"	2.165"	SKG-28

Note: Wrench and back-up screw not included.

Accessories:



SK Collets
Page 188



Wrench
Page 193



Back-up screw
Page 194



Coolant-thru and Slotted Nuts
Page 192