

BT VC Collet Chucks

- Feature TiN Bearing Nut which considerably improves cutting rigidity and finish
- Extra thick body
- High concentricity and repeatability
- Ideal for high-speed applications

Please note that the maximum RPM listed in our catalog may vary depending on the toolholder shank, weight, balanceability and the G rating.



TIR: 0.00012 or better



Speed: up to 40,000 rpm



Set-up: quick and easy to operate



Coolant-thru: thru tool coolant



Drilling
★★★★☆



Milling
★★★★☆



Reaming
★★★★☆

BT30

Part Number	Collet Size	Wrench	L	L1	H	D	D1	Back-up Screw
BT30-VC6-45	VCK6	GH10	1.772"	0.906"	1.38"-1.77"	1.083"	1.083"	VCG6-8A
BT30-VC6-60	VCK6	GH10	2.362"	1.378"	1.38"-1.77"	1.083"	1.248"	VCG6-8A
BT30-VC6-90	VCK6	GH10	3.543"	2.559"	1.38"-1.77"	1.083"	1.315"	VCG6-8A
BT30-VC13-60	VCK13	GH16	2.362"	1.457"	1.97"-2.36"	1.575"	1.618"	VCG13-15A
BT30-VC13-90	VCK13	GH16	3.543"	2.638"	1.97"-2.36"	1.575"	1.626"	VCG13-15A
BT30-VC13-120	VCK13	GH16	4.724"	3.819"	1.97"-2.36"	1.575"	1.669"	VCG13-15A

Note: wrench sold separately.

BT40

Part Number	Collet Size	Wrench	L	L1	H	D	D1	Back-up Screw
BT40-VC6-60	VCK6	GH10	2.362"	1.181"	1.38"-1.77"	1.083"	1.181"	VCG6-8A
BT40-VC6-90	VCK6	GH10	3.543"	2.362"	1.38"-1.77"	1.083"	1.287"	VCG6-8A
BT40-VC6-120	VCK6	GH10	4.724"	3.543"	1.38"-1.77"	1.083"	1.452"	VCG6-8A
BT40-VC13-60	VCK13	GH16	2.362"	1.220"	1.97"-2.36"	1.575"	1.586"	VCG13-15A
BT40-VC13-90	VCK13	GH16	3.543"	2.362"	1.97"-2.36"	1.575"	1.744"	VCG13-15A
BT40-VC13-120	VCK13	GH16	4.724"	3.543"	1.97"-2.36"	1.575"	1.909"	VCG13-15A

Note: wrench sold separately.

BT50

Part Number	Collet Size	Wrench	L	L1	H	D	D1	Back-up Screw
BT50-VC6-105	VCK6	GH10	4.134"	2.441"	1.38"-1.77"	1.083"	1.299"	VCG6-8A
BT50-VC6-135	VCK6	GH10	5.315"	3.622"	1.38"-1.77"	1.083"	1.461"	VCG6-8A
BT50-VC6-165	VCK6	GH10	6.496"	4.803"	1.38"-1.77"	1.083"	1.626"	VCG6-8A
BT50-VC13-105	VCK13	GH16	4.134"	2.441"	1.97"-2.36"	1.575"	1.756"	VCG13-15A
BT50-VC13-135	VCK13	GH16	5.315"	3.622"	1.97"-2.36"	1.575"	1.921"	VCG13-15A
BT50-VC13-165	VCK13	GH16	6.496"	4.803"	1.97"-2.36"	1.575"	1.890"	VCG13-15A

Note: wrench sold separately.

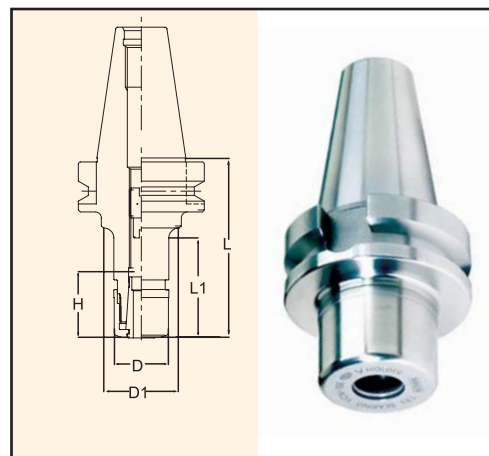

3-Lock VC Collet Chucks for Dual Contact Spindle

3-Lock VC Collet Chucks are available from stock and feature Nikken unique Triple Contact System. Please refer to page 239 in our technical section to learn more about Nikken's revolutionary 3-Lock System and tooling line.

For a complete list of part numbers and pricing, please contact our office at (800) 543-6237



Accessories:



VCK Collets
Page 202



Nut Wrench
Page 204



Back-up screw
Page 204



Coolant-thru nut
Page 204