

CAT Shell Mill Holders

- Accommodates face mills with bore diameters ranging from 1/2" (12mm) to 2" (50mm)
- Pilot diameter sized for precision fit with cutter
- Removable/replaceable drive keys as standard
- Fine thread locking screw included
- AT3 or better taper
- Available in high-speed balanceable versions

Please note that the maximum RPM listed in our catalog may vary depending on the toolholder shank, weight, balanceability and the G rating.



TIR: < .00015 run out at pilot



Milling
★★★★☆



Speed: up to 30,000 rpm



Set-up: quick and easy



Coolant-thru: thru-pilot (optional)

CAT40 - Inch

Part Number	d	L	D	L1	Key Size	Arbor Thread
C4001-0500-1.75	1/2"	1.75"	1.378"	0.57"	1/4"	1/4"-28
C4001-0750-1.75	3/4"	1.75"	1.929"	0.67"	5/16"	3/8"-24
C4011-0750-4.00	3/4"	4.00"	1.929"	0.67"	5/16"	3/8"-24
C4001-1000-1.75	1"	1.75"	2.382"	0.67"	3/8"	1/2"-20
C4011-1000-4.00	1"	4.00"	2.382"	0.67"	3/8"	1/2"-20
C4001-1250-2.00	1-1/4"	2.00"	2.882"	0.67"	1/2"	5/8"-18
C4011-1250-4.00	1-1/4"	4.00"	2.882"	0.67"	1/2"	5/8"-18
C4001-1500-2.00	1-1/2"	2.00"	3.799"	0.93"	5/8"	3/4"-16
C4011-1500-4.00	1-1/2"	4.00"	3.799"	0.93"	5/8"	3/4"-16

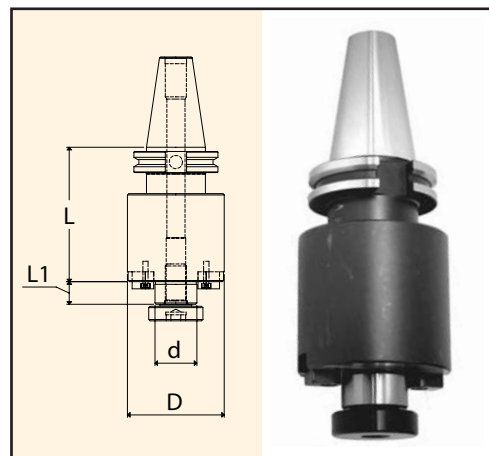

CAT50 - Inch

Part Number	d	L	D	L1	Key Size	Arbor Thread
C5001-0750-1.75	3/4"	1.75"	1.929"	0.67"	5/16"	3/8"-24
C5011-0750-4.00	3/4"	4.00"	1.929"	0.67"	5/16"	3/8"-24
C5021-0750-6.00	3/4"	6.00"	1.929"	0.67"	5/16"	3/8"-24
C5031-0750-8.00	3/4"	8.00"	1.929"	0.67"	5/16"	3/8"-24
C5001-1000-1.75	1"	1.75"	2.382"	0.69"	3/8"	1/2"-20
C5011-1000-4.00	1"	4.00"	2.382"	0.69"	3/8"	1/2"-20
C5021-1000-6.00	1"	6.00"	2.382"	0.69"	3/8"	1/2"-20
C5031-1000-8.00	1"	8.00"	2.382"	0.69"	3/8"	1/2"-20
C5001-1250-1.75	1-1/4"	1.75"	2.882"	0.69"	1/2"	5/8"-18
C5011-1250-4.00	1-1/4"	4.00"	2.882"	0.69"	1/2"	5/8"-18
C5021-1250-6.00	1-1/4"	6.00"	2.882"	0.69"	1/2"	5/8"-18
C5031-1250-8.00	1-1/4"	8.00"	2.882"	0.69"	1/2"	5/8"-18
C5001-1500-2.00	1-1/2"	2.00"	3.799"	0.93"	5/8"	3/4"-1
C5011-1500-4.00	1-1/2"	4.00"	3.799"	0.93"	5/8"	3/4"-16
C5021-1500-6.00	1-1/2"	6.00"	3.799"	0.93"	5/8"	3/4"-16
C5031-1500-8.00	1-1/2"	8.00"	3.799"	0.93"	5/8"	3/4"-16
C5001-2000-2.00	2"	2.00"	4.382"	0.93"	3/4"	1"-14
C5011-2000-4.00	2"	4.00"	4.382"	0.93"	3/4"	1"-14
C5021-2000-6.00	2"	6.00"	4.382"	0.93"	3/4"	1"-14

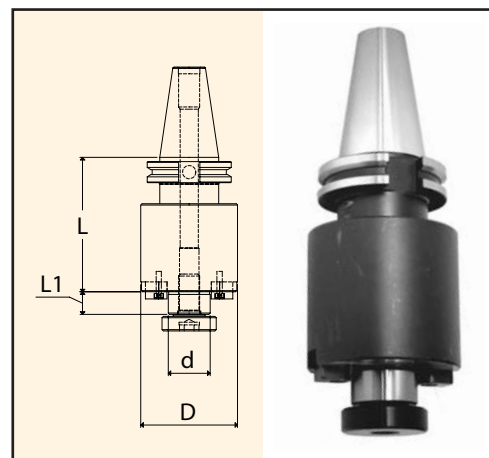

Accessories:



Replacement Keys
Page 83



Replacement Arbor Screws
Page 83

Note: All shell mill holders are coolant-thru. Arbor screws are not coolant-thru but can be modified to facilitate coolant capabilities: see cutter manufacturer for modification requirement.