

CAT Shell Mill Holders

CAT40 - Metric

Part Number	d	L	D	L1	Key Size	Arbor Thread
C4001-22-50	22mm	50mm	40mm	19mm	10mm	M10
C4001-27-50	27mm	50mm	48mm	21mm	12mm	M12
C4001-32-50	32mm	50mm	58mm	24mm	14mm	M16
C4001-40-60	40mm	60mm	67mm	27mm	16mm	M20

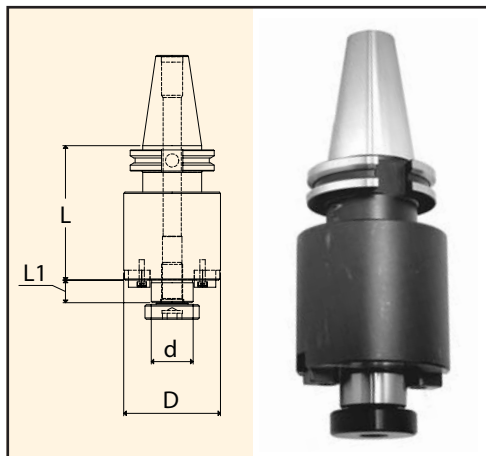

CAT50 - Metric

Part Number	d	L	D	L1	Key Size	Arbor Thread
C5001-22-60	22mm	60mm	40mm	19mm	10mm	M10
C5001-27-60	27mm	60mm	48mm	21mm	12mm	M12
C5001-32-60	32mm	60mm	58mm	24mm	14mm	M16
C5001-40-60	40mm	60mm	67mm	27mm	16mm	M20

CAT50 Face Mill Holders

Part Number	d	L	D	L1	Key size
C50F1-2000-2.95	2"	2.95"	5.06"	0.86"	3/4"
C50F1-2500-2.95	2-1/2"	2.95"	5.00"	1.18"	1.00"

Note: Face Mill Holders are supplied with four 5/8-11 mounting bolts. Pitch circle diameter is 4".

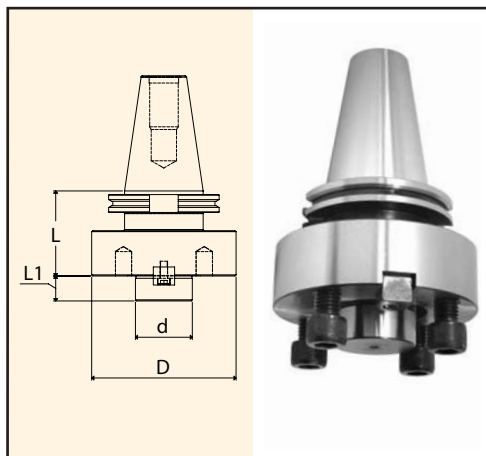

Accessories:



Replacement Keys
Page 83



Replacement Arbor Screws
Page 83

Note: All shell mill holders are coolant-thru. Arbor screws are not coolant-thru but can be modified to facilitate coolant capabilities: see cutter manufacturer for modification requirement.