

CAT and BT Jacobs Taper Holders

CAT40/50

Part Number	Taper	JT Size	L	D
C4003-0002-1.61	CT40	JT#2	1.61"	.560"
C4003-0003-1.58	CT40	JT#3	1.58"	.812"
C4003-0004-1.49	CT40	JT#4	1.49"	1.13"
C4003-0006-1.61	CT40	JT#6	1.61"	.677"
C4003-0033-1.61	CT40	JT#33	1.61"	.625"
C5003-0002-1.61	CT50	JT#2	1.61"	.560"
C5003-0003-1.58	CT50	JT#3	1.58"	.812"
C5003-0004-1.49	CT50	JT#4	1.49"	1.13"
C5003-0006-1.61	CT50	JT#6	1.61"	.677"
C5003-0033-1.61	CT50	JT#33	1.61"	.625"

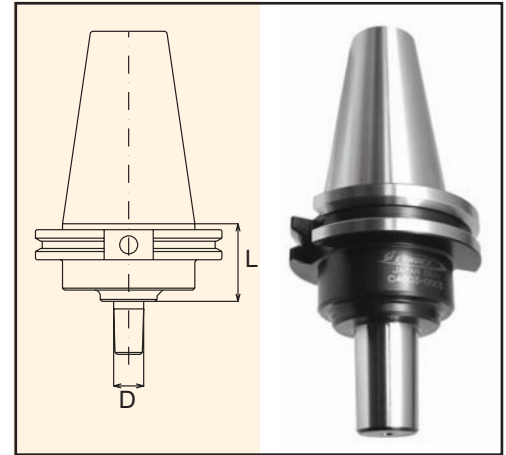

BT30/40/50

Part Number	Taper	JT Size	L	D
B3003-0001-1.06	BT30	JT#1	1.06"	.385"
B3003-0002-1.02	BT30	JT#2	1.02"	.560"
B3003-0003-0.98	BT30	JT#3	0.98"	.812"
B3003-0006-1.02	BT30	JT#6	1.02"	.677"
B3003-0033-1.02	BT30	JT#33	1.02"	.625"
B4003-0002-1.61	BT40	JT#2	1.61"	.560"
B4003-0003-1.57	BT40	JT#3	1.57"	.812"
B4003-0006-1.61	BT40	JT#6	1.61"	.677"
B4003-0033-1.61	BT40	JT#33	1.61"	.625"
B5003-0002-1.61	BT50	JT#2	1.61"	.560"
B5003-0003-1.57	BT50	JT#3	1.57"	.812"
B5003-0004-1.49	BT50	JT#4	1.49"	1.13"
B5003-0006-1.61	BT50	JT#6	1.61"	.677"
B5003-0033-1.61	BT50	JT#33	1.61"	.625"

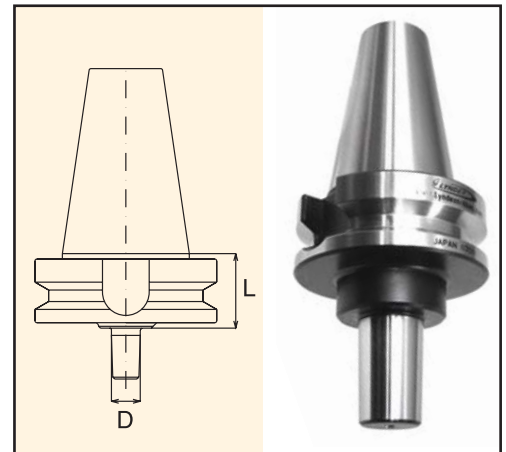

Accessories:



Jacobs Brand Drill Chuck
Page 92



Replacement Key
Page 92