

CAT and BT Morse Taper Holders

- Balanced to 12,000RPM
- Coolant-thru capable



TIR: minimal



Speed: up to 12,000 rpm



Set-up: quick and easy



Coolant-thru: available



Drilling

★★★★★



Reaming

★★★★★

Please note that the maximum RPM listed in our catalog may vary depending on the toolholder shank, weight, balanceability and the G rating.

CAT 40/50

Part Number	Taper	Size	L	D	D1
C4004-0001-1.75	CT40	MT#1	1.75"	.475"	1.00"
C4004-0002-2.36	CT40	MT#2	2.36"	.700"	1.25"
C4004-0003-3.00	CT40	MT#3	3.00"	.938"	1.57"
C4004-0004-3.54	CT40	MT#4	3.54"	1.23"	1.97"
C5004-0002-1.75	CT50	MT#2	1.75"	.700"	1.25"
C5004-0003-1.75	CT50	MT#3	1.75"	.938"	1.57"
C5004-0004-3.00	CT50	MT#4	3.00"	1.23"	1.97"
C5004-0005-4.13	CT50	MT#5	4.13"	1.75"	2.75"

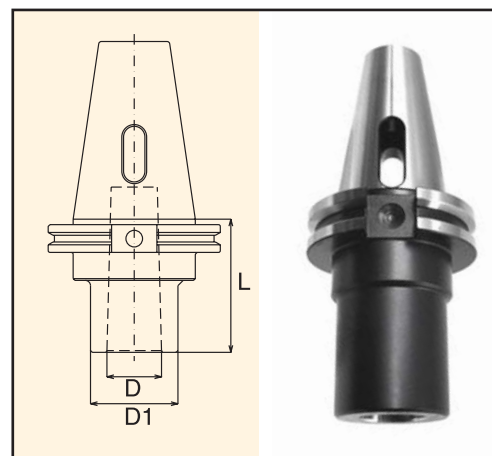

BT 30/40/50

Part Number	Taper	Size	L	D	D1
B3004-0001-1.75	BT30	MT#1	1.75"	.475"	1.00"
B3004-0002-2.36	BT30	MT#2	2.36"	.700"	1.25"
B4004-0001-1.75	BT40	MT#1	1.75"	.475"	1.00"
B4004-0002-2.36	BT40	MT#2	2.36"	.700"	1.25"
B4004-0003-3.00	BT40	MT#3	3.00"	.938"	1.57"
B4004-0004-3.54	BT40	MT#4	3.54"	1.23"	1.97"
B5004-0002-1.75	BT50	MT#2	1.75"	.700"	1.25"
B5004-0003-1.75	BT50	MT#3	1.75"	.938"	1.57"
B5004-0004-3.00	BT50	MT#4	3.00"	1.23"	1.97"
B5004-0005-4.13	BT50	MT#5	4.13"	1.75"	2.75"

