

CAT TG Collet Chucks

- Ground surface for perpendicular contact between retention knob and holder
- AT3 or better taper
- Equipped with a left-hand-threaded stop screw and chuck nut
- Available in high-speed balanceable versions

Please note that the maximum RPM listed in our catalog may vary depending on the toolholder shank, weight, balanceability and the G rating.



TIR: < .0002 at collet face



Speed: up to 20,000 rpm



Set-up: quick and easy



Coolant-thru: thru-tool coolant



Drilling
★★★★☆



Milling
★★★★☆



Reaming
★★★★☆

CAT40

Part Number	Style	Collet Series	Collet Range	Nut Wrench	L	L1	D
C4007-0250-2.25	Standard	25TG	3/64-1/4"	25TG-HEX	2.25"	0.61"	0.75"
C4017-0250-4.00	Standard	25TG	3/64-1/4"	25TG-HEX	4.00"	0.61"	0.75"
C4007-0500-2.50	Standard	50TG	1/8-1/2"	50TG-SPAN	2.50"	1.30"	1.34"
C4017-0500-4.00	Standard	50TG	1/8-1/2"	50TG-SPAN	4.00"	1.30"	1.34"
C40S7-0750-2.50	Stubby	75TG	3/64-3/4"	75TG-SPAN	2.50"	1.61"	1.89"
C4007-0750-3.00	Standard	75TG	3/64-3/4"	75TG-SPAN	3.00"	1.61"	1.89"
C4017-0750-5.00	Standard	75TG	3/64-3/4"	75TG-SPAN	5.00"	1.61"	1.89"
C40S7-1000-2.75	Stubby	100TG	3/64-1"	100TG-SPAN	2.75"	2.13"	2.50"
C4007-1000-3.50	Standard	100TG	3/64-1"	100TG-SPAN	3.50"	2.13"	2.50"
C4017-1000-5.50	Standard	100TG	3/64-1"	100TG-SPAN	5.50"	2.13"	2.50"
C4007-1500-6.00	Standard	150TG	1/2-1-1/2"	150TG-SPAN	6.00"	2.88"	3.50"

TG Collet Chucks come with back-up screw.

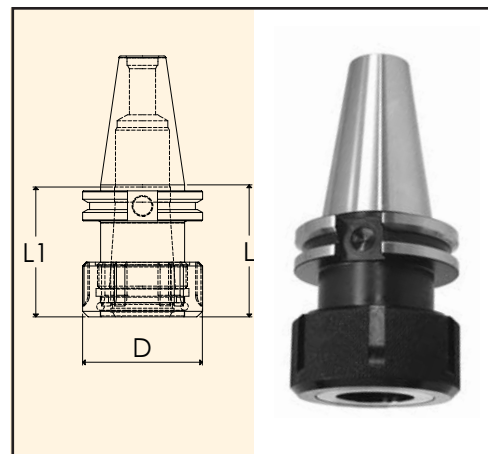

Stubby

CAT50

Part Number	Style	Collet Series	Collet Range	Nut Wrench	L	L1	D
C5007-0500-2.50	Standard	50TG	1/8-1/2"	50TG-SPAN	2.50"	1.30"	1.34"
C5017-0500-4.00	Standard	50TG	1/8-1/2"	50TG-SPAN	4.00"	1.30"	1.34"
C5007-0750-3.50	Standard	75TG	3/64-3/4"	75TG-SPAN	3.50"	1.61"	1.89"
C5017-0750-5.50	Standard	75TG	3/64-3/4"	75TG-SPAN	5.50"	1.61"	1.89"
C5007-1000-3.50	Standard	100TG	3/64-1"	100TG-SPAN	3.50"	2.13"	2.50"
C5017-1000-5.50	Standard	100TG	3/64-1"	100TG-SPAN	5.50"	2.13"	2.50"
C5027-1000-7.50	Standard	100TG	3/64-1"	100TG-SPAN	7.50"	2.13"	2.50"
C5037-1000-10.00	Standard	100TG	3/64-1"	100TG-SPAN	10.00"	2.13"	3.50"
C5007-1500-3.50	Standard	150TG	1/2-1-1/2"	150TG-SPAN	3.50"	2.88"	3.50"
C5017-1500-6.00	Standard	150TG	1/2-1-1/2"	150TG-SPAN	6.00"	2.88"	3.50"

TG Collet Chucks come with back-up screw.

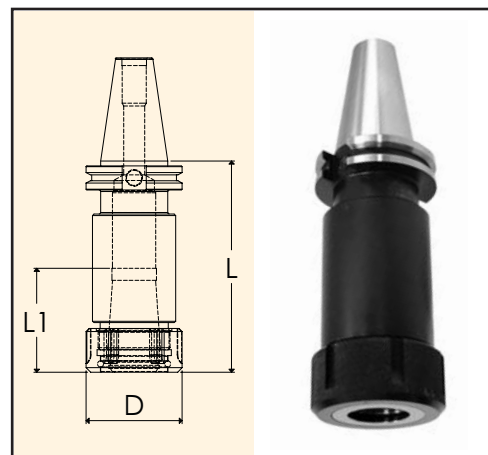

Standard

To use: first insert the collet into the chuck nut by squeezing the collet and pressing its face into the chuck nut's retaining ring until the collet's collar is fully seated. Then load the assembly into the chuck, insert a cutting tool, and tighten with the appropriate nut wrench to the recommended tightening torque.

To remove: simply squeeze the collet while pulling it from the chuck nut at an angle. Our handy 100TG or 150TG Collet Squeezers ease the removal of these larger collets.



When removing the back-up screw, TG Collet Chucks have coolant-thru capabilities. No disc, special nut or wrench required!
See TG Coolant Collets on pages 62-64.

Accessories:



TG Collets
Pages 61-65



TG Torque Wrench
Page 66



TG Back Up Screw
Page 66



TG Nut
Page 66