

Milling Chucks

Shrink Fit Holders

SK Collet Chucks

VC Collet Chucks

MMC Collet Chucks

Accessories



Current Promotion

Scan
these
QR Codes



Featured Video

TOOLJAW® — The Toolholder Clamp Champ



Lyndex-Nikken ToolJaws are machinists' favorite tooling setup fixtures because they are so handy and practical. Load a toolholder into a ToolJaw. You'll gain immediate access to both the working end and the taper end and your toolholder will be secured by a vise-tight grip.

Easy to use, just place or mount your ToolJaw in a convenient spot and slip a holder into its cradle. Raise the flange lock and secure it with an easy-to-grip thumb screw.

ToolJaw provides maximum toolholder accessibility with minimum handling. Less handling means fewer chances of costly toolholders being dropped or damaged. Save the time and the hassles of using yesterday's toolholder loading and unloading techniques, and save the money you would spend on replacing damaged toolholders.

Features

- Access both ends of your toolholders simultaneously.
- Minimize toolholder handling.
- Speed up your setup.
- Proven performance in the world's top shops.
- Convenient and practical.
- Easy to use.

TOOLJAW® CLAMPS

REPLACEMENT KEYS

REPLACEMENT JAWS

Description	Part Number	Part Number	Part Number
BT30 Taper TOOLJAW	B30-TOOLJAW	B30-KEY	B30-JAW
BT35 Taper TOOLJAW	B35-TOOLJAW	B35-KEY	B35-JAW
BT40 Taper TOOLJAW	B40-TOOLJAW	B40-KEY	B40-JAW
BT45 Taper TOOLJAW	B45-TOOLJAW	B45-KEY	B45-JAW
BT50 Taper TOOLJAW	B50-TOOLJAW	B50-KEY	B50-JAW
CT30 Taper TOOLJAW	C30-TOOLJAW	C30-KEY	C30-JAW
CT40 Taper TOOLJAW	C40-TOOLJAW	C40-KEY	C40-JAW
CT45 Taper TOOLJAW	C45-TOOLJAW	C45-KEY	C45-JAW
CT50 Taper TOOLJAW	C50-TOOLJAW	C50-KEY	C50-JAW
HSK40A TOOLJAW	HSK40A-TOOLJAW	HSK40A-KEY	HSK40A-JAW
HSK63A TOOLJAW	HSK63A-TOOLJAW	HSK63A-KEY	HSK63A-JAW
HSK100A TOOLJAW	HSK100A-TOOLJAW	HSK100A-KEY	HSK100A-JAW

Nikken Tool Clamper, Tightening Fixtures and ATC Alignment Kit

Nikken Tool clamper is designed for symmetrical holders without drive key slots or U-groove. By changing the clamper head to the suitable size, the same base can be used for the other taper sizes.

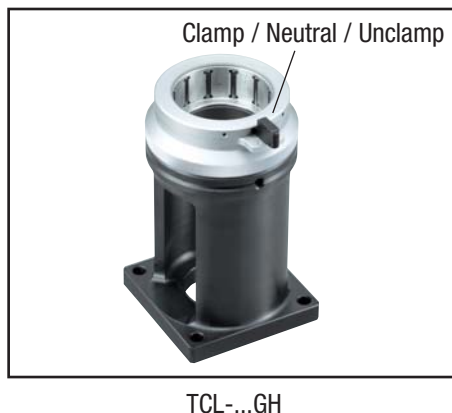

NIKKEN TOOL CLAMPER FOR HSK TOOLING

Taper	Tool Clamper Complete Unit	Base Part Number	Head Part Number
HSK32E	TCL-32GH	TCL-BD	TCL-32HD
HSK40A, 40E	TCL-40GH		TCL-40HD
HSK50A, 50E	TCL-50GH		TCL-50HD
HSK63A, 63E, 63F	TCL-63GH		TCL-63HD
HSK100A	TCL-100GH		TCL-100HD

TIGHTENING FIXTURES

Part Number	Taper	Length	Diameter
30-LCFX	30	3.54"	2.17"
35-LCFX	35	3.61"	2.36"
40-LCFX	40	4.27"	2.76"
45-LCFX	45	5.31"	2.95"
50-LCFX	50	6.20"	3.94"



ATC ALIGNMENT KIT

The Automatic Tool Changer (ATC) allows for service on your machine to check alignment of the ATC arm with the spindle and magazine. One taper adapter can be used with multiple flange adapters. For example: the 40 taper adapter can accommodate both CT40 and BT40 flange adapters.

Part Number	Taper
ATC-ALIGN-#40	#40
ATC-ALIGN-#50	#50
ATC-ALIGN-HSK63A	HSK63A
ATC-ALIGN-HSK100A	HSK100A



The ATC Alignment Kit consists of :

- a taper adapter
- a flange adapter
- a bushing
- a centering pin

PointFinder™

**Locate the precise relative positioning of the workpiece to the spindle
– measuring directly from the spindle itself.**

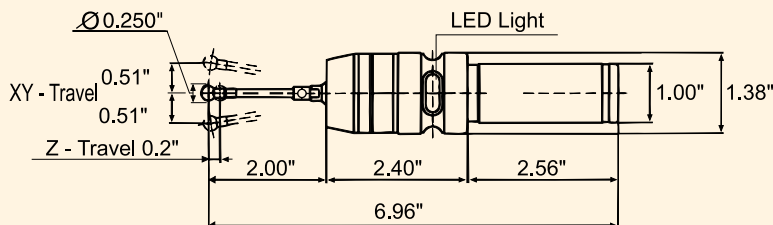

• **Advanced conductive detection system**

- Instant LED response
- Direct action—no relays
- Works with all metals
- Unaffected by cutting oil

• **Precise**

- Position detection accuracy: +/- 0.0008"
- Stylus recovery accuracy: +/- 0.00004"
- Stylus to shank concentricity: +/- 0.0008"

• **Overrun protected**

- X-axis and Y-axis: 0.400"
- Z-axis: 0.200"

• **Versatile design**

- Convenient 1" straight shank configuration
- Projects 4.40" from holder when fully loaded

• **Hardened, precision ground steel construction**

PointFinder™ is an all-in-one replacement for primary axis setters, calipers, and depth and centering gauges. Not only is it quick and easy to use, its accuracy is beyond compare.

Simply load it into a toolholder and mount it into the machine's spindle. Gauge length pre-setting is unnecessary for X- or Y-axis coordinate determination. Move PointFinder slowly along either the X- or Y-axis toward the workpiece. Its bright LED flashes at the exact point where its 1/4" diameter probe touches the workpiece's surface. That point is exactly 1/8" away from spindle center. Z-axis coordinate determination requires pre-setting, and the point of probe contact marks the exact Z-axis coordinate.

With the workpiece locked into position, your other measurements are performed with the same ease and speed.

Features

- Position your workpiece without primary axis setters.
- Measure without calipers.
- Set depths, find centers without gauges.
- Fast, easy and accurate.
- Turn expensive setup time into profit-making production time.

Part Number	Description
PF-2	PointFinder with a 2" Stylus
PF-Stylus-2	Replacement Stylus for PointFinder PF-2

XYZSetter™ and ZeroSetter™

XYZSETTER™

Easy, accurate setting of any axis.

XYZSetters minimize your setup time to maximize your production time. These unique instruments allow you to precisely establish all primary references quickly and dependably. Two models are available for either front or side reading. Both models are precision made of ground, hardened tool steel. Both have dial indicators graduated in thousandths (0.001”).

Part Number	Description
XYZ-A	Front Reading XYZSetter™
XYZ-B	Side Reading XYZSetter™

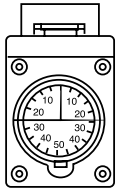

Zero the dial with the master cap held in place.

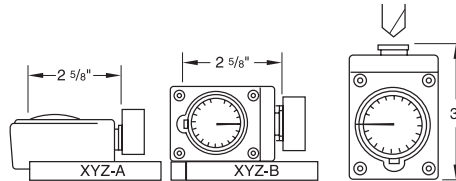

Remove the master cap and position the XYZSetter™ on your workpiece. Adjust your spindle until the cutter (or a test bar) touches the unit's measuring face. Your absolute reference point is established when the unit's dial rests at zero.

ZeroSetter™

Quick, simple, precise Z-axis off setting.

ZeroSetter assures fast reliable results every time you off-set your Z-axis. Your setup time will be reduced, so you'll gain valuable production time. Made of hardened tool steel, each setter is meticulously ground for top precision. ZeroSetter establishes an absolute gauge length of 4" or 6" that serves as your primary reference point. Its dial indicator is graduated in thousandths (0.001”).

Part Number	Description
ZERO-SET4	4" Gauge Length ZeroSetter
HP-4	4" Gauge Length Height Presetter
HP-6	6" Gauge Length Height Presetter



HP-4

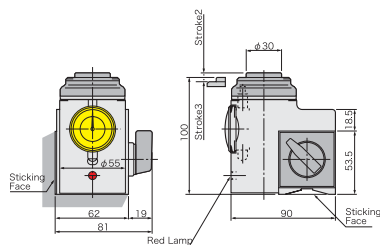

HP-6

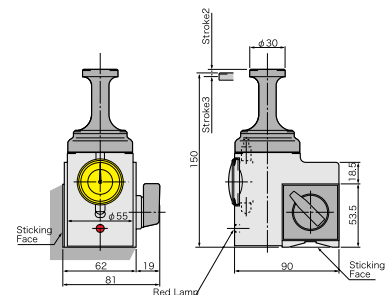

Spindle Wipes



Spindle Wipes

These handy wipers quick-clean your spindles, assuring that your toolholder tapers make continuous positive contact with them for repeatable on-center performance. They're also perfect for cleaning the bores of your collet chucks and Morse Taper holders.

FOR MACHINE SPINDLES

Part Number	Description
W30	30-Taper Spindle Clean equipped with cleaning blades
30-ST	W30 Standard cleaning blade set
30-VR	W30 Varnish removing blade set
30-EP	W30 Polishing blade set
W35	35-Taper Spindle Clean equipped with cleaning blades
35-ST	W35 Standard cleaning blade set
35-VR	W35 Varnish removing blade set
35-EP	W35 Polishing blade set
W40	40-Taper Spindle Clean equipped with cleaning blades
40-ST	W40 Standard cleaning blade set
40-VR	W40 Varnish removing blade set
40-EP	W40 Polishing blade set
W45	45-Taper Spindle Clean equipped with cleaning blades
45-ST	W45 Standard cleaning blade set
45-VR	W45 Varnish removing blade set
45-EP	W45 Polishing blade set
W50	50-Taper Spindle Clean equipped with cleaning blades
50-ST	W50 Standard cleaning blade set
50-VR	W50 Varnish removing blade set
50-EP	W50 Polishing blade set

For Morse Taper, R8 Taper, TG and ER Collet Chuck Spindles Clean, please contact us directly at 800-543-6237.

Test Bars

- Precision ground
- Maximum T.I.R. of 0.0002"
- Excellent for gauging spindle runout

BT30/40/50

Part Number	Taper	L	D
B30-TESTBAR-8.0	BT30	8.00"	1.50"
B40-TESTBAR-14.0	BT40	14.00"	2.00"
B50-TESTBAR-14.0	BT50	14.00"	2.00"

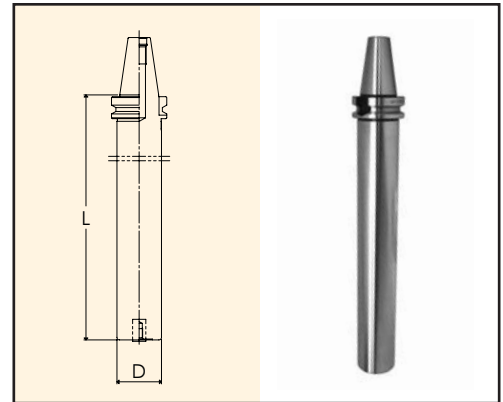

CAT40/50

Part Number	Taper	L	D
C40-TESTBAR-14.0	CT40	14.00"	2.00"
C50-TESTBAR-14.0	CT50	14.00"	2.00"

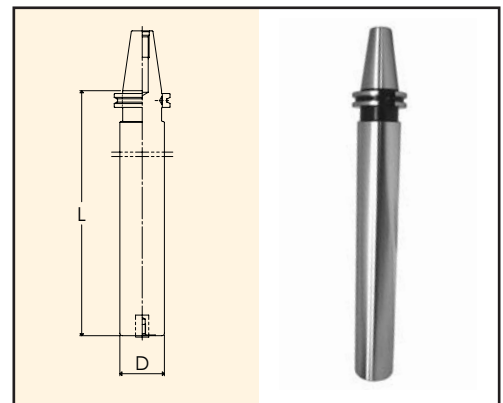

HSK63A/100A

Part Number	Taper	L	D
HSK63A-TESTBAR-14.0	HSK63A	14.00"	2.00"
HSK100A-TESTBAR-14.0	HSK100A	14.00"	2.00"

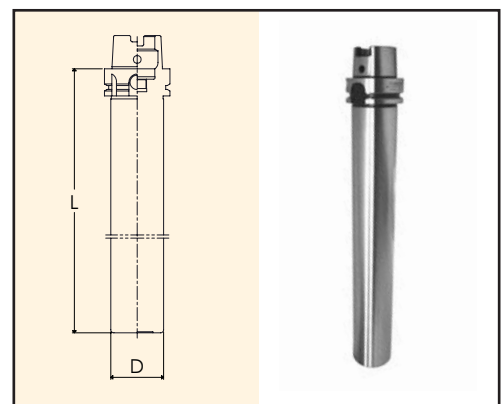

Momimem Carbide Indexable Chamfering & Center-Drilling Tools

Achieve super long life and ultra fast cutting performance.

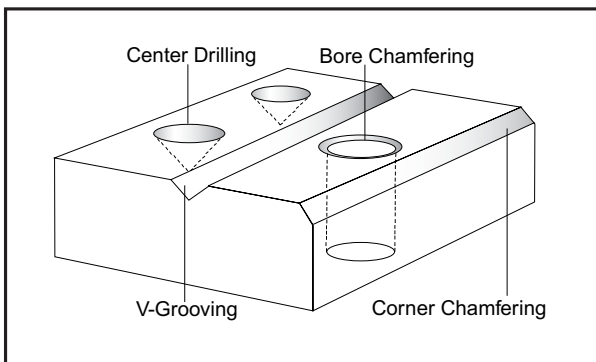

Features

- Our new CNC multi-purpose tool's patented inserts are specifically designed to eliminate the problems of chipping at the center point associated with conventional center drills.
- Our unique toolholding system assures high accuracy and saves time when replacing inserts.
- Our single blade system eliminates cutting vibration.
- Momimem is durable (even for high speed cutting) which greatly improves productivity.
- Momimem enables centering and chamfering work to be done on the same center.

Applications

- Center Drilling
 - Corner Chamfering
 - Bore Chamfering
 - V-Groove Cutting
- Tough, accurate, economical and excellent performance.

Multi-Purpose Functions

- Spot Drilling (Center Drilling)
- Countersink and Chamfering (Plunging)
- Spiral Cutting (Milling)
- "V" Grooving (Milling)

Momimem Carbide Indexable Chamfering & Center-Drilling Tools

Indexable carbide tools for chamfering, center-drilling and v-grooving with one tool.

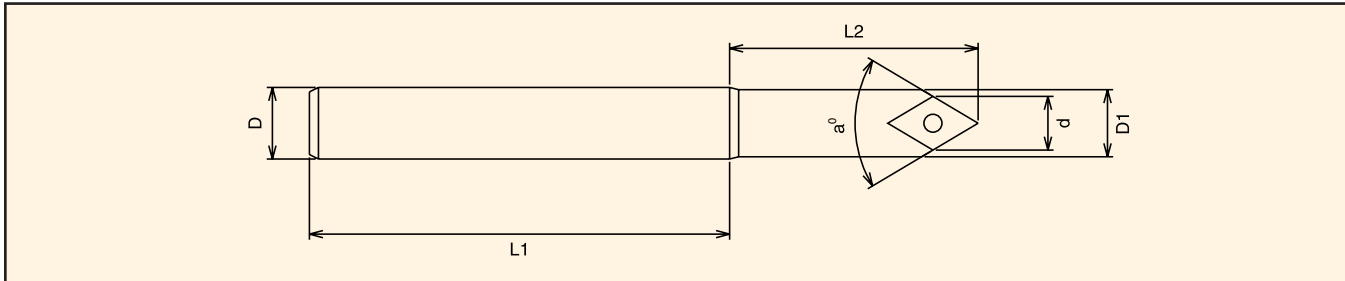

Momimem Chamfer/Center Drill

Part Number	L1	L2	D	d	a°	D1
SC1630C	3.27"	1.23"	5/8"	.625"	118°	.650"
SC1645C	3.35"	1.15"	5/8"	.500"	90°	.551"
SC1660D	3.75"	2.05"	5/8"	.472"	60°	.472"

Note: radius for SC1660D, SC1645C and SC1630C is 0.4, 0.6 and 0.6 respectively.

Insert

Part Number	Grade	Application
C32GUX-NK1010	NK1010	Aluminum Cast Iron (Momimen 1630 and 1645)
C32GUX-NK2020	NK2020	Steels (Momimen 1630 and 1645)
D43GUX-NK1010	NK1010	Aluminum Cast Iron (Momimen 1660)
D43GUX-NK5050	NK5050	Steels (Momimen 1660)

Note: insert package quantity: 12 pieces.

Recommended Speeds & Feeds

Material	For Center drilling & V-Grooving			For Chamfer Milling (down cut)		
	RPM	IPM	Grade	RPM	IPM	Grade
Mild Steels	3000	3.2	NK2020	3000	8	NK2020
Stainless	2000	2	NK2020	2500	6	NK2020
Die Steels	3000	2	NK2020	3000	6	NK2020
Cast Iron	3200	8	NK1010	3000	8	NK1010
Aluminum	4000	6	NK1010	4000	12	NK1010

Chibimomi - CNC Multi-Purpose Center Drill and Chamfering Tools

Achieve super long life and ultra fast cutting performance.

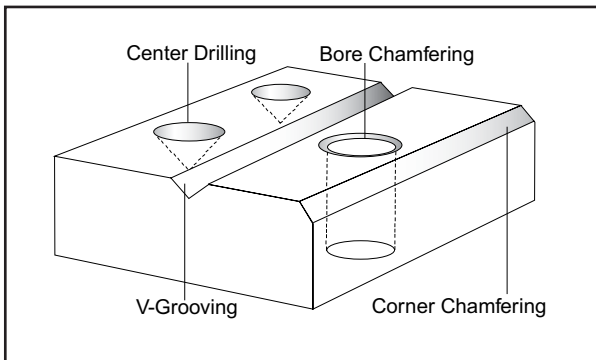

Features

- 3/8" shank and 5/16" lip assure highly accurate machining in narrow and limited space points.
- Our originally designed patented insert eliminates cutting vibration and cracking.
- Our originally designed patented insert assures problem-free secondary deburring.
- Save time when replacing inserts because no tool compensation is needed.
- Number of toolholders in the ATC can be reduced because this can be used for spot drilling, countersinking and chamfering, bore chamfering, edge chamfering, and v-grooving.
- Greatly improves productivity due to high-speed cutting.

Applications

- Center Drilling
- Corner Chamfering
- Bore Chamfering
- V-groove Cutting

Tough, accurate, economical and excellent performance.

Multi-Purpose Functions

- Spot Drilling (Center Drilling)
- Countersink and Chamfering (Plunging)
- Spiral Cutting (Milling)
- "V" Grooving (Milling)

Chibimomi - Carbide Indexable Chamfering & Center-Drilling Tools

Indexable carbide tools for chamfering, center-drilling and v-grooving with one tool.

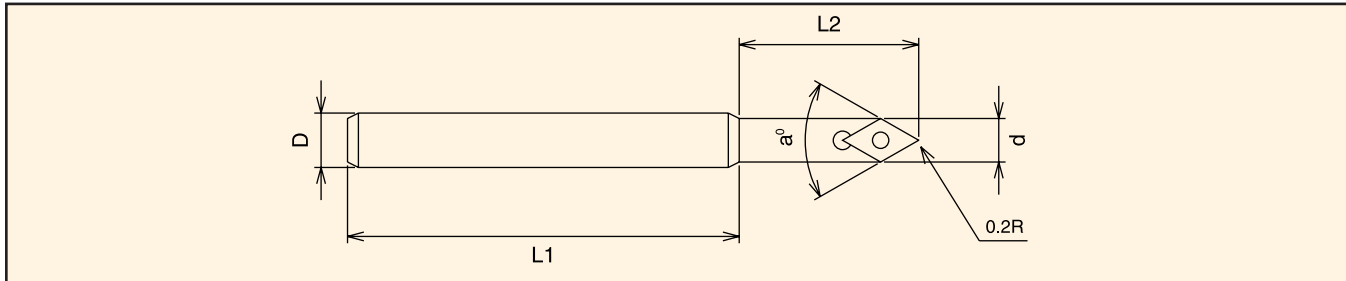

Chibimomi Chamfer/Center Drill

Part Number	L1	L2	D	d	a°
SCM1045C	2.68"	1.37"	3/8"	.315"	90°
SCM1045CL	5.14"	1.37"	3/8"	.315"	90°

Insert

Part Number	Grade	Application
C22GUX-NK1010	NK1010	Aluminum, Cast Iron
C22GUX-NK5050	NK5050	Steels

Recommended Speeds & Feeds

Material	For Center drilling & V-Grooving			For Chamfer Milling (down cut)		
	RPM	IPM	Grade	RPM	IPM	Grade
Mild Steels	3000	2	NK5050	3500	19	NK5050
Stainless	2800	2	NK5050	3000	13	NK5050
Aluminum	4000	4	NK1010	5000	39	NK1010

TQW Torque Wrench



The TQW Torque Wrench is very accurate and easy-to-use, guaranteeing maximum accuracy and preventing tool overtightening or breakage.

- Variable torque adjustable wrench
- Robust and durable
- Ergonomic grip
- Easy to read inch and metric scale
- Strong steel shaft is highly corrosion resistant
- Easy to set up and operation:
 - A. Set wrench to desired torque setting
 - B. Insert attachment
 - C. Torque down on collet nut until it clicks in place

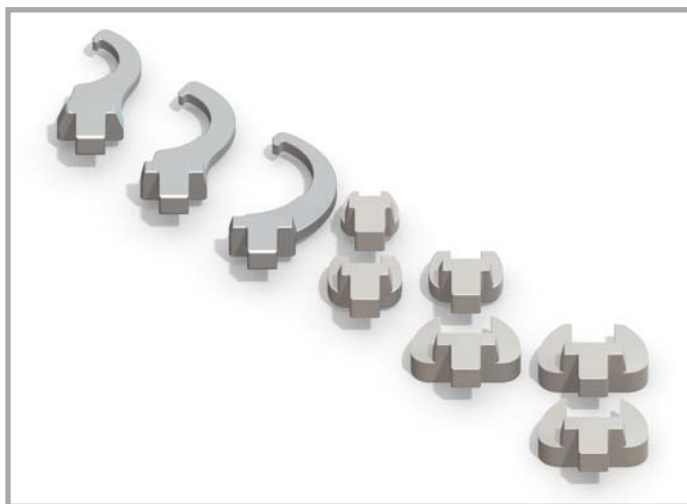

A wide selection of attachments are available: ER, SK, TG, Pull Stud, Milling Chuck, Capto

Design and Construction



A "Push-Button Locking Device" securely locks the preset torque and prevents inadvertent adjustment.



Handle is shaped to provide a firm and ergonomic grip.

Collet Number	Part Number	Attachments (Type and Size)			Torque Range		Torque Wrench	
		Description	mm	inch	lbs	Nm	Part Number	Description
ER8	TQW-ER08	Blank	Special Attachment - Call		4	6	TQW-025	14X18, 25ft.lbs
ER11	TQW-ER11(17)	Hex/OE	17	0.67	11	15		
ER16	TQW-ER16(32)	Hook	32 [+/-5mm]	1.25	40	54	TQW-150	14X18, 150ft.lbs
ER20	TQW-ER20(32)		32 [+/-5mm]	1.25	60	81		
ER25	TQW-ER25(43)		43 [+/-5mm]	1.69	75	102		
ER32	TQW-ER32(50)		50 [+/-5mm]	1.96	100	136		
ER40	TQW-ER40(63)		63 [+/-5mm]	2.48	125	169		
SK6	TQW-SK06(18)	Hex/OE	18	0.71	14	19	TQW-025	14X18, 25ft.lbs
SK10	TQW-SK10(1)		25.4	1.00	33-34	45-46		
SK16	TQW-SK16(43)	Hook	43 [+/-5mm]	1.69	55-62	74-84	TQW-150	14X18, 150ft.lbs
SK25	TQW-SK25(60)		60 [+/-5mm]	2.36	66-73	90-99		
TG75	TQW-TG075(50)	Hook	50 [+/-5mm]	1.96	55	75	TQW-150	14X18, 150ft.lbs
TG100	TQW-TG100(63)		63 [+/-5mm]	2.48	75	102		
TG150	TQW-TG150(82)		82 [+/-5mm]	3.22	100	136		
Pull-Stud-13mm	TQW-PS(13)	Hex/OE	13	0.51	14 ~ 18	19 to 25	TQW-025	14X18, 25ft.lbs
Pull-Stud-3/4 (19mm)	TQW-PS(19)		19	0.75	44 ~ 59	60 to 80	TQW-150	14X18, 150ft.lbs
Pull-Stud-30mm	TQW-PS(30)		30	1.18	147 ~ 185	200 to 250		
Pull-Stud-1.1/4	TQW-PS(32)		31.75	1/1/2004	147 ~ 185	200 to 250		
Milling Chuck 3/4"	TQW-C3/4(50)	Hook	50 [+/-5mm]	1.96	19 to 24	26-32	TQW-150	14X18, 150ft.lbs
Milling Chuck 1"	TQW-C1(60)		60 [+/-5mm]	2.36	27 to 31	36-42		
Milling Chuck 1.1/4"	TQW-C1/4(72)		72 [+/-5mm]	2.83	48 to 59	65-80		
Capto C3	TQW-CAPTO3(8)	Hex	8	0.31	26	35	TQW-150	14X18, 150ft.lbs
Capto C4	TQW-CAPTO4(10)		10	0.39	37	50		
Capto C5	TQW-CAPTO5(12)		12	0.47	52	70		