

CAT End Mill Holders

CAT 50 - Inch (cont.)

Part Number	Style	d	L	L1	L2	D	D1	Set Screw Part Number
C50S6-1250-2.00	Stubby	1-1/4"	2.00"	2.55"	-	2.75"	-	S3/4-16X11/16
C5006-1250-4.00	Standard	1-1/4"	4.00"	2.55"	-	2.48"	-	S3/4-16X11/16 (2)
C5016-1250-6.00	Standard	1-1/4"	6.00"	2.55"	-	2.48"	-	S3/4-16X11/16 (2)
C5026-1250-8.00	Ext. Length	1-1/4"	8.00"	2.76"	3.87"	2.48"	2.75"	S3/4-16X11/16 (2)
C5066-1250-15.00	Ext. Length	1-1/4"	15.00"	2.76"	10.87"	2.48"	2.75"	S3/4-16X11/16 (2)
C50S6-1500-2.25	Stubby	1-1/2"	2.25"	2.83"	-	2.75"	-	S3/4-16X11/16
C5006-1500-4.50	Standard	1-1/2"	4.50"	2.83"	-	2.99"	-	S3/4-16X11/16 (2)
C5016-1500-7.00	Standard	1-1/2"	7.00"	2.83"	-	2.99"	-	S3/4-16X11/16 (2)
C5026-1500-9.00	Standard	1-1/2"	9.00"	2.83"	-	2.99"	-	S3/4-16X11/16 (2)
C50S6-2000-3.63	Stubby	2"	3.63"	3.34"	-	3.74"	-	S1"-14X7/8 (1) S1"-17X7/16 (1)
C5026-2000-10.00	Standard	2"	10.00"	3.34"	-	3.74"	-	S1"-14X7/8 (2)
C5006-2000-5.37	Standard	2"	5.37"	3.34"	-	3.74"	-	S1"-14X7/8 (2)
C5016-2000-8.00	Standard	2"	8.00"	3.34"	-	3.74"	-	S1"-14X7/8 (2)
C5006-2500-6.00	Standard	2-1/2"	6.00"	3.66"	-	4.25"	-	S1"-14X7/8 (2)

Set Screws are included. Back-up screws not included.
Extended length End Mill Holders can be modified to DIN standard.

CAT 50 - Metric

Part Number	Style	d	L	L1	D	Set Screw Part Number
C5006-6-2.50	Standard	6mm	2.50"	1.10"	0.79"	S1/4-28X1/4
C5006-8-2.50	Standard	8mm	2.50"	1.10"	0.87"	S5/16-24X1/4
C5006-10-2.50	Standard	10mm	2.50"	1.26"	1.00"	S3/8-24X5/16
C5006-12-2.63	Standard	12mm	2.63"	1.50"	1.38"	S7/16-20X3/8
C5006-14-3.00	Standard	14mm	3.00"	1.61"	1.65"	S9/16-18X1/2
C5006-16-3.00	Standard	16mm	3.00"	1.61"	1.65"	S9/16-18X1/2
C5006-18-3.00	Standard	18mm	3.00"	1.77"	1.89"	S5/8-18X1/2
C5006-20-3.00	Standard	20mm	3.00"	1.77"	1.89"	S5/8-18X1/2
C5006-25-4.00	Standard	25mm	4.00"	2.36"	2.36"	S3/4-16X11/16 (2)
C5006-32-4.00	Standard	32mm	4.00"	2.55"	2.48"	S3/4-16X11/16 (2)
C5006-40-4.50	Standard	40mm	4.50"	2.95"	3.07"	S3/4-16X11/16 (2)
C5006-42-4.50	Standard	42mm	4.50"	2.83"	3.07"	S3/4-16X11/16 (2)
C5006-50-5.37	Standard	50mm	5.37"	3.35"	3.74"	S1"-14X7/8 (2)

Set Screws are included. Back-up screws not included.

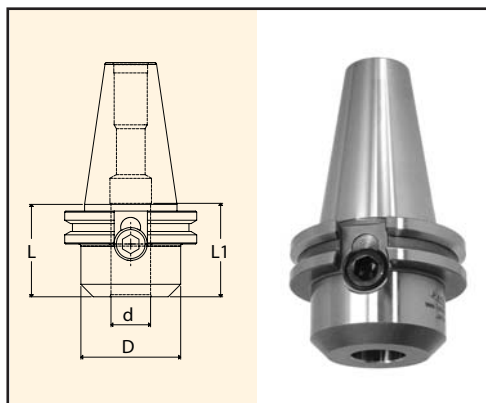

Stubby

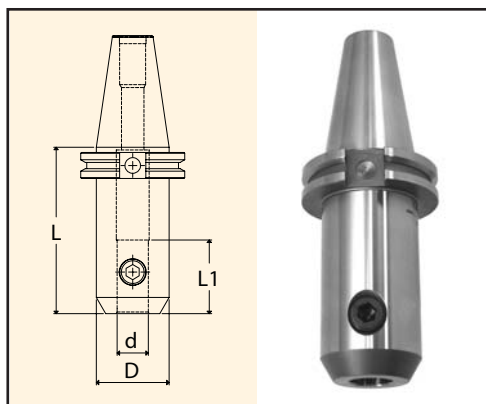

Standard

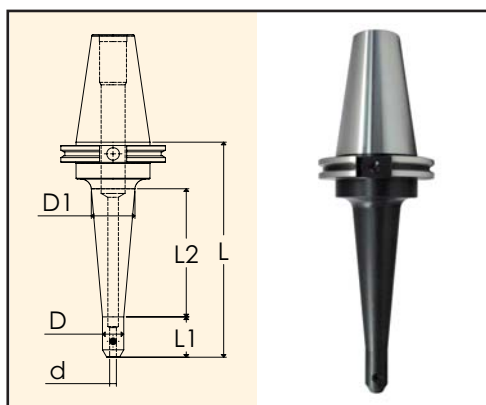

Extended Length

Accessories:



Set Screws
Page 28



Set Screws for Aerospace Holders
Page 28



Tool Jaw
Page 212



Pull Stud
Pages 139-140